



iJRASET

International Journal For Research in
Applied Science and Engineering Technology



INTERNATIONAL JOURNAL FOR RESEARCH

IN APPLIED SCIENCE & ENGINEERING TECHNOLOGY

Volume: 8

Issue: III

Month of publication: March 2020

DOI:

www.ijraset.com

Call:  08813907089

E-mail ID: ijraset@gmail.com

Auto Secure: A Device with Emotion Detection Enabled Automation and Telegram App for Home Safety

Prof. R. B. Rathod¹, Rachana S. Bhagwat², Alka R. Nimje³, Muskan U. Shaikh⁴, Megh V. Shirke⁵

^{1, 2, 3, 4, 5}Computer Department, Savitribai Phule Pune University

Abstract: *Advancement in IOT based application has become the state-of-the art automation among the researcher due to the availability of Internet everywhere ,so more and more progress is taking place in IOT . To make the application more advisable, web based and android based technologies have gained their importance in this cutting edge technology. In this paper, we are studing a device with emotion detection enable automation using telegram app user can manage their home security in an easy manner. This system is very useful for reducing the cost of monitoring the movement from apperence. In this paper, we are showing a real time recognition system is proposed which will manage images very fast. The main aim of this paper is to protect home, office by recognizing people. The proposed system is real-time, fast and has low computational cost.*

Keywords: *Raspberry Pi, Face recognition, Emotion Detection, IOT, Machine Learning, LBP, Haar Cascade*

I. INTRODUCTION

Computer vision can present more security system in the IoT podium for smart houses. It has capability to recognize a person in the incorrect area and at the wrong time because this person may be a malicious one for the environment. It has an combination of large applications in the ranges: public security, access control, credit card verification, criminal identification, law enforcement commerce, information security, human computer intelligent interaction, and digital libraries. The face is the most important part of human's body. So, it can reflect many emotions of a person. Long year ago, humans were using the non-living things like smart cards, plastic cards, PINS, tokens and keys for authentication, and to get grant access in restricted areas like ISRO, NASA and DRDO. The system will fall into two class; face detection and face recognition[1]. Facial recognition is a way of perceiving a human face through technology. A facial recognition system used to map facial features from a photograph or video. It compares the information with a database of faces. Facial recognition can help to authenticate unique identity of human face. Using face detection, we can get the information we need to perform tasks like amplify selfies and portraits. There are a few methods for fetching the most important features to implement face recognition. HAAR-CASCADE , and Local Binary Patterns (LBP) along with feature extraction techniques and are used for classification of emotion for the said automation system. To get fast discriminatory performance and good results, these techniques are chosen for face recognition. OpenCV is the most widely used library for computer vision. It uses machine learning algorithms to check for faces within a picture. Patterns and features that must be matched. The algorithms break the task of identifying the face into smaller, bite-sized tasks, each of which is easy to solve. These tasks are also called classifiers. In this paper, Raspberry Pi 3B+ is utilized and Raspberry Pi camera is connected to it. The system will take an image when ultrasonic sensor detects any movement. Then, computer vision is enforced to the captured images. Subsequently, the system address the images to a smartphone via the Internet.

II. LITERATURE REVIEW

With the increase in issues related to security and safety, the home automation and smart home devices are gaining lots of appreciation. Nowadays a door is not just a wooden piece or wooden block that can be opened or closed manually to enter or exit, but in the current generation a door is technically a medium to let only genuine users to let enter the home and keeps intruders away from home and don't let them enter[3]. This paper proposes a method for detecting human emotions by taking into record for facial analysis. The emotions can meticulously be determined by analysing features by covering a wide range of emotions. Principal Component Analysis (PCA), Linear Discriminant Analysis (LDA), and Local Binary Patterns Histograms (LBPH) along with feature extraction techniques and are used for classification of emotion for the said automation system.

A smart door is also known as Intelligent door which works on the support of digital code, passwords, scanning and recognizing factors such as fingerprint scan, eye scan or retina scan[3]. A smart door not just opens or shuts when user commands but also keeps record of its surrounding environment. These can be further classified into passive and active mode. The active procedure emanates

infrared signal from the controller and catches the reflected signal to decide whether there is any object near the door. High cost has made this method less prominent. With the exponential growth of IoT devices, IoT security is enhancing important. Smart Door Lock System is excessively important because it is closely related to the safety of the user. The data sent and received of existing Smart Door Lock system is accessible to forgery and hacking. To improve these security issues, a Smart Door Lock system based on blockchain. This administers data integrity and non-repudiation.

The idea is to automate the home appliances according to the user requirements without human interaction. User will not be in a home of taking out its mobile phone and clicking the buttons for controlling home appliances. Several methods have been introduced in the design of such systems using sensors, biometrics and face detection[4].

III. PROPOSED METHODOLOGY

A. System Architecture

This system uses Raspberry Pi 3B+ as the microcontroller. When a person comes at the door he has to enter the password on the 4X4 Matrix Keypad. The password will be displayed as **** on 12C 16X2 LCD display. If the password entered is right then he/she will be granted access. If the password entered wrong no access will be granted. If access is granted the door will be opened using a servo motor as shown in Fig.1.

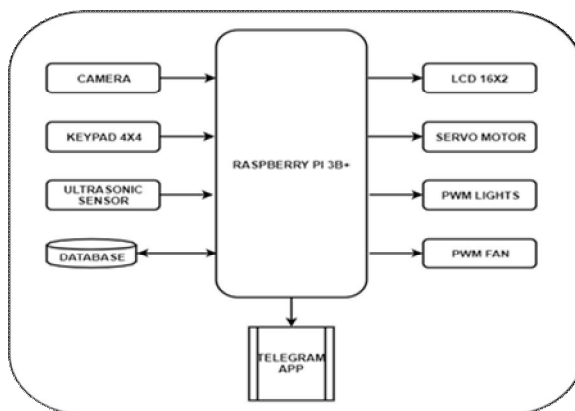

Fig .1 Flowcharts for face recognition system

Only when the person goes inside the door will be closed. This will be monitored by an ultrasonic sensor. If no person enters even after access granted then after fixed interval the door will be closed automatically. Along with this an image is captured by the raspberry Pi Camera in both situations (access granted / access not granted) and is sent to Telegram App. If the password entered is correct then the image captured will be processed for mood detection. Then accordingly the light and fan will be automatically controlled. For example, if the mood of a person is angry then the fans will be operated at full speed and the light will be switched on in such a way that it will produce a clam color.

B. Working Modules

There are three main module in propose system. Face recognition module which will endeavor with openCV, as soon as a person will arrive they need to put password on the door to get it open .The password will be of two nature 1) Master keys 2) Slave keys.Master key will be with permanent family members and Slave key will be generated by owner if any guest arrive while owner is not at home, it will work like one time password .after putting the right password the person will get entry in the house. Before generating the slave key the master will also get the snap of the human standing in front of door to be sure if there is no intrusion happening there with the help of openCV and Telegram app. Children safety module which will notify parents if they are not home and there child arrive by then .Emotion detection module is about emotion detection which will also work with openCV, it will detect the face of human in front of camera and detect his mood while getting in so it will help to keep humans mood better by managing appliances like lights and fan.Now-a-days there is a common trend for a human- computers interaction in the area of machine intelligence. Real time detection of face and illustrate different facial expressions as happy, anger, sad, fear etc. is based on facial features and their actions. The key elements of face are contemplated for detection of face and prediction of expressions or emotions of face. To determine the various facial expressions, the variations in each facial feature are used. For detection and classification of different types of facial expressions, machine learning algorithms are used by training of different set of images. The expected algorithm uses open source computer vision (OpenCV) and Machine learning with python.

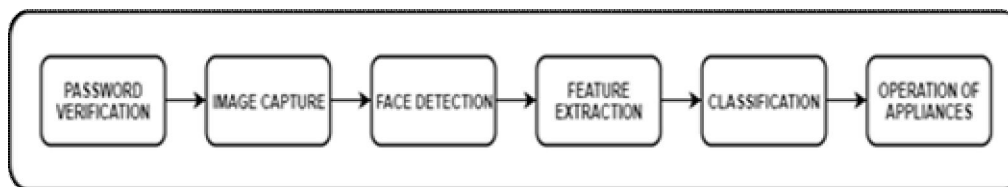

Fig.2.Steps for recognizing images

C. Algorithms

1) *Face detection using Haar Cascades:* A Haar Cascade is based on “Haar Wavelets” which is defines as: An arrangement of rescaled “square- shaped” functions which together form a wavelet family or basis as shown in Fig.3. It is based on the Haar Wavelet approach to analyze pixels in the image into squares by function. This uses machine learning techniques to get a high degree of efficiency from what is called “training data”. This uses “integral image” concepts to compute the “features” notice. It is then worn to detect objects in other images. Initially, the algorithm uses a lot of positive images (images of faces) and negative images (images without faces) to train the classifier. Then we need to extract features from that image. Features are nothing but numerical information derives from the images that can be used to differentiate one image from another.

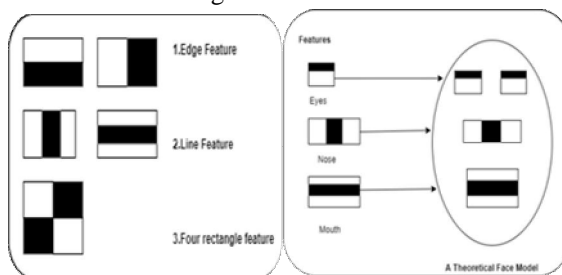

Fig.3.Feature extraction in Haar Cascade

2) *Local Binary Pattern(LBP):* Local Binary Pattern (LBP) is a easy still very capable balance operator which classify the pixels of an picture by thresholds the area of each pixel and considers the conclusion as a binary number. It accept facilitate been determined that when LBP is joined with histograms of oriented gradients (HOG) descriptor, it improves the detection performance considerably on some data sheets. Using the LBP connected with histograms we can represent the face images with a simple data vector as shown in Fig.4.

The LBPH uses 4 parameters:

- a) *Radius:* the radius is used to construct the circular local binary pattern and represents the radius around the central pixel. It is normally set to 1.
- b) *Neighbour's:* the number of sample points to frame the circular local binary pattern. Keep in mind: the more sample points you joined, the higher the computational cost. It is normally set to 8.
- c) *Grid X:* the number of cells in the horizontal control. The more cells, the finer the grid, the higher the dimensionality of the resulting feature vector. It is normally set to 8.
- d) *Grid Y:* the number of cells in the vertical direction. The more cells, the finer the framework, the higher the dimensionality of the output feature vector. It is usually set to 8.



Fig.4. LBP feature extraction steps

e) *Training the Algorithm:* Before everything , we need to train the algorithm. To do so, we need to use a dataset with the facial images of the people we want to observe. We need to also set an identity (it may be a number or the name of the person) for each image, so the algorithm will use this data to observe an input image and give you an output. Images of the same person must have the same identity. With the training set already build, let’s see the LBPH computational steps. Implementing the LBP operation: The first computational step of the LBPH is to create an average image that clarify the original image in a better way, by highlighting the facial characteristics. To do so, the algorithm uses a concept of a sliding window, based on the parameters radius and neighbour’s.

Suppose we have a facial image in grayscale. We can get part of this image as a square of 3x3 pixels. It can also be represented as a 3x3 matrix containing the intensity of each pixel (0~255).Then, we need to take the central value of the matrix to be used as the threshold. This value will be used to fix the new values from the 8 neighbors. For each neighbour of the central value, we set a new binary number. We set 1 for values equal or higher than the threshold and 0 for values lower than the threshold. Now, the matrix will contain only binary number.We need to concatenate each binary value from each position from the matrix line by line into a new binary value (e.g. 10001101).Then, we convert this binary value to a decimal value and set it to the central value of the matrix, which is actually a pixel from the original image. At the end of this action (LBP procedure), we have a new image which represents better the characteristics of the original image.

D. *Structural outline*

As shown in Fig.5. the device gets on first of all then checks for the images and start detecting emotion . Then it will ask for Passkey , if the passkey enter by user it right then sends photo and with the help of signals, which where got generate before when emotion where got detected light color get selected to light up the room and speed of the fan gets controlled. Else if the Passkey was entered wrong then photo gets send and again goes to check the certain image in dataset.

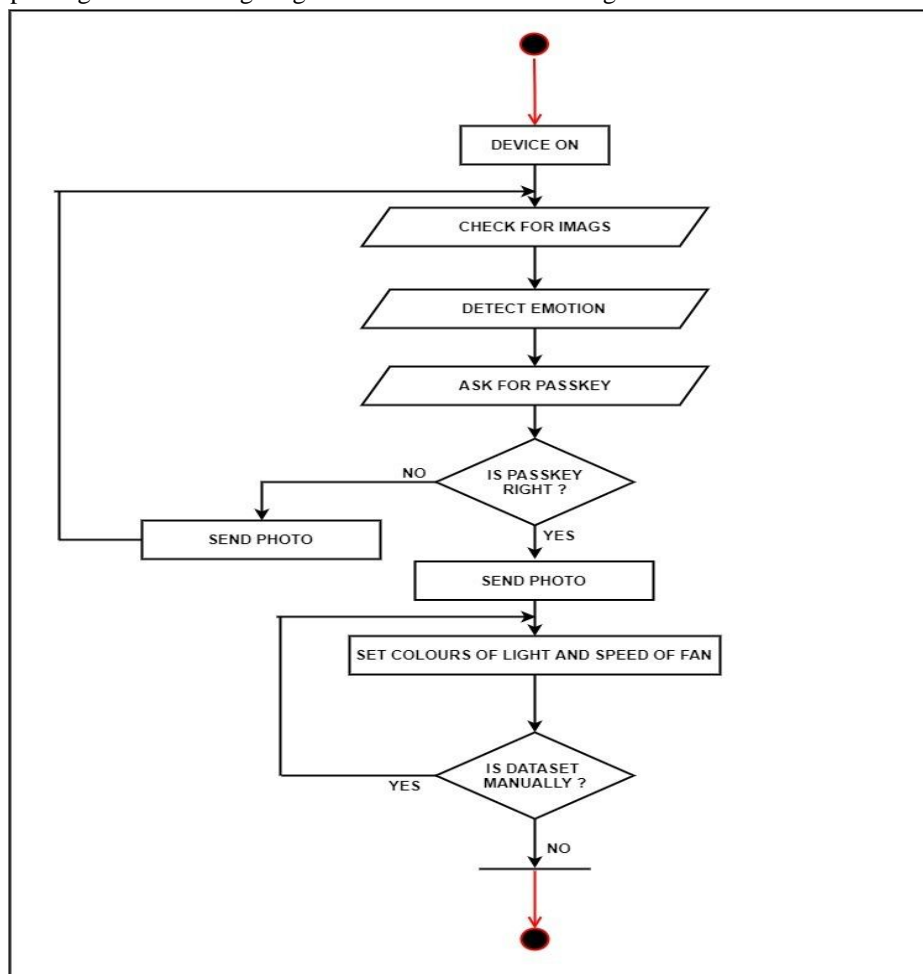

Fig .5 Flowcharts for face recognition system

IV. EXPERIMENTAL SETUP

The system will be able to profitably identify the faces in the collection of images. The algorithm will be applied to all the images. The real-time face detection will be done by means of Haar-Cascade and real-time face recognition is done by recognition algorithm are more justifiable for real-time means of local binary pattern (LBP). The face detection and because they uses less CPU resource and low costs



Fig.6. Experimental setup

The system will be trigger when a motion is detected. At the same time, the camera click the events. The notifications and the images will be sent to a smartphone app “Telegram” as shown in Fig. 6. Raspberry Pi 3+ has a Wi-Fi wireless technology. This will be useful to view activity and show images instantly on the smartphone gadgets. The acknowledged output images and notifications on the smartphone are shown in Fig.6. The algorithm recognizes and detects human faces successfully for known faces that collected in the database .If unknown face/person enters the room, the system will notify unknown person is coming to the room as come out in .

V. CONCLUSIONS

A possible solution is expected to utilize computer vision in the IOT in this paper. Smartphone is the main benefit of this paper which is appropriate by the client to obtain notifications with the captured images. This system helps to enhance and automate the aid of industries, cities, homes and towns. A dual step security will also be implemented with the help of passkey implementation algorithm with facial recognition. The results show that the proposed face recognition system can be used in a real time environment. Thus, main objective of this work is to make our home automation system more secure and intelligent.

REFERENCES

- [1] Yong Tae, Park Pranesh, Sthapit Jae “Smart Digital Door Lock for the Home Automation” Department of Information and Communication Engineering, Chosun University Gwangju, South Korea (2018).
- [2] Donhee Han, Hongjin Kim, Juwook Jang” Blockchain based Smart Door Lock system” International Department of Electronic Engineering 2018
- [3] FAIZ AMAN, ANITHA C “Motion Sensing and Image Capturing based Smart Door System on Android Platform” International Conference on Energy, Communication, Data Analytics and Soft Computing (ICECDS-2017), The National Institute of Engineering Mysuru, INDIA
- [4] Sunder Ali Khawaja, Kamran Dahri, Muhammad Aslam Kumbhar, Altaf Mazhar Soomro,”Facial Expression Recognition using two-tier classification and its Application to Smart Home Automation System” IEEE, Institute of Information and Communication Technology, 2018
- [5] Dacheng Peng and Chen Peng“ A design and implement for simple smart home system for consumers”2016 28th Chinese Control and Decision Conference (CCDC)
- [6] Burak Sarp, Tolga Karalar “Real Time Smart Door System for Home Security” International Journal of Scientific Research in Information Systems and Engineering (IJSRISE) Volume 1, Issue 2, December-2015.



10.22214/IJRASET



45.98



IMPACT FACTOR:
7.129



IMPACT FACTOR:
7.429



INTERNATIONAL JOURNAL FOR RESEARCH

IN APPLIED SCIENCE & ENGINEERING TECHNOLOGY

Call : 08813907089  (24*7 Support on Whatsapp)