



IJRASET

International Journal For Research in
Applied Science and Engineering Technology



INTERNATIONAL JOURNAL FOR RESEARCH

IN APPLIED SCIENCE & ENGINEERING TECHNOLOGY

Volume: 8 Issue: VI Month of publication: June 2020

DOI: <http://doi.org/10.22214/ijraset.2020.6311>

www.ijraset.com

Call:  08813907089

E-mail ID: ijraset@gmail.com

IOT based Sun Tracing TrashBot

Sharadhi G R¹, Akhila Madhu²

^{1,2}Electronics & Communication Department, PES University, Bangalore, Karnataka, India

Abstract: *Historical and current energy systems are dominated by fossil fuels (coal, oil and gas) which produce carbon dioxide and greenhouse gases which is the fundamental driver of global climate change. Increased demand for electricity in current days has led to research and development in efficient usage of the alternate forms of energy. Solar energy is one of the most abundantly available renewable, eco-friendly forms of energy.*

Collection of garbage is a matter of great concern in most cities of India. It is hazardous to everybody especially garbage collectors since waste disposal happens in a haphazard fashion. With Covid-19 being a pandemic in the current scenario, hygiene should be the first priority. Usage of a greener, cleaner, feasible form of energy is promoted by the proposed model in our research which focuses on a solar powered garbage collecting robot based on Internet of Things (IOT).

Although some components of this research have practical aspects, integration of all components is theoretical and may not be a practical one, unless proven.

Keywords: *Solar, energy, garbage, robot, renewable, hygiene, internet*

I. INTRODUCTION

In the present day lifestyle, everyone is inclined towards usage of several appliances and gadgets to reduce labour and comfort themselves. Energy consumption is increasing due to which its production is enormous. With this rate of usage, fossil fuels are depleting, paving the way for looking at other alternatives.

To protect our nature, the alternative energy forms should be non-polluting, investments should be comparatively less and able to obtain maximum output with considerably less time. One such form of energy is solar energy which is available abundantly in India and free of cost. Sunlight, or solar energy, can be used directly for heating and lighting homes and workspaces, for generating electricity, and for hot water heating, solar cooling, and a variety of other commercial and industrial applications. Here, in our research we shall see how engineering methods are incorporated in producing electricity from solar energy to build a healthy and clean environment.

Our objective is to utilise the sun's energy in a productive way by building a garbage collecting robot which has a sunlight tracing system to get maximum incident sunrays. Infusion of Internet of Things into this ideology provides us with data analysis, real time monitoring of solar power generated and utilised.

II. INDIA'S PROPOSITION FOR SOLAR ENERGY BASED PROJECTS

Being the second most populated country in the world, we are utilising electricity in humungous amounts. At this rate we will run out of all fossil fuels and face serious national crisis.

A. Economic Value

The generation of solar electricity coincides with the normal peak demand during daylight hours in most places, thus mitigating peak energy costs, brings total energy bills down, and obviates the need to build as much additional generation and transmission capacity as would be the case without PV.

B. Geographical Location

India being a tropical country receives adequate solar radiation for 300 days, amounting to 3,000 hours of sunshine equivalent to over 5,000 trillion kWh. Almost all the regions receive 4-7 kWh of solar radiation per square meters with about 2,300-3,200 sunshine hours/year, depending upon the location.

C. Power Shortage

Electricity losses in India during transmission and distribution have been extremely high over the years and this reached a worst proportion of about 24.7% during 2010-11. India is in a pressing need to tide over a peak power shortfall of 13% by reducing losses due to theft. Theft of electricity, common in most parts of urban India, amounts to 1.5% of India's GDP. Due to shortage of electricity, power cuts are common throughout India and this has adversely affected the country's economic growth.

III. WASTE MANAGEMENT PROBLEM IN INDIA

With rapid urbanisation, the country is facing massive waste management challenge. Over 377 million urban people live in 7,935 towns and cities and generate 62 million tonnes of municipal solid waste per annum. Only 43 million tonnes (MT) of the waste is collected, 11.9 MT is treated and 31 MT is dumped in landfill sites. Solid Waste Management (SWM) is one among the basic essential services provided by municipal authorities in the country to keep urban centres clean. However, almost all municipal authorities deposit solid waste at a dump yard within or outside the city haphazardly. Experts believe that India is following a flawed system of waste disposal and management.

The problem of waste is not limited to the metro cities but it is going unchecked across India. As per the annual report of the Indian government's Ministry of Housing and Urban Affairs, it is estimated that the total generation of solid waste is approximately 150,000 tons per day and of that, approximately 90 per cent (135,000 tons per day) is collected. Out of the collected waste, 20 per cent (27,000 tons per day) is processed and the remaining 80 per cent goes to the dump sites.

With over one fifth of the world's population residing in India, this has a massive impact on not just our country but our planet. A clean environment should be a basic fundamental right of every living creature but it doesn't just happen, we have to make it happen.

IV. WORKING OF COMPONENTS

A. Solar Panel

Solar cells are building blocks of solar panel. It is a device similar to diode. It converts light energy to electrical energy. When light is allowed to fall on the cells, the voltage increases with increase in light intensity. Cell is designed such that large area is exposed to light which enhances voltage generation across terminals.

It consists of silicon PN junction diode covered with glass window on top surface of P material which is made extremely thin so that the incident light's photons can reach the PN junction easily. When photons collide with valence electrons, they transfer sufficient energy so that these electrons can leave their parent atom. In this way free electrons and holes are generated on both sides of junction and current is produced. This current is directly proportional to illumination and also the size of surface area being illuminated. Many solar cells are combined together to form solar panel.

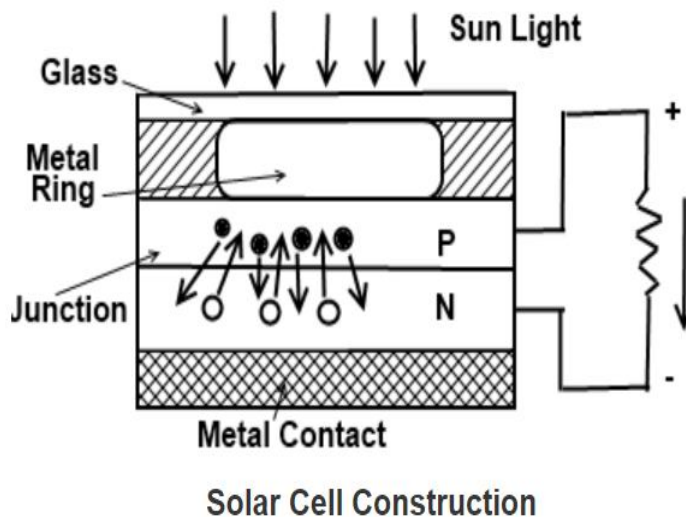

Fig. 1 Solar Panel

B. Arduino microcontroller and Arduino IDE

Arduino is an open source platform based on an easy-to-use hardware and software. It has a circuit board, that can be programmed and ready-made software called Arduino IDE (Integrated Development Environment), which is used to write and upload the computer code to the physical board.

The board has analog and digital pins to which hardware components like LED, sensors; Wi-Fi module can be connected. The board directs them to perform certain tasks according to codes written in Arduino IDE. It does not require additional hardware to load the programme. Arduino IDE uses simplified version of C++ making it easy to learn and write programmes.

Arduino provides a standard form factor that breaks the functions of the micro-controller into a more accessible package.

C. IR Sensor

The basic concept of an Infrared Sensor which is used as obstacle detector is to transmit an infrared signal, this infrared signal bounces from the surface of an object and the signal is received at the infrared receiver.

D. Ultrasonic Sensor

An ultrasonic sensor is an electronic device that measures the distance of a target object by emitting ultrasonic sound waves, and converts the reflected sound into an electrical signal. Ultrasonic waves travel faster than the speed of audible sound (i.e. the sound that humans can hear).

E. Servo Motor

A servo motor is an electrical device which can push or rotate an object with great precision. It allows rotating and orienting at some specific angles or distance. It is made up of simple motor which runs through servo mechanism. Servo motors are rated in kg/cm (kilogram per centimetre).

F. Motor Driver IC

A motor driver IC is an integrated circuit chip which is usually used to control motors in autonomous robots. Motor driver ICs act as an interface between microprocessors and the motors in the robot. We have used L239d motor driver IC.

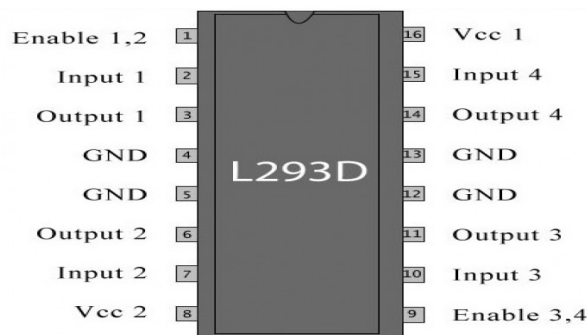

Fig 2. L239d motor driver IC

G. LDR(Light Dependent Resistor)

LDR's are made from semiconductor materials to enable them to have their light-sensitive properties. Whenever light falls on the surface of the LDR (in this case) the conductance of the element increases and hence the resistance of the LDR falls.

H. Torque Motor

Torque motor is an electronic device in which the generated torque is used to run the wheels of the robot attached to its shaft. Here we have used four 100 rpm (revolution per minute) motor controlled by two motor drivers IC (one IC controls two motors)

V. IMPLEMENTATION

A. Solar Tracing System

LDR (Light Dependent Resistor) is working as light detector. LDR also known as photo resistor is a light sensitive device. Its resistance decreases when light falls on it.

Two light dependent resistors are arranged on the edges of the solar panel. A voltage divider circuit is made using LDR and 10000 ohm resistors. The output of voltage divider network is given to analog pin of Arduino microcontroller which senses the voltage and directs the servo motor to rotate the panel as follows.

- 1) If more amount of light falls on right LDR, panel moves towards right side.
- 2) If more amount of light falls on left LDR, panel moves towards left side.
- 3) If equal amount of light falls on both LDR, panel remains stationary.

The below figure depicts the circuit diagram of Solar Tracing System. 'S' indicates Servo motor.

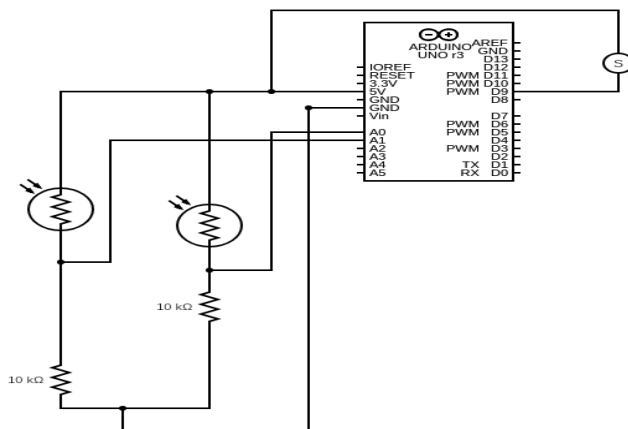

Fig 3. Circuit Diagram of Solar Tracer

```

sketch_jan18a | Arduino 1.8.12 (Windows Store 1.8.33.0)
File Edit Sketch Tools Help
sketch_jan18a
#include <Servo.h> //including the library of servo motor
Servo sg90; //initializing a variable for servo named sg90
int initial_position = 90; //Declaring the initial position at 90
int LDR1 = A2
; //Pin at which LDR is connected
int LDR2 = A1; //Pin at which LDR is connected
int error = 5; //initializing variable for error
int servopin=9;
void setup()
{

  sg90.attach(servopin); // attaches the servo on pin 9
  pinMode(LDR1, INPUT); //Making the LDR pin as input
  pinMode(LDR2, INPUT);
  sg90.write(initial_position); //Move servo at 90 degree
  delay(2000); // giving a delay of 2 seconds
}

void loop()
{
  int R1 = analogRead(LDR1); // reading value from LDR 1
  int R2 = analogRead(LDR2); // reading value from LDR 2
  int diff1= abs(R1 - R2); // Calculating the difference between the LDR's
  int diff2= abs(R2 - R1);

  if((diff1 <= error) || (diff2 <= error)) {
    //if the difference is under the error then do nothing
  } else {
    if(R1 > R2)
    {
      initial_position = --initial_position; //Move the servo towards 0 degree
    }
    if(R1 < R2)
    {
      initial_position = ++initial_position; //Move the servo towards 180 degree
    }
  }
  sg90.write(initial_position); // write the position to servo
  delay(100);
}

```

Fig 4. Arduino code of sunlight tracer circuit- screenshot

B. Trash Collector Robot

The solar powered garbage collection robot is designed purely by technical means. This robot collects garbage which is of similar dimensions to that of juice cartons, plastic bottles, crushed papers, disposed Covid-19 masks, and all light items whose height is between 5 to 20 centimetres from public spaces such as gardens, bus stands, footpaths. In sequence, the method is identification of the needs required. These needs are analysed to get specific components. These components are later integrated to get the desired output.

Components used are Arduino Uno, IR sensor, Ultra sonic sensor, 100 rpm motor, l239d motor driver IC, servo motor.

The robot travels a random path across a given area using four geared 100 rpm motors which are connected to the Arduino Mega with the help of two l293d motor driver IC. Two infrared sensors are connected on either side of the bot. These help in detecting the garbage. One UV sensor is placed in the middle on the chassis to obtain accurate distance measurements. The bot then adjusts itself through pre-programmed code such that the picking mechanism/clamp is in front of the obstacle. The chassis is made using metal which makes the robot more durable.

The trash collection mechanism consists of two pedals/cups mounted on a shaft connected to the servo motors. This mechanism has two degrees of freedom (vertical and circulatory). The mechanism will not operate for entirety of the vehicle operation and will rotate only for predetermined set of conditions.

The mechanism is mounted on the front side of the base. When the bot encounters garbage, it adjusts itself in such a way that the trash is centered and 25 centimeter away from the chassis of bot. After these conditions are met, the shaft is brought down vertically followed by the pedals turning inwards picking up the garbage. The shaft then hurls upwards putting the garbage piece in the bin attached to the back of the chassis. The bot collects garbage till the bin fills up.

The bin has IR sensor which acts like level sensors. With IOT, we can track the amount of waste in the bin.

Once the bin is full, it should be emptied manually.

The motor driver circuit is used for the motion of the robot. The robot requires a motion controlling unit i.e. Arduino Uno kit with adapter. Automatic motion of robot is obtained by using sensors in the navigation system. Arduino Mega is micro controller which facilitates the functionality of robot in real time.

All the components in the bot are powered by a 12V battery which is charged by solar panels.

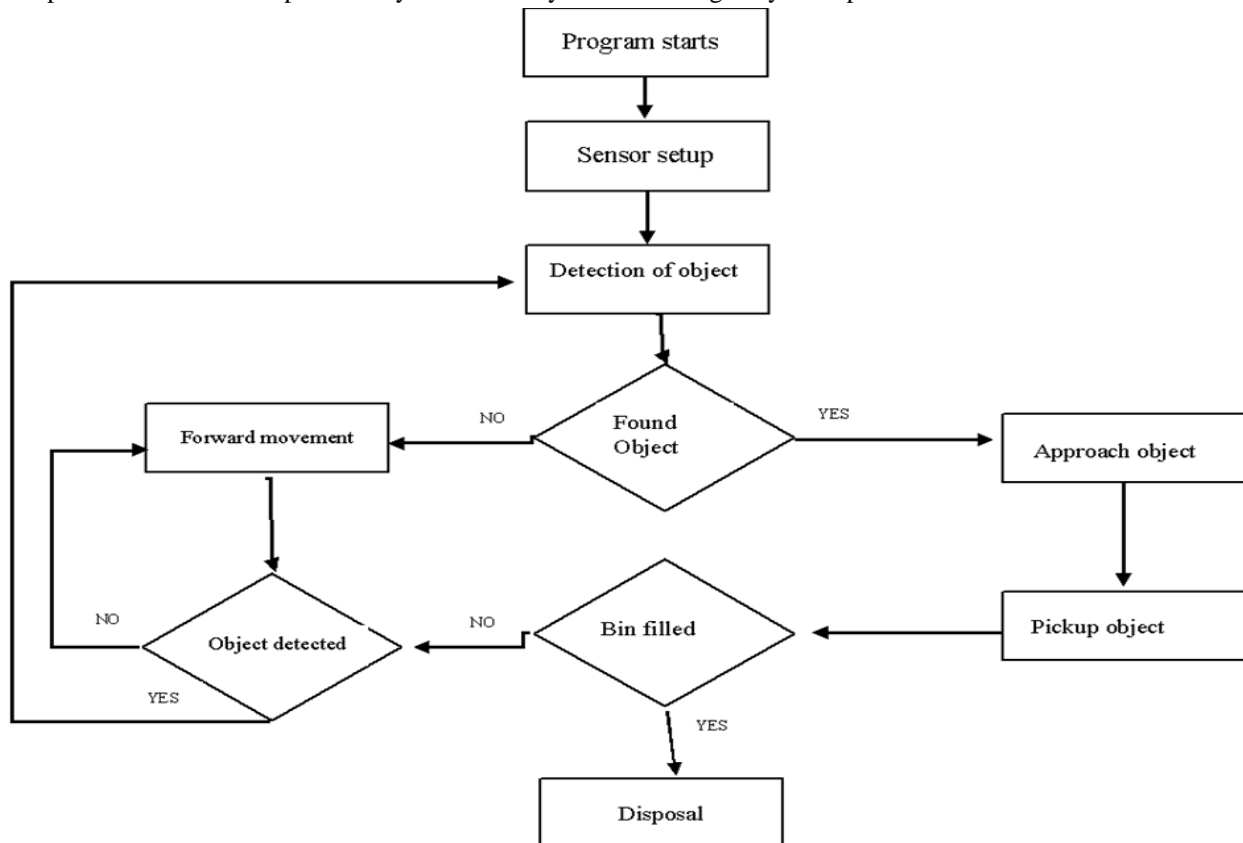

Fig 5. Flowchart of Trash Collector Bot

C. Infusion of IOT

The Internet of Things (IoT) shall be able to incorporate transparently and seamlessly a large number of different systems, while providing data for millions of people to use and capitalize. Building a general architecture for the IoT is hence a very complex task, mainly because of the extremely large variety of devices, link layer technologies, and services that may be involved in such a system.

The main benefit of using IoT in solar energy applications is that we can monitor real time activities from one central control panel. By connecting the devices to a cloud network, data analysis becomes easier and flexible. Without IoT, it would be difficult to determine whether the problem was network-related or hardware-related. The IoT provides the intelligence to identify issues in real time, as the error occurs the source can be located and resolved quickly.

In addition to providing with real-time alerts, leveraging IoT in solar energy can lead to improvements in power quality and performance by collecting historical data for modelling.

Connecting the solar garbage collection robot to a Wi-Fi module like NODEMCU connects it to the internet. Firebase by Google can be used for real-time database. Data regarding the position of sunlight, sensor values of LDRs, the amount of current and voltage generated, consumed by the solar panels can be fed to the cloud using Microsoft Azure services. An android mobile application can also be made which may provide notification alerts regarding the changing values of real time data. By this methodology, one can easily serve two purposes of using a greener source of energy to have a clean environment.

VI. LIMITATIONS

Energy generated by a single panel is not sufficient. More panels should be connected in series or parallel depending on the requirement. Additional boost converters to be used to obtain more voltage from panel. Output of every panel varies since uniform light intensity is not available throughout the day. Robot can pick only garbage having small weights. Proper path planning required for the robot to save the generated solar energy. Garbage segregation while collection is not taken care.

VII. CONCLUSION

Proposed methodology reduces the huge dependence on non-renewable energy sources and paves way for sustainable energy production. Leveraging IoT in solar energy can lead to improvements in power quality and performance by collecting historical data for modelling. Using IoT in solar energy can solve many of these issues with little effort and investment. Solar powered robot helps to maintain a healthier surrounding and also exhibits efficient garbage picking mechanism, reducing labour.

VIII. ABBREVIATIONS

IOT, Internet of Things; PV, photovoltaic; kWh, kilo watt hour; GDP, gross domestic product; LDR, light dependent resistor; rpm, revolutions per minute; IC, integrated circuit; LED, light-emitting diode; IR, infra-red; MT, million tonnes; SWM, solid waste management; IDE, integrated development environment.

REFERENCES

- [1] Solar heating and cooling technologies.[Online].Available: <https://www.seia.org/research-resources/solar-heating-and-cooling>
- [2] India's unique proposition.[Online].Available: <http://www.eai.in/ref/ae/sol/sol.html>
- [3] India's challenges in waste management.[Online].Available: <https://www.downtoearth.org.in/blog/waste/india-s-challenges-in-waste-management-56753>
- [4] Working of solar cell.[Online].Available: <https://www.daenotes.com/electronics/industrial-electronics/solar-cell-working-construction>
- [5] Arduino working.[Online].Available: <https://www.arduino.cc/en/guide/introduction>
- [6] Infrared, ultrasonic sensors working.[Online].Available: <https://www.fierceelectronics.com/sensors>
- [7] Working of servo motor.[Online].Available: <https://engineering.eckovation.com/servo-motor-types-working-principle-explained/>
- [8] Working of motor driver IC.[Online].Available: <https://2020.robotix.in/>
- [9] LDR working principle.[Online].Available: <https://www.electrical4u.com/light-dependent-resistor-ldr-working-principle-of-ldr/>
- [10] Torque motor working.[Online].Available: <https://www.magneticinnovations.com/faq/torque-motor-how-it-works/>
- [11] Future of IOT in solar energy .[Online].Available: <https://www.sierrawireless.com/iot-blog/>



10.22214/IJRASET



45.98



IMPACT FACTOR:
7.129



IMPACT FACTOR:
7.429



INTERNATIONAL JOURNAL FOR RESEARCH

IN APPLIED SCIENCE & ENGINEERING TECHNOLOGY

Call : 08813907089  (24*7 Support on Whatsapp)