



iJRASET

International Journal For Research in
Applied Science and Engineering Technology



INTERNATIONAL JOURNAL FOR RESEARCH

IN APPLIED SCIENCE & ENGINEERING TECHNOLOGY

Volume: 3 Issue: VII Month of publication: July 2015

DOI:

www.ijraset.com

Call:  08813907089

E-mail ID: ijraset@gmail.com

A Novel Technique to Support Voltage Control for Statcom under Unbalanced Voltage Sag

Koilpaka Himabindu¹, K.Jaghannath²

^{1,2}Dept. of EEE, SVS Institute of Technology, Warangal, Telangana, India

Abstract—Static synchronous compensators have been broadly employed for the provision of electrical ac network services, which include voltage regulation, network balance, and stability improvement. Several studies of such compensators have also been conducted to improve the ac network operation during unbalanced voltage sags. This paper presents a complete control scheme intended for synchronous compensators operating under these abnormal network conditions. In particular, this control scheme introduces two contributions: a novel reactive current reference generator and a new voltage support control loop. The current reference generator has as a main feature the capacity to supply the required reactive current even when the voltage drops in amplitude during the voltage sag. Thus, a safe system operation is easily guaranteed by fixing the limit required current to the maximum rated current. The voltage control loop is able to implement several control strategies by setting two voltage set points. In this paper, three voltage support control strategies are proposed, and their advantages and limitations are discussed in detail. The two theoretical contributions of this paper have been validated by experimental results. Certainly, the topic of voltage support is open for further research, and the control scheme proposed in this paper can be viewed as an interesting configuration to devise other control strategies in future works.

Index Terms—Power quality, reactive power control, static synchronous compensator (STATCOM), voltage sag.

I. INTRODUCTION

The traditional configuration of the electrical ac network is nowadays changing. High penetration of renewable energy sources, located close to the point of power consumption, is noticed in recent years [1]. With small transmission and distribution distances, power losses are clearly reduced. In addition, the reduction of the network congestion, the improvement of local power quality, and the provision of ancillary services are notable advantages of the present distributed power generation scenario [2]. Reactive power exchange with the ac network is one of the ancillary services provided by the distributed renewable energy sources. This service can be used to greatly increase the margin to voltage collapse and, thus, to improve the stability of the electrical network. Reactive power is also employed for voltage regulation, network balance, and voltage support during transient abnormal conditions [3]–[6].

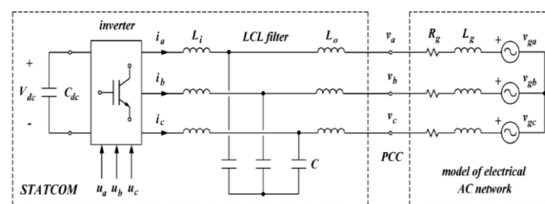

Fig. 1. Diagram of the power system, including the STATCOM and the model of the electrical ac network.

Section II presents the STATCOM considered in this paper. Section III introduces the new reactive current reference generator. Section IV derives the voltage control scheme and proposes several voltage support control strategies. The advantages and limitations of the proposed strategies are discussed. Section V validates the theoretical contributions by experimental results. Section VI is the conclusion.

II. SYSTEM DESCRIPTION

This section describes the STATCOM, including the power circuit topology and the control system. In addition, it introduces the basic concepts necessary to study the system.

A. STATCOM

Fig. 1 shows the diagram of the STATCOM considered in this paper. The power circuit topology includes a three-phase VSC, a dc-side capacitor C_{dc} , and an LCL output filter. In transmission and distribution power systems, the STATCOM is normally connected

International Journal for Research in Applied Science & Engineering Technology (IJRASET)

to the point of common coupling (PCC) through a step-up transformer. In Fig. 1, inductor L_o represents the leakage inductance of the STATCOM transformer (the magnetizing inductance is not considered here). The electrical network is represented by a grid impedance (R_g and L_g) in series with an ac voltage source. The grid impedance physically models other power system transformers as well as the line impedance. Note that the values of R_g , L_g , and v_g are the reflected quantities to the primary side of the STATCOM transformer. The voltage at the PCC and the current at the converter side \mathbf{i} are sensed and supplied to the control system. This current is preferred for control purposes instead of the current at the ac network side (flowing through L_o) due to the improvement achieved in the system robustness.

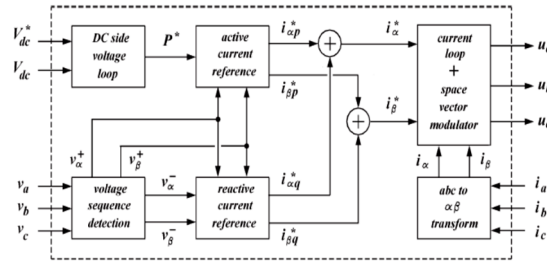

Fig. 2. Diagram of the STATCOM control system.

B. Control System

The control system for the STATCOM should provide control input \mathbf{u} in accordance to the following objectives.

The capacitor voltage V_{dc} should be regulated to the dc voltage set point V_{dc}^* . This ensures the absorption of a small active power from the ac network necessary to compensate for power losses.

The maximum current should not be exceeded. A current set point I^* is employed in the control system to perform this task (see Section III).

The PCC voltage should be regulated between set points V_{max}^* and V_{min}^* , which are the maximum and minimum voltages at the PCC, respectively. Three control strategies to set the values for these set points during unbalanced voltage sags are presented and discussed in Section IV.

The previous objectives are accomplished with the control system shown in Fig. 2. The control consists of an external voltage loop, an internal current loop, and a space vector modulator. The internal loop is a tracking regulator designed to provide fast and accurate current control. Proportional and resonant regulators are employed for this task. In the Laplace domain, these compensators are implemented by the following transfer function (both in α and β current channels):

$$H(s) = k_{p,c} + \sum_{m=1,5,7,11} \frac{k_{m,c} 2\xi_c(m\omega_g)s}{s^2 + 2\xi_c(m\omega_g)s + (m\omega_g)^2} \quad (1)$$

with s being the Laplace operator, $k_{p,c}$ being the proportional gain, $k_{m,c}$ being the resonant gain, ξ_c being the damping factor, and m being the selected harmonics. Further details about these regulators can be found. The external loop is responsible for generating the current references, expressed in (2) and (3), according to the set points V_{dc}^* and I^* as follows:

$$i_{\alpha}^* = i_{\alpha p}^* + i_{\alpha q}^* \quad (2)$$

$$i_{\beta}^* = i_{\beta p}^* + i_{\beta q}^* \quad (3)$$

with $i_{\alpha p}^*$ and $i_{\beta p}^*$ and $i_{\alpha q}^*$ and $i_{\beta q}^*$ being the active and reactive current references, respectively. A key element in the external loop is the voltage sequence detector. This detector extracts the positive- and negative-sequence voltages at the PCC as follows:

$$v_{\alpha} = v_{\alpha}^+ + v_{\alpha}^- \quad (4)$$

$$v_{\beta} = v_{\beta}^+ + v_{\beta}^- \quad (5)$$

These symmetrical voltage components can be defined as

$$v_{\alpha}^+ = V^+ \cos(\omega t + \varphi^+) \quad (6)$$

$$v_{\beta}^+ = V^+ \sin(\omega t + \varphi^+) \quad (7)$$

$$v_{\alpha}^- = V^- \cos(-\omega t - \varphi^-) \quad (8)$$

$$v_{\beta}^- = V^- \sin(-\omega t - \varphi^-) \quad (9)$$

Note that, in general, amplitudes V^+ and V^- , angular frequency ω , and initial phases φ^+ and φ^- are time-varying signals. These

International Journal for Research in Applied Science & Engineering Technology (IJRASET)

signals can be computed online as

$$V^+ = \sqrt{(v_\alpha^+)^2 + (v_\beta^+)^2} \quad (10)$$

$$V^- = \sqrt{(v_\alpha^-)^2 + (v_\beta^-)^2} \quad (11)$$

$$\cos(\varphi^+ - \varphi^-) = \frac{v_\alpha^+ v_\alpha^- - v_\beta^+ v_\beta^-}{V^+ V^-} \quad (12)$$

$$\sin(\varphi^+ - \varphi^-) = \frac{v_\alpha^+ v_\beta^- - v_\beta^+ v_\alpha^-}{V^+ V^-} \quad (13)$$

Several voltage sequence detectors can be found in literature to extract the above information. In this paper, the detector reported was employed. It implements a band pass filter tuned at the fundamental grid frequency to extract in-phase signal v_e and a low-pass filter to obtain in-quadrature signal v_q , in both α and β voltage channels. The filters are frequency adaptive in order to track properly the variable frequency of the grid voltage. The transfer functions of the filters can be written as

$$\frac{v_e(s)}{v(s)} = \frac{2\xi_v \omega_e s}{s^2 + 2\xi_v \omega_e s + \omega_e^2} \quad (14)$$

$$\frac{v_q(s)}{v(s)} = \frac{\omega_e^2}{s^2 + 2\xi_v \omega_e s + \omega_e^2} \quad (15)$$

with ξ_v being the damping factor and ω_e being the estimated grid frequency. It is worth mentioning that this voltage sequence separator gives high harmonic rejection due to its band pass filter nature.

The current supplied to the ac network during unbalanced voltage sags can be highly distorted by harmonics. By using the given sequence detector, together with the following active current references [3], the current harmonics are strongly reduced:

$$i_{\alpha p}^* = \frac{2}{3} \frac{v_\alpha^+}{(V^+)^2} P^* \quad 16$$

$$i_{\beta p}^* = \frac{2}{3} \frac{v_\beta^+}{(V^+)^2} P^* \quad 17$$

where P^* is the active power reference. As shown in Fig. 2, this signal is generated by the dc-side voltage loop, which is implemented here as a conventional proportional–integral (PI) regulator.

The reactive current references

$$i_{\alpha q}^* = \frac{2}{3} \frac{k_q v_\beta^+ + (1 - k_q) v_\beta^-}{k_q (V^+)^2 + (1 - k_q) (V^-)^2} Q^* \quad (18)$$

$$i_{\beta q}^* = \frac{2}{3} \frac{-k_q v_\alpha^+ - (1 - k_q) v_\alpha^-}{k_q (V^+)^2 + (1 - k_q) (V^-)^2} Q^* \quad (19)$$

also provide low harmonic distortion when they are employed together with the aforementioned voltage sequence detector. These references, specifically for voltage support, are the starting point to derive a new reactive current reference generator with a current set point instead of a reactive power set point (see Section III).

C. Voltage Unbalance Factor

An essential characteristic of the electrical ac network is the voltage unbalance factor. This factor indicates the amount of negative sequence found at the PCC (in relation to the positive sequence). It can be defined as

$$n = \frac{V^-}{V^+} \quad (20)$$

Ideally $n = 0$, meaning that the network voltage is balanced. In normal conditions, this factor is small, i.e., typically $n < 0.02$. During unbalanced voltage sags, however, high values of n are expected. The factor is frequently within the range of $0.1 < n < 0.4$, although higher values are also possible.

III. REACTIVE CURRENT REFERENCE GENERATOR

The first contribution of this paper is a reactive current reference generator. This section is devoted to the derivation of this generator. In particular, in this section, the expressions of the reference signals that fix the maximum amplitude of the phase currents to a predefined value (i.e., the set point I^*) are deduced. This objective should also be reached when the phase currents are unbalanced. In addition, at the end of this section, the mechanism of reactive power injection of the proposed current reference generator is revealed through the analysis of the positive- and negative-sequence reactive power.

International Journal for Research in Applied Science & Engineering Technology (IJRASET)

A. Maximum Reactive Power Delivered To The AC Network

By inserting (6)–(9) and (20) into (18)–(19), the stationary reference frame current references can be expressed as a function of time. Then, an expression for the phase current references in the natural frame is easily obtained by using the inverse Clarke transformation. The amplitudes of these current references are

$$I_x^* = \frac{2}{3} \frac{\sqrt{k_q^2 - 2nk_q(1 - k_q) \cos x + n^2(1 - k_q)^2} Q^*}{k_q + n^2(1 - k_q)} \frac{Q^*}{V^+} \quad (21)$$

where $x = a, b, \text{ or } c$, and the function $\cos x$ can be written as

$$\cos x = \cos \left(\varphi^+ - \varphi^- + m \frac{2\pi}{3} \right) \quad (22)$$

where $m = 0, 1, \text{ or } 2$. From (21), it is easy to note that the currents are balanced if the voltage is balanced ($n = 0$), i.e.,

$$I_a^* = I_b^* = I_c^* = \frac{2}{3} \frac{Q^*}{V^+}. \quad (23)$$

In addition, the currents are balanced (even during unbalanced voltage conditions, $n > 0$) if the control gain $k_q = 1$ or $k_q = 0$. With $k_q = 1$, the current amplitudes satisfy (23). For $k_q = 0$, the current amplitudes can be expressed as

$$I_a^* = I_b^* = I_c^* = \frac{2}{3} \frac{Q^*}{nV^+}. \quad (24)$$

For k_q values inside the range of $0 < k_q < 1$, the currents are unbalanced. In this case, the phase current with higher amplitude should be considered to establish the limits of the reactive power. For this purpose, the current set point I^* is

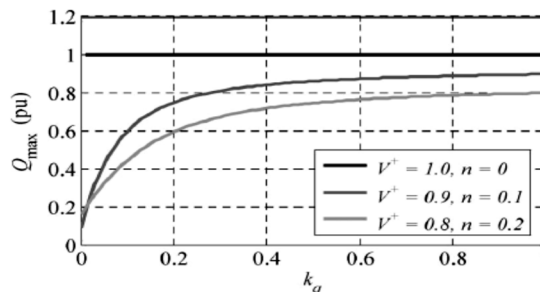

Fig. 3. Maximum reactive power versus control gain k_q and for several values of V^+ and n ($I_{\max} = 1$ p.u., $\cos_{\min} = -0.5$), defined as the higher phase current amplitude, and from (21), it can be written as

$$I^* = \frac{2}{3} \frac{\sqrt{k_q^2 - 2nk_q(1 - k_q) \cos_{\min} + n^2(1 - k_q)^2} Q^*}{k_q + n^2(1 - k_q)} \frac{Q^*}{V^+} \quad (25)$$

where the function \cos_{\min} is

$$\cos_{\min} = \min(\cos x). \quad (26)$$

Note that the minimum value of (22) is necessary to calculate the current set point (i.e., the maximum phase current) given that the term $2nk_q(1 - k_q) \cos_{\min}$ has a negative sign in (25). Thus, the maximum reactive power Q_{\max} injected to the ac network is calculated from (25) by replacing the current set point by the maximum STATCOM rated current I_{\max} , i.e.,

$$Q_{\max} = \frac{3}{2} \frac{(k_q + n^2(1 - k_q)) V^+}{\sqrt{k_q^2 - 2nk_q(1 - k_q) \cos_{\min} + n^2(1 - k_q)^2}} I_{\max}. \quad (27)$$

B. Proposed Reactive Current Reference Generator

The reference generator is derived by inserting the reactive power reference from (25) to (18) and (19), resulting in

$$i_{\alpha q}^* = \frac{k_q v_{\beta}^+ + (1 - k_q) v_{\beta}^-}{\sqrt{k_q^2 - 2nk_q(1 - k_q) \cos_{\min} + n^2(1 - k_q)^2}} \frac{I^*}{V^+} \quad (28)$$

$$i_{\beta q}^* = \frac{-k_q v_{\alpha}^+ - (1 - k_q) v_{\alpha}^-}{\sqrt{k_q^2 - 2nk_q(1 - k_q) \cos_{\min} + n^2(1 - k_q)^2}} \frac{I^*}{V^+}. \quad (29)$$

International Journal for Research in Applied Science & Engineering Technology (IJRASET)

Some inputs of (28) and (29) can be calculated online by the voltage sequence detector. The voltage unbalance factor n is obtained by using (10), (11), and (20). The function \cos_{\min} is computed using (12), (13), and (26). Positive- and negative sequence components of the PCC voltage are directly obtained at the output of the voltage sequence detector, as shown in Fig. 2. However, the two remaining inputs (the set point I^* and the control gain k_q) should be chosen in order to fulfill a specific control objective, as discussed in the following. The current set point is certainly the maximum amplitude of the phase currents, as can be easily deduced from (21) and (25). Thus, an accurate selection of the current set point is enough to guarantee a safe STATCOM operation, i.e.,

$$0 \leq I^* \leq I_{\max}. \quad (30)$$

C. Reactive Power Injection

The positive- and negative-sequence reactive power injected to the ac network can be defined as [8]

$$q^+ = \frac{3}{2} \left(-v_{\alpha}^+ i_{\beta}^+ + v_{\beta}^+ i_{\alpha}^+ \right) \quad (31)$$

$$q^- = \frac{3}{2} \left(-v_{\alpha}^- i_{\beta}^- + v_{\beta}^- i_{\alpha}^- \right). \quad (32)$$

By inserting (6)–(9), (28), and (29) in the given expressions, the reactive power provided by the STATCOM when the proposed reactive current reference generator is used can be written as

$$q^+ = \frac{3}{2} \frac{k_q V^+}{\sqrt{k_q^2 - 2nk_q(1 - k_q) \cos_{\min} + n^2(1 - k_q)^2}} I^* \quad (33)$$

$$q^- = \frac{3}{2} \frac{n^2(1 - k_q)V^+}{\sqrt{k_q^2 - 2nk_q(1 - k_q) \cos_{\min} + n^2(1 - k_q)^2}} I^*. \quad (34)$$

It is worth mentioning that when the voltage is balanced ($n = 0$) or by setting $k_q = 1$ in case of imbalance voltage ($n > 0$), the reactive power is injected via positive sequence only, i.e.,

$$q^+ = \frac{3}{2} V^+ I^* \quad q^- = 0. \quad (35)$$

By setting $k_q = 0$ in the case of imbalance voltage, the reactive power is delivered via a negative sequence only, i.e.,

$$q^+ = 0 \quad q^- = \frac{3}{2} V^- I^*. \quad (36)$$

IV. VOLTAGE SUPPORT CONTROL STRATEGIES

The second contribution of this paper is a voltage support control scheme intended for STATCOMs under unbalanced voltage sags. This section is devoted to the derivation of this

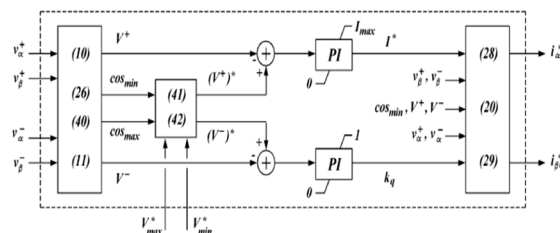

Fig. 4. Diagram of the proposed reactive current reference generator with voltage support auxiliary service.

voltage control. In addition, three voltage support control strategies are introduced and discussed in detail.

V. SIMULATION MODEL AND RESULTS

International Journal for Research in Applied Science & Engineering Technology (IJRASET)

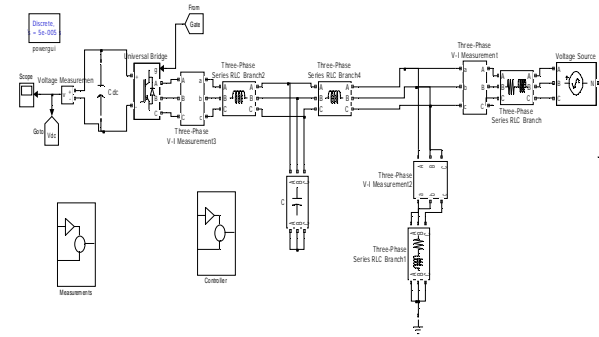

Fig.5. Simulation model for proposed circuit

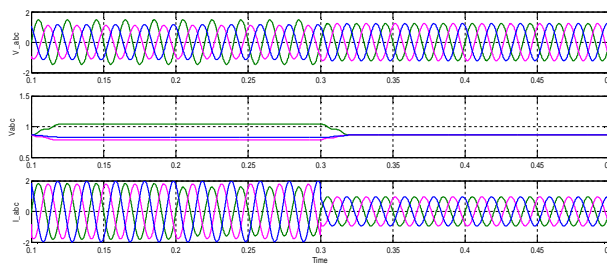

Fig.6. Simulation results of STATCOM operation in steady state and under the voltage- PCC Voltage (V_{abc}), RMS voltage (V_{RMS}), Current (I_{abc}), I^* and K_q .

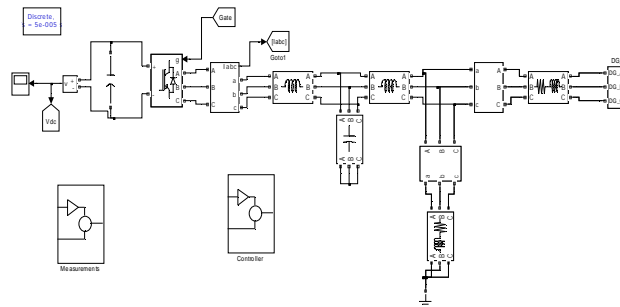

Fig.7. Simulation model for proposed circuit

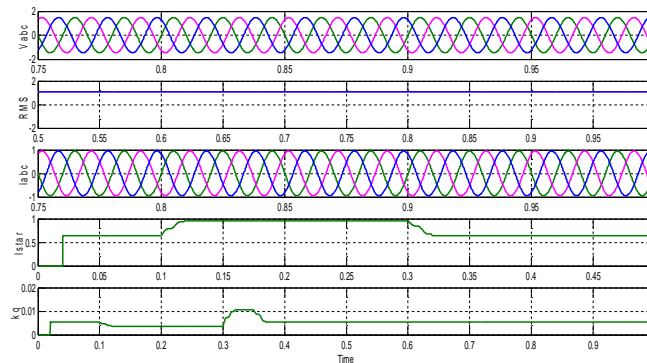

Fig.8. Simulation results of STATCOM When $K_q=1$ - PCC Voltage (V_{abc}), RMS voltage (V_{RMS}), Current (I_{abc}), I^* and K_q .

International Journal for Research in Applied Science & Engineering Technology (IJRASET)

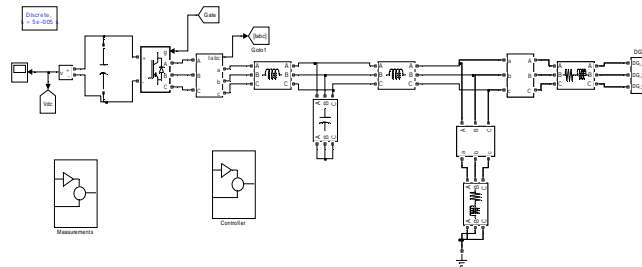

Fig.9. Simulation model for proposed circuit

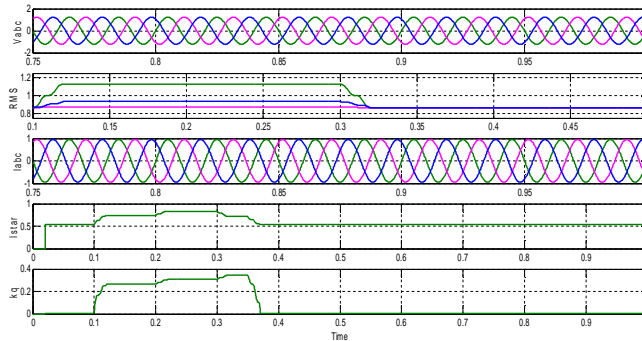

Fig.10. Simulation results of STATCOM when $K_q=0.5$ – PCC Voltage (V_{abc}), RMS voltage (V_{RMS}), Current (I_{abc}), I^* and K_q .

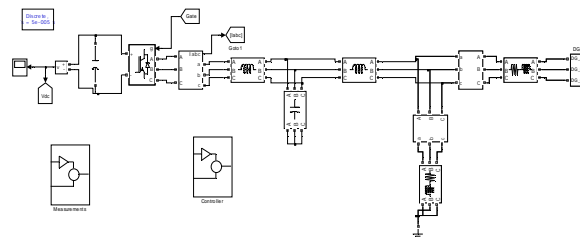

Fig.11. Simulation model for proposed circuit

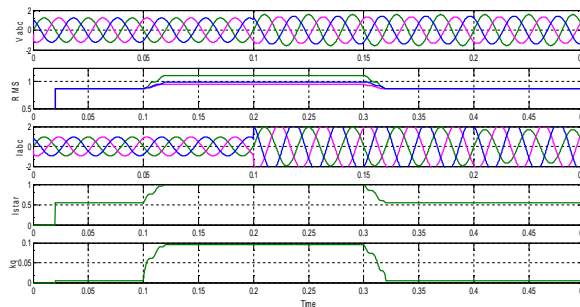

Fig.12. Simulation results when STATCOM is in active_ mode – PCC Voltage (V_{abc}), RMS voltage (V_{RMS}) and current (I_{abc}), I^* and K_q .

VI. CONCLUSION

A complete control scheme intended for STATCOMs operating under unbalanced voltage sags has been presented in this paper. The first contribution is a reactive current reference generator programmed with a current set point instead of the conventional reactive power set point. As an interesting feature, this generator guarantees a safe operation of the STATCOM by naturally limiting the amplitude of the current delivered to the ac network. The main advantage in comparison with previous reference generators is that

International Journal for Research in Applied Science & Engineering Technology (IJRASET)

the online calculation of the maximum reactive power is not required since the output limits in the proposed algorithm are constant values even in the presence of grid voltages with imbalances. The second contribution is a voltage control loop that makes possible the introduction of several voltage support control strategies by simply modifying two voltage set points. Three control strategies are proposed to verify the effectiveness of the control scheme under severe unbalanced voltage sags. The CS1 has good results in normal network conditions but has poor results during abnormal conditions with significant voltage imbalance. In fact, a STATCOM with higher power rating is required to supply the necessary reactive current to fulfill the requirements specified by the CS1. The CS2 and CS3 relax the stringent specifications of CS1 and provide good results during the unbalanced voltage sag by changing the position of the voltage set points. The main differences between these strategies are as follows: 1) CS2 requires the minimum injection of reactive current by positioning the voltage set points at the limits specified in grid codes for normal operation; and 2) CS3 achieves the lower negative-sequence voltage at the PCC by adaptively positioning the voltage set points in accordance with the reactive current injection. In that case, the voltage limits are not exceeded with a certain room for security. In comparison with existing voltage control loops based on a voltage-reactive power droop characteristic, the proposed control ensures an accurate voltage regulation to a predefined voltage set point provided that the STATCOM rated power and the impedance of the ac network are large enough. This feature will be particularly appreciated in a future scenario where the penetration of the distributed power plants will be high enough to replace some conventional power generators. Actually, the topic of voltage support control strategies is open for further research, and the synthesis of novel control strategies implemented with the proposed voltage control scheme is left to future work.

REFERENCES

- [1] J. M. Carrasco, L. G. Franquelo, J. T. Bialasiewicz, E. Galván, R. C. Guisado, M. A. Prats, J. I. León, and N. Moreno-Alfonso, "Power electronic systems for the grid integration of renewable energy sources: A survey," *IEEE Trans. Ind. Electron.*, vol. 53, no. 4, pp. 1002–1016, Jun. 2006.
- [2] F. Blaabjerg, R. Teodorescu, M. Liserre, and A. V. Timbus, "Overview of control and grid synchronization for distributed power generation systems," *IEEE Trans. Ind. Electron.*, vol. 53, no. 5, pp. 1398–1409, Oct. 2006.
- [3] P. Rodriguez, A. Timbus, R. Teodorescu, M. Liserre, and F. Blaabjerg, "Independent PQ control for distributed power generation systems under grid faults," in *Proc. IEEE IECON*, 2006, pp. 5185–5190.
- [4] A. Luna, P. Rodriguez, R. Teodorescu, and F. Blaabjerg, "Low voltage ride through strategies for SCIG wind turbines in distributed power generation systems," in *Proc. IEEE PESC*, 2008, pp. 2333–2339.
- [5] P. Rodriguez, A. Timbus, R. Teodorescu, M. Liserre, and F. Blaabjerg, "Reactive power control for improving wind turbine system behavior under grid faults," *IEEE Trans. Power Electron.*, vol. 24, no. 7, pp. 1798–1801, Jul. 2009.
- [6] F. Wang, J. L. Duarte, and M. A. Hendrix, "Pliant active and reactive power control for grid-interactive converters under unbalanced voltage dips," *IEEE Trans. Power. Electron.*, vol. 26, no. 5, pp. 1511–1521, May 2011.



10.22214/IJRASET



45.98



IMPACT FACTOR:
7.129



IMPACT FACTOR:
7.429



INTERNATIONAL JOURNAL FOR RESEARCH

IN APPLIED SCIENCE & ENGINEERING TECHNOLOGY

Call : 08813907089  (24*7 Support on Whatsapp)