



IJRASET

International Journal For Research in
Applied Science and Engineering Technology



INTERNATIONAL JOURNAL FOR RESEARCH

IN APPLIED SCIENCE & ENGINEERING TECHNOLOGY

Volume: 8 Issue: VII Month of publication: July 2020

DOI: <https://doi.org/10.22214/ijraset.2020.30555>

www.ijraset.com

Call:  08813907089

E-mail ID: ijraset@gmail.com

Investigation on the Distortional Buckling Behaviour of Cold-Formed SupaCee Beam with Different Web Hole Shape and Crimped Flanges

Ms. Vidya Venugopal M¹, Mrs. Divya K K²

¹M. Tech Structural Engineering Student, Dept. of Civil Engineering, Vedavyasa Institute of Technology, Malappuram

²Associate Professor, Dept. of Civil Engineering, Vedavyasa Institute of Technology, Malappuram

Abstract: Thin walled cold-formed steel sections are widely used in the construction industry as primary structural and non-structural components because of their light weight and high strength properties. SupaCee sections are new sections with strengthened cross section than the traditional lipped channel section. This study investigated the distortional buckling behaviour of cold formed SupaCee beams provided with various shapes of web perforations and also with crimped flanges. Web openings are provided in the beam sections to allow access for building services like electric wires and pipelines. Past researches have shown that the introduction of holes causes reduction of both buckling capacity and strength of the member. In this study, the effect of web hole shapes in the distortional buckling of cold-formed SupaCee beams were analysed and the best perforated SupaCee model was compared with the model without web openings. Crimps were introduced into the flanges of best perforated model obtained for the strengthening purpose. The finite element modelling and analysis is done by using ANSYS workbench 16.1 software. From this investigation it is obtained that SupaCee beam with hexagonal web perforations shows the best result and introduction of crimped flanges increased the buckling resistance of the section. The comparison study with the non-perforated model shows that the introduction of holes into the SupaCee beam section reduced the load carrying capacity of the member.

Keywords: Cold-formed steel, SupaCee sections, Crimped flanges, Distortional buckling, Web perforations, Lipped channel section

I. INTRODUCTION

Cold-formed steel sections are now more popular in the modern building construction as secondary load bearing members due to their easy fabrication process, large volume production and higher strength to weight ratio. The cold rolling process can be employed to make steel of almost any desired shape to any desired length. The earliest building which has used cold formed steel was a hospital named Virginia Baptist hospital founded in 1924. In this building cold formed steel sections are used for the floors. Cold formed steel (CFS) sections are used as structural elements like columns, beams, joists, studs, floor decking and built up sections. These members are also used in railway coaches, highway products, bridges, building structures, car bodies, firearms etc. In thin walled perforated cold-formed steel (PCFS), openings are found in the web of cold formed steel beams. They are provided to allow access for building services like plumbing, electrical and heating systems in walls and ceiling of the buildings. The presence of opening not only changes the stress distribution within the member but it also affects the mode of failure when the structure is loaded. The introduction of holes may also leads to the decrease in cross section. PCFS section when subjected to compression or bending, they may experience three types of buckling modes. These three types of buckling modes are local buckling, distortional buckling and global buckling. Therefore in the behaviour of thin perforated plates and thin walled sections buckling is an important aspect to consider. The critical buckling stress of PCFS sections are difficult to determine directly. This is because of the various parameters like opening shape, size and location. Studies had found that bending stiffness of the plate was reduced by the hole and in the plate strips near to the hole there must be concentration of axial stress.

SupaCee sections are new sections with strengthened cross section than traditional lipped channel section. These web stiffened channel section consist of a ribbed web and curved lips compared to conventional section. SupaCee sections are more economical and they give increased strength compared to traditional channel section because of their unique ribbed web element. Fig. 1 shows a web stiffened channel section, i.e. SupaCee section. These sections are commonly used for roof and floor systems in structures. Therefore they have adequate bending, shear and bearing capacities.

At the point of transverse concentrated loading or supports, SupaCee sections are subjected to localized web crippling failures. However the studies regarding the buckling analysis of perforated cold formed SupaCee steel sections are not done yet.

In this paper, the analytical investigation on the distortional buckling behaviour of perforated cold-formed SupaCee beams is conducted using finite element method. Different shapes of web perforations are introduced into this beam sections and the influence of various web hole shape on the load carrying capacity of the member is examined. Also a comparison study is done between the perforated and non-perforated SupaCee beam models. Finally, crimps are introduced into the flanges of best perforated model for strengthening purpose and the distortional buckling behaviour is examined.

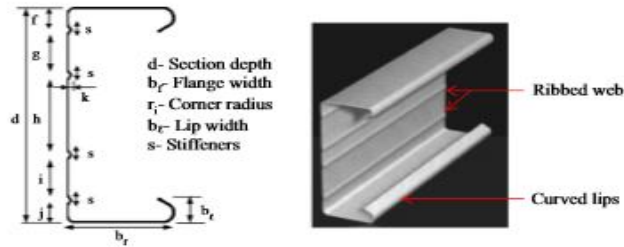

Fig. 1 SupaCee channel section

II. OBJECTIVE

- A. To analyse the buckling behaviour of SupaCee beam with different hole shape in web opening
- B. To compare the buckling behaviour of perforated SupaCee beam model with model without web openings
- C. To analyse the behaviour of crimped effects in strengthening of web opening in SupaCee beam

III. MODELLING OF PERFORATED SUPACEE BEAM

A SupaCee channel beam consists of ribbed web with four stiffeners which can provide better strength than conventional lipped channel beams. Structural steel is the material used for the construction of SupaCee channel section. The SupaCee channel beam is modelled as per the dimensions suggested by Lavan Sundararajah et.al [2] in his research regarding web crippling capacity and then perforations are introduced into this beam section as per the reference values based on the research paper by Wei-bin Yuan et.al [16]. The geometric and material properties of the SupaCee beam specimen used for the study are shown in Table I and Table II. The geometric properties of the SupaCee channel beam includes the web thickness (t_w), section depth (d) and inside bent radius (r_i) which is provided according to the detailing shown in the figure 1. The length of the beam provided for the study is 1099.6 mm. The SupaCee channel beam is simply supported at its two ends and the load is applied at the top centre span of the beam.

Table I Geometric Properties of the SupaCee Beam Model

Beam specimen	Dimensions
Bearing length (l_b)	50 mm
Web thickness (t_w)	1.53 mm
Flange thickness (t_f)	1.53 mm
Inside bent radius (r_i)	5 mm
Flange width (b_f)	69.7 mm
Lip width (b_l)	22.9 mm
Specimen length (L)	609 mm
f	14.5 mm
g	32.4 mm
h	55.9 mm
i	22.6 mm
j	18.6 mm
s	12 mm
k	3.6 mm

Table II Material Properties of Model Specimen

Properties	Steel
Yield strength (MPa)	541
Young's modulus (MPa)	2×10^5
Poisson's ratio	0.3
Density (kg/m^3)	7850

The finite element software ANSYS 16.1 is used to perform the nonlinear finite element analysis of SupaCee beam models. ANSYS has the ability to consider any nonlinearity in the beam model provided. The SupaCee beam sections are modelled by using solid 186 elements and shell 181 element type is used for the modelling of loading and support bearing plates.

A. Case 1 Perforated SupaCee Beam with Different Shapes of Web Hole

In this study, different shapes of web holes are introduced into the perforated SupaCee beams for finding out the best perforated model. The web holes are placed equally along the web of the beam and in each model the shape of the web perforation is changed by keeping constant hole area. The study is carried out using circular, square, elliptical and hexagonal web openings. The length of the perforated SupaCee beam modelled is 1099.6 mm. The diameter of the circular web hole is assumed to be 100 mm and the dimensions of other hole shapes are calculated by fixing the same hole area obtained for the circular openings. Table III shows the dimensions provided for the different hole shapes and the finite element models of perforated SupaCee beams with various hole shapes are depicted in the Fig. 2.

Table III Dimensions of Web Openings

Hole shape	Dimension (mm)
Diameter of the circular web hole	100
Sides of square web hole	88.6
Major and minor axis length of elliptical web hole	55 and 45.45
Sides of hexagonal web hole	54.98

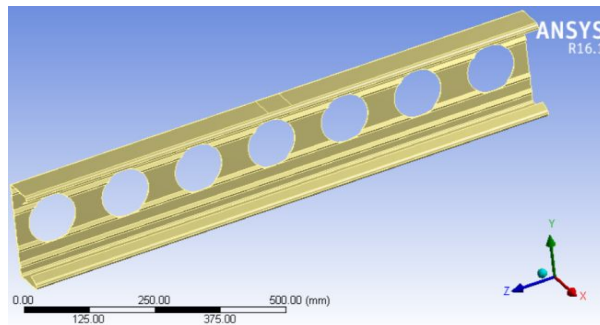

(a) Circular web hole

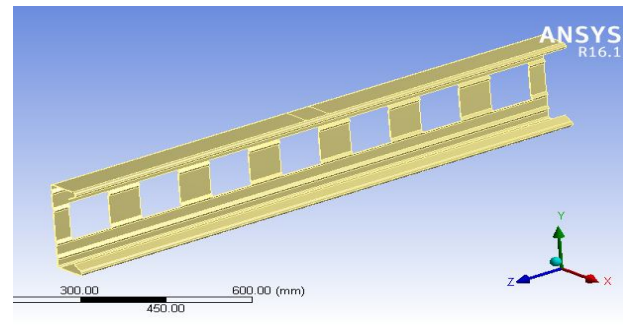

(b) Square web hole

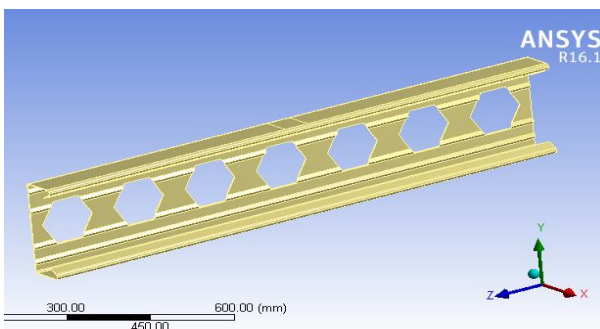

(c) Hexagonal web hole

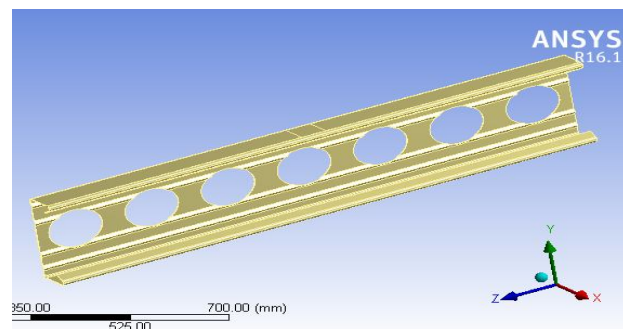

(d) Elliptical web hole

Fig. 2 SupaCee beam models with different web hole shape

The boundary condition and loading is applied as same for all the perforated beam models. Fig. 3 shows the support and loading condition of hexagonal perforated SupaCee beam model.

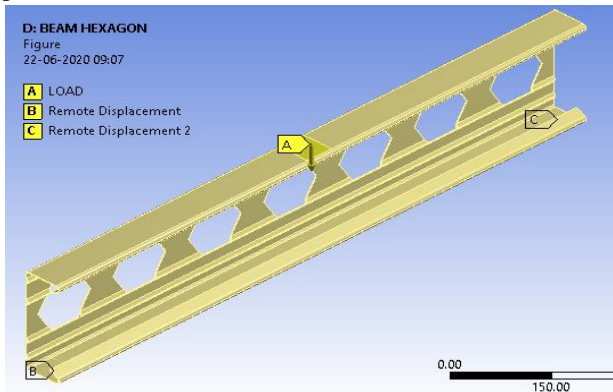

Fig. 3 Support and loading condition of hexagonal perforated SupaCee beam

B. Case 2 SupaCee Beam without Web Perforations for the Comparison Study

SupaCee beams are modelled with the same dimensions as in the above models without making perforations in the web. Model without web openings are done to compare with the perforated models. Fig. 4 shows the finite element model of non-perforated SupaCee beam.

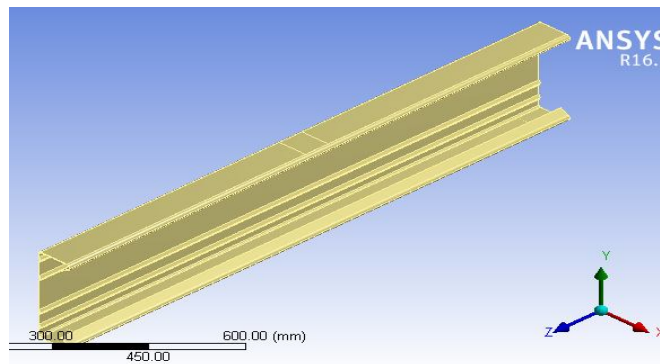

Fig. 4 Finite element model of SupaCee beam without web openings

C. Case 3 Hexagonal Perforated SupaCee Beam with Crimped Flanges

The effect of crimp in the flanges of perforated SupaCee beam model is investigated in this study. From the parametric study done on the web hole shapes, it is obtained that SupaCee beam with hexagonal web openings shows the best result. Therefore crimps are made on the flanges of hexagonal perforated SupaCee beam for strengthening the beam model. Crimps are placed on the top and bottom flanges of the perforated SupaCee beam. A single crimp is provided on both the flanges with a bend degree of 90°. Fig. 5 shows the model of hexagonal perforated SupaCee beam with crimped flanges.

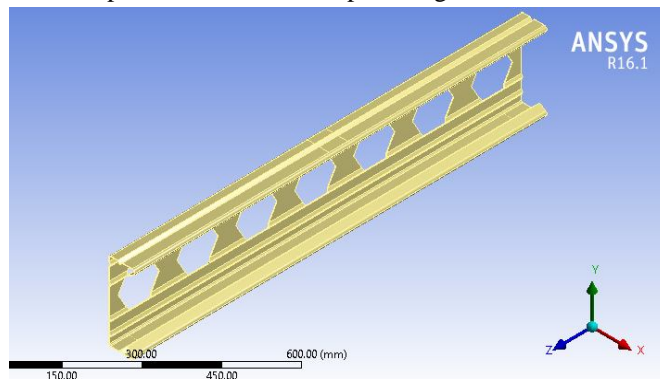

Fig. 5 Finite element model of hexagonal perforated SupaCee beam with crimped flanges

IV. ANALYSIS AND RESULTS

Nonlinear static analysis is done for solving all these models using the ANSYS software. The failure pattern of each specimen is obtained after the analysis process. The load and the corresponding deformation values obtained from the study on different shapes of web holes and without web holes on SupaCee beam sections are given in the Table IV. The load deformation curve plotted between the maximum load and the corresponding deformation of beam sections are shown in Fig. 6.

Table IV Load and Deformation of SupaCee Beam with Different Hole Shapes and without Hole

Hole shape	Load (kN)	Deformation (mm)
Circular hole	12.986	23.867
Square hole	13.272	21.587
Elliptical hole	12.399	21.2
Hexagonal hole	14.648	30.331
Without hole	18.962	23.231

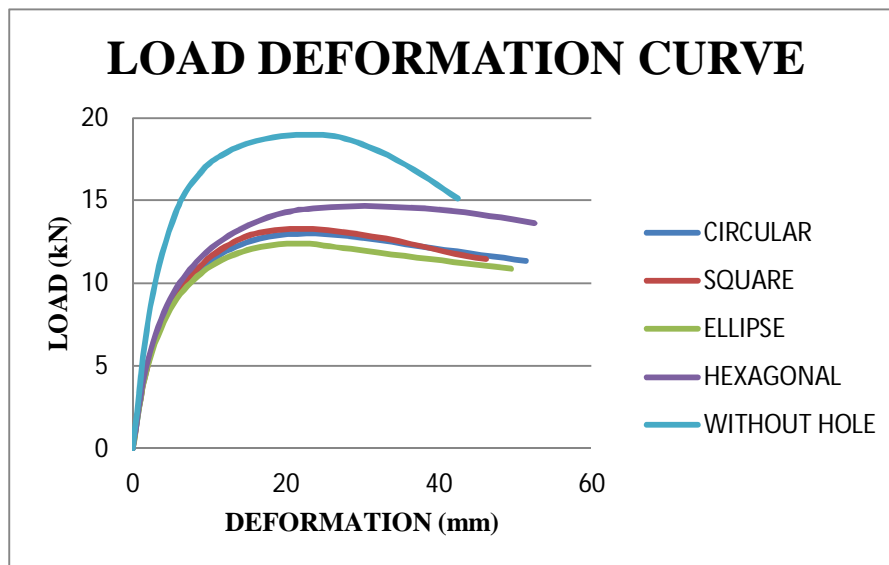

Fig. 6 Load deformation curve of different hole shapes and without holes

From the above table and graph, it is clear that in perforated SupaCee beam sections, the hexagonal shape opening shows the best performance when compared to other preferred hole shapes. This is because the hexagonal perforated SupaCee beam takes the maximum load than the other perforated models. The hexagonal perforated SupaCee beam has attained a maximum load of 14.648 kN with a corresponding deformation of 30.331 mm. When comparing this perforated sections with that of section without holes, the perforated SupaCee beam has low load carrying capacity than SupaCee beam without holes. Fig. 7 shows the total deformation of hexagonal perforated SupaCee beam.

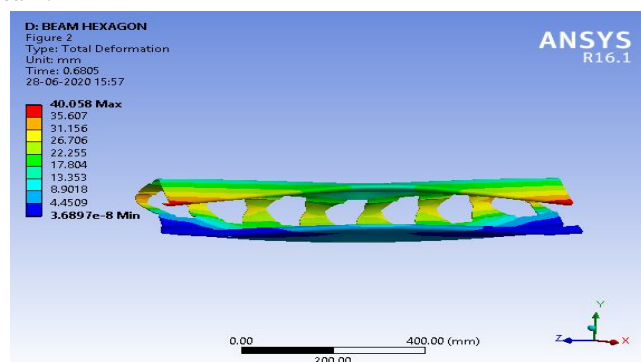

Fig. 7 Total deformation of hexagonal perforated SupaCee beam

The deformed shape of the hexagonal perforated SupaCee beam shows that the failure cause is mainly due to distortional buckling. The buckling is mainly experienced around the web hole and flange region. The best perforated model, ie hexagonal perforated model is taken for the further studies of strengthening purpose.

The load and corresponding deformation of hexagonal perforated SupaCee beam with crimped flanges are given in Table V. Using this maximum load attained and its corresponding deformation, load deformation curve is plotted for hexagonal perforated SupaCee beam with crimped flanges which is shown in Fig. 8.

Table V Load and Deformation of Hexagonal Perforated SupaCee Beam with Crimped Flanges

Model	Load (kN)	Deformation (mm)
Perforated SupaCee beam with crimped flanges	14.052	26.746

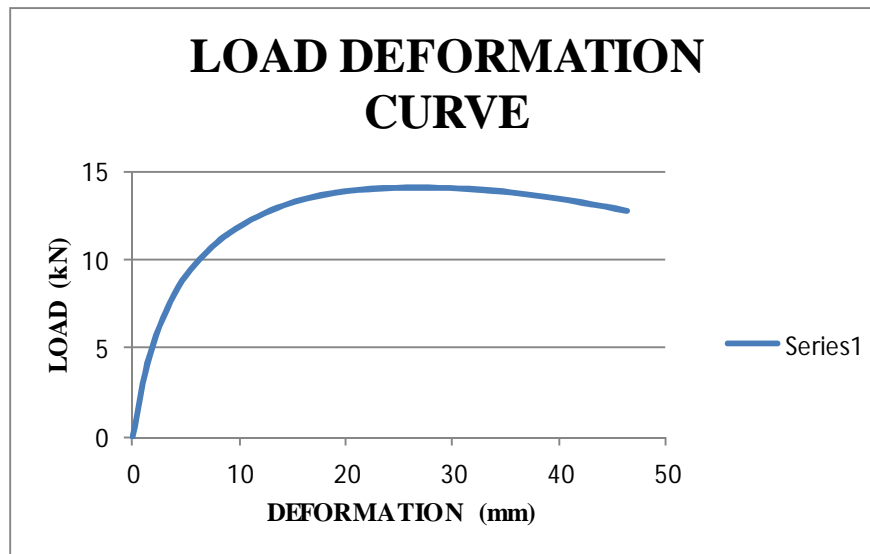

Fig. 8 Load deformation curve of hexagonal perforated SupaCee beam with crimped flanges

From the table and graph, it is observed that SupaCee beam with crimped flanges has attained a similar maximum load of 14.052 kN with decrease in deformation from 30.331 mm to 26.746 mm corresponding to the load value when compared to the non-strengthened perforated beam section. Fig. 9 shows the total deformation of hexagonal perforated SupaCee beam with crimped flanges.

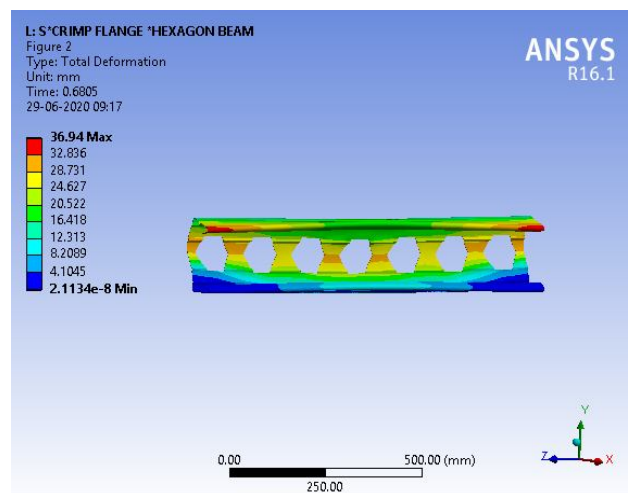

Fig. 9 Total deformation of hexagonal perforated SupaCee beam with crimped flanges

The deformed shape of perforated beam with crimped flanges shows that the distortional buckling observed in the beam section has reduced to a lower level by the introduction of crimps in flanges. So the introduction of crimped flanges in the hexagonal perforated SupaCee beam gives a strengthened model than the beam without crimped flanges.

V. CONCLUSIONS

The aim of this paper is to investigate the buckling behaviour of perforated cold-formed SupaCee beam sections with different hole shapes and minimising the buckling of best performed perforated cold formed SupaCee steel section by the introduction of crimped flanges. The load carrying capacities of these sections are investigated using FEA modelling and analysis. The following conclusions are obtained from the analysis:

- A. The study on various shapes of web holes shows that hexagonal web openings have the maximum load carrying capacity on perforated SupaCee beam.
- B. The deformations observed from the analysis shows that the perforated SupaCee beam section undergoes distortional buckling.
- C. Comparison study on hexagonal perforated cold-formed SupaCee beam with that of these sections without holes indicate that perforations found on the web of the sections minimise the load carrying capacity of these members.
- D. Introduction of crimps in the flanges of hexagonal perforated SupaCee beam attains a maximum load carrying capacity with a reduction in the deformation level.
- E. Thus hexagonal perforated SupaCee beam with crimped flanges gives a strengthened model with reduced buckling behaviour.

VI. ACKNOWLEDGMENT

I would like to express my sincere gratitude to my guide Associate professor, Divya K K in Civil Engineering Department for her constant support and guidance. I am also thankful to my parents, friends and above all the god almighty for the successful completion of this work.

REFERENCES

- [1] B. Janarthanan, L. Sundararajah, M. Mahendran, P. Keerthan and S. Gunalan (2019) Web crippling behaviour and design of cold-formed steel sections, Thin-Walled Structures, 140, 387-403
- [2] Lavan Sundararajah, Mahen Mahendran and Poolaganathan Keerthan (2017) Web crippling studies of SupaCee sections under two flange load cases, Engineering Structure, 153, 582-597
- [3] Nan-Ting Yu, Boksun Kim, Long-yuan Li, Wei-jian Hong and Wei-bin Yuan (2020) Distortional buckling of perforated cold-formed steel beams subject to uniformly distributed transverse loads, Thin-Walled Structures, 148, 1-8
- [4] Nan-ting Yu, Boksun Kim, Wei-bin Yuan, Long-yuan Li and Feng Yu (2019) An analytical solution of distortional buckling resistance of cold-formed steel channel section beams with web openings, Thin-Walled Structures, 135, 446-452
- [5] Amir M. Yousefi, James B.P. Lim and G. Charles Clifton (2018) Cold-formed ferritic stainless steel unlippped channels with web perforations subject to web crippling under one-flange loadings, Construction and Building Materials, 191, 713-725
- [6] Cao Hung Pham (2017) Shear buckling of plates and thin-walled channel sections with holes, Journal of Constructional Steel Research, 128, 800-811
- [7] Jinyou Zhao, Kuo Sun, Cheng Yu and Jun Wang (2019) Tests and direct strength design on cold-formed steel channel beams with web holes, Engineering Structures, 184, 434-446
- [8] Jue Zhu and Long-yuan Li (2016) A stiffened plate buckling model for calculating critical stress of distortional buckling of CFS beams, International Journal of Mechanical Sciences, 115-116, 457-464
- [9] Krishanu Roy, Tina Chui Huon Ting, Hieng Ho Lau and James B.P. Lim (2018) Nonlinear behaviour of back-to-back gapped built-up cold-formed steel channel sections under compression, Journal of Constructional Steel Research, 147, 257-276
- [10] Lavan Sundararajah, Mahen Mahendran and Poolaganathan Keerthan (2016) Experimental studies of lipped channel beams subject to web crippling under two-flange load cases, Journal of Structural Engineering, ISSN 0733-9445, 1-6
- [11] Liping Wang and Ben Young (2017) Design of cold-formed built-up sections with web perforations subjected to bending, Thin-Walled Structures, 120, 458-469
- [12] Liping Wang and Ben Young (2015) Beam tests of cold-formed steel built-up sections with web perforations, Journal of Constructional Steel Research, 115, 18-33
- [13] Man-Tai Chen, Ben Young, Andre Dias Martins, Dinar Camotim and Pedro Borges Dinis (2020) Uniformly bent CFS lipped channel beams experiencing local-distortional interaction: Experimental investigation, Journal of Constructional Steel Research, 170, 1-18
- [14] Nirosha Dolamune Kankanamge and Mahen Mahendran (2012) Behaviour and design of cold-formed steel beams subject to lateral-torsional buckling, Thin-Walled Structures, 51, 25-38
- [15] Sivaganesh Selvaraj and Mahendrakumar Madhavan (2019) Structural design of cold-formed steel face-to-face connected built-up beams using direct strength method, Journal of Constructional Steel Research, 160, 613-628
- [16] Wei-bin Yuan, Nan-ting Yu and Long-yuan Li (2017) Distortional buckling of perforated cold-formed steel channel-section beams with circular holes in web, International Journal of Mechanical Sciences, 126, 255-260



- [17] Gustavo Y. Matsbara, Eduardo de M. Batista and Guilherme C. Salles (2019) Lipped channel cold-formed steel columns under local-distortional buckling mode interaction, *Thin-Walled Structures*, 137, 251-270
- [18] David C. Fratamico, Shahabeddin Torabian, Xi Zhao, Kim J.R. Rasmussen and Benjamin W. Schafer (2018) Experiments on the global buckling and collapse of built-up cold-formed steel columns, *Journal of Constructional Steel Research*, 144, 65-80
- [19] Jue Zhu, Chong Ren, Xu Zhang, Xuhao Huang and Wenhua Ye (2019) Dynamic analysis of cold formed steel channel-section columns under axial impact loading, *Engineering Failure Analysis*, 102, 260-269
- [20] Rinchen and Kim J.R. Rasmussen (2019) Behaviour and modelling of connections in cold-formed steel single C- section portal frames, *Thin-Walled Structures*, 143, 1-16
- [21] EN 1993-1-3; Eurocode 3– Design of steel structures – Part 1-3; General rules – Supplementary rules for cold-formed members and sheeting



10.22214/IJRASET



45.98



IMPACT FACTOR:
7.129



IMPACT FACTOR:
7.429



INTERNATIONAL JOURNAL FOR RESEARCH

IN APPLIED SCIENCE & ENGINEERING TECHNOLOGY

Call : 08813907089  (24*7 Support on Whatsapp)