



# IJRASET

International Journal For Research in  
Applied Science and Engineering Technology



---

# INTERNATIONAL JOURNAL FOR RESEARCH

IN APPLIED SCIENCE & ENGINEERING TECHNOLOGY

---

**Volume: 8    Issue: VIII    Month of publication: August 2020**

**DOI: <https://doi.org/10.22214/ijraset.2020.31205>**

**[www.ijraset.com](http://www.ijraset.com)**

**Call:  08813907089**

**E-mail ID: [ijraset@gmail.com](mailto:ijraset@gmail.com)**

# Design of Garri Frying Machine with User-defined Temperature Regulation and Motion Control System

Uchenna Godswill Onu<sup>1</sup>, Kufre Esenowo Jack<sup>2</sup>, Emmanuel Ozioko Nwangwu<sup>3</sup>

<sup>1</sup>Department of Electrical/Electronic Engineering Technology, School of Engineering Technology, Akanu Ibiam Federal Polytechnic, Unwana, Nigeria.

<sup>2</sup>Department of Mechatronics Engineering, School of Electrical Engineering & Technology, Federal University of Technology Minna, Niger State, Nigeria.

<sup>3</sup>Department of Electrical/Electronic Engineering Technology, School of Engineering Technology, Akanu Ibiam Federal Polytechnic, Unwana, Nigeria.

**Abstract:** Cassava as a food crop has since secured a prominent space in the food chain of African countries. This important crop has to its advantage various mode of preparation for consumption. One of the most natural preserving states of cassava food is the garri state. Garri is obtained from raw cassava roots through a chain of processes ranging from uprooting, peeling, washing, grating, pressing, sieving to frying. Frying as a part of the processing chain in garri production poses a lot of health hazards to the farmer and environment due to heat and smokes emanating from the process. Existing garri frying machines have temperature and motion control limitations. This research focuses on the design of a garri frying machine with user-defined temperature regulation and motion control system. This is geared towards solving the problem created by lack of automated control of temperature and motion systems in existing garri frying machines. The design was modelled using Proteus simulation environment. Temperature and motion limits were set and maintained with the help of hardware programming through Arduino Integrated Development Environment (IDE). The results obtained from the simulation tests showed effective regulation and control of temperature of the heating system and speed of the drive system respectively. The resulting machine will encourage massive investment in cassava value chain to guarantee food security with minimal health risks in garri frying process.

**Keywords:** Garri frying machine; Cassava; Temperature; Motion; Control system

## I. INTRODUCTION

Food ranks first in the scale of human basic needs. Man in his quest to provide this important need has explored his environment by planting, harvesting and processing of various food crops. The use of cassava as food in America began around 18<sup>th</sup> century BC [1]. Cassava as food for man has long been available making it possible for man to explore varying methods of its preparation and preservation as food. According to [2] cassava as food around the world is prepared in variety of ways according to local customs including fufu, mingao, manicuera, dumby, farina, cassareep, ampesi, cassava rice, macaroni, cassava pudding, tiwul, wafers fried chips, garri and others. A study by [3] revealed that majority of households in Ohaozara, Ebonyi State, Southeast Nigeria consume garri as some cassava products. This may not be quite different in other neighboring towns in the country. According to [4], garri is partially gelatinized free-flowing granular flour with a slightly fermented flavor and sour taste which constitutes the most consumed and sold variety of food from cassava roots.

The processing of this all important food has attracted the attentions of many scholars as a departure from the traditional methods that involve the use of fire and manual labor in frying garri. [5] designed a mechanically driven garri frying machine to reduce the exposure of the operator to heat, however the design still requires human effort to drive the pedal. In this proposed research, human involvement will be limited to minimum by introducing an automatic control system to regulate rotation and heating of the garri frying process.

In a related development [6] proposed an electric garri frying and arrived at the specifications of the proposed machine through computer aided design and computations. The researcher could not implement the design hence the need for a design that can be implemented with an improved human independence. [7] designed an automated garri frying machine that uses charcoal as source of heat. The authors reported improved performance of the machine with a 20kg /hr production rate at 20rpm optimum speed of operation.

Environmental concerns are important factors to be considered in any sustainable design, in this research, effort is targeted at developing a more environmentally sustainable design by using electric power to drive the heating and turning process in garri frying. This will reduce deforestation caused by tree falling for charcoal production. An improved garri fryer was developed by [8] with throughput capacity and functional efficiency of 6.6 kg/hr and 75 % respectively. The authors used cooking gas as source of heat. This design seeks to maintain a high level of human independence by using electricity to power the entire frying process with adequate control and regulation. A solar power supply system can also be used to power the machine and as such makes it possible for the machine to be used in rural areas where grid energy supply is not always available.

Coincidentally, a design that took into cognizance the need to develop synthesis and select appropriate materials for an improved garri frying machine was proposed by [9], however this design did not include electrical control unit. This research will use electrical control unit to regulate the heating and motion of a garri frying machine. [10] achieved rotation through the use of electric motor, however heating was still by charcoal application. A major attempt to develop temperature control in garri frying machine was made by [11] where gelatinization and frying temperatures were stabilized using a PID Microcontroller-MATLABSIMULINK simulation schematic model. The authors recommended that future researches be done in the area of controller design, hence the proposal of this research to explore hardware programming options in order to achieve temperature and motion control.

As a summary, various researchers have worked on developing mechanized garri frying machines; however, there is a research gap in effective temperature and motion control as garri frying requires variations in heating temperature at various frying stages. This research is aimed at filling this gap by using a microcontroller approach in ensuring a user defined temperature and motion control setting.

## II. AIM AND OBJECTIVES

The main aim of this research is set to design a garri frying machine with user-defined temperature regulation and motion control system. This will be achieved by the following secondary objectives;

- A. To design a temperature regulation unit;
- B. To design a motion control unit and
- C. To design a human machine interface and display unit

## III. MATERIALS AND METHODS

### A. Materials

The materials used in this design are electrical and electronic components with associated simulation software.

The following components were used for the design.

- 1) Power Supply outlet (220V Ac)
- 2) Single pole single through Switch
- 3) Transformer (220V Ac/ 150V Ac)
- 4) Diode(IN4001)
- 5) Resistors (1K $\Omega$ )
- 6) Temperature sensor LM35
- 7) Push button Switch
- 8) Capacitor (1000uf)
- 9) Arduino Uno Microcontroller
- 10) Keypad (HMI)
- 11) Transistor (BC 548)
- 12) Relay (220AC/ 12vDc)
- 13) Voltage regulator (LM7805 and LM 8712)
- 14) Liquid Crystal Display
- 15) Electric heating Element
- 16) Single phase Motor
- 17) Thermostat
- 18) Diode (light emitting diode)

On the other hand, simulation software used were Proteus and Arduino IDE: (Arduino Integrated Development Environment)

**B. Method**

The research used proteus software to design and simulate the circuit. The control program was written in Arduino IDE: (Arduino Integrated Development Environment).

The block diagram in figure 1 below shows the various units of the garri frying machine and their interconnection.

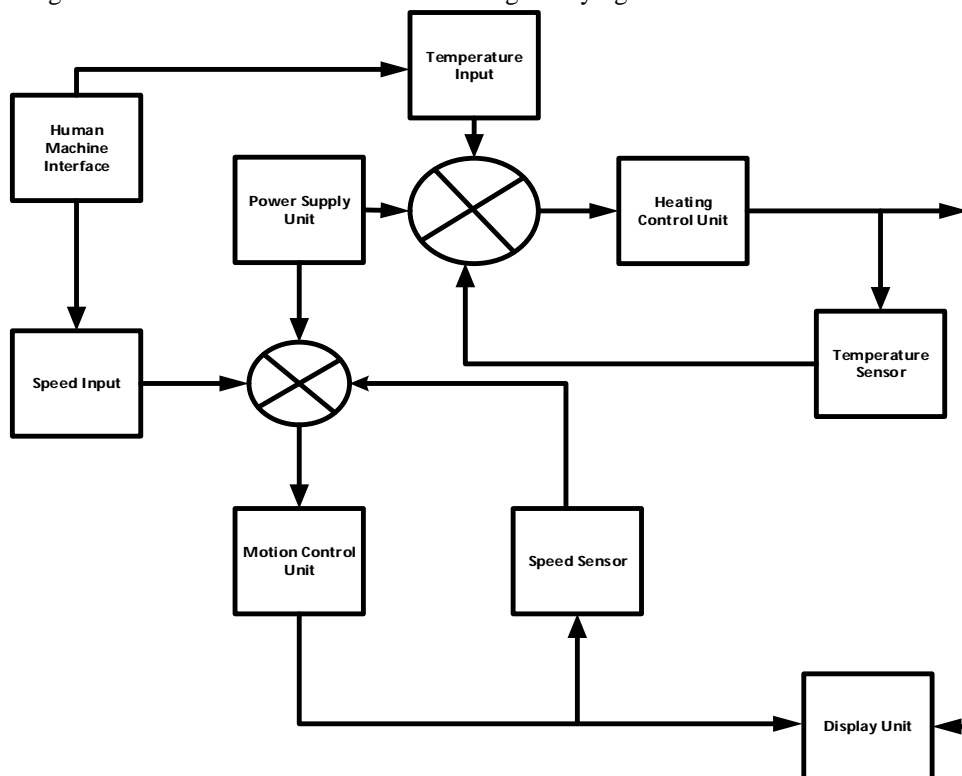

Figure 1: Block diagram model for the proposed garri frying machine with user-defined temperature regulation and motion control system

The above components listed in the material section were connected in proteus simulation environment using the circuit diagram in figure 2.

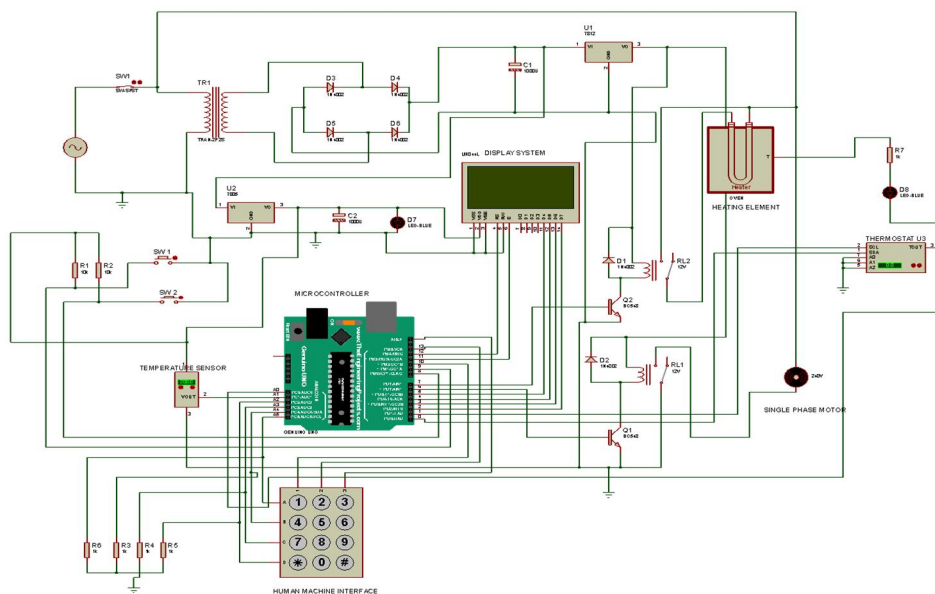

Figure 2: Circuit diagram of Garri Frying Machine with User-defined Temperature Regulation and Motion Control System

#### IV. DESIGN SPECIFICATIONS

Table I and table II show the system specification and the motor parameters for the designed garri frying machine.

Table 1: Design Specifications

S/no	Component	Circuit Label	Function in the circuit	Specifications/Model applicable
1.	Power Supply	AC	General power supply to the circuit	220V
2.	Switch	SW1	Circuit input control switch	SPST
3.	Transformer	TR1	Voltage Step-down transformer	220/150V AC
4	Diode	D3, D4 , D5, D6	Rectifier diodes	IN4001
5.	Diode	D2, D1	Relay drivers	IN4001
6.	Resistor	R1,R2	Current dividers	1k
7.	Resistor	R3,R4, R6,R5	Pull-up resistor	1K
8.	Resistor	R7	Limiting resistor	1K
9.	Temperature sensor	LM35	Temperature detecting system	0-200 degree C
10.	Switch	SW1 , SW2	Sensor control switch	Push button Switch
11.	Diode	D7, D8	System status indicators	Light Emitting Diode -blue colour
12.	Capacitor	C1, C2	Removal of Ac ripple from rectified voltage	1000uf
13.	Microcontroller	GEN UNO UNO	System controller	Arduino Uno
14.	Keypad	HMI	Human input platform to the system, Manual stoppage of the system	Human Machine Interface
15.	Transistor	Q1, Q2	Relay Switching	BC 548
16.	Relay	RL1 , RL2	AC and DC switching system for heater, motor and thermostat	220AC/ 12vDc
17.	Voltage regulator	U1	Dc 5v supply to microcontroller	LM7805
18.	Voltage regulator	U2	Dc 12v supply to relay contact coil	LM 8712
19.	Liquid Crystal Display	LM044L	Voltage level display	6X4 LCD
20.	Electric heater	Oven	Electric heating source	220v, 10A, 1800w
21.	Motor	Single phase A.C. Induction Motor	Rotating machine that turns the garri to dry	220v; 12A ,2kw
22.	Thermostat		Temperature automatic regulatory device	Temperature (measurements): Range: 0°C to 200°C (± 0.1°C) Temperature (Set Point): Range: 5°C to 30°C (± 0.5°C) Units: °C only

Table II. Design parameter for the single phase AC Induction motor

Parameter	Model/Evaluation
Rated voltage	$v = 220\text{volts}$
Rated current	$i = 12A$
Speed	$N = 1500\text{rpm}$
Weight of garri	$Wg = 50N$
Weight of connecting shaft	$Ws = 30N$
Radius of frying pan	$R = 0.15m$
Motor torque	$T = (Wg + Ws)R = (50 + 30)0.15 = 12Nm$
Motor Power	$Pm = \frac{2\pi NT}{60} = \frac{2 \times \pi \times 1500 \times 12}{60}$ $Pm = 1884 \approx 2000\text{watts} = 2kw; \text{considering losses [6]}$

## V. RESULTS AND DISCUSSION

### A. Results Presentation

The following results were obtained from the simulation.

Table III: Heater control system response

Temperature (°C)	Duration(Seconds)	Voltage(V)	Current(A)	Power (W)
60	60	220	1.6	352
65	60	220	2.5	550
70	60	220	3.3	726
75	60	220	4.1	902
80	60	220	4.8	1056
85	60	220	5.3	1166
90	60	220	5.6	1232
150	60	220	6	1320
160	60	220	7.1	1562
170	60	220	8.8	1936

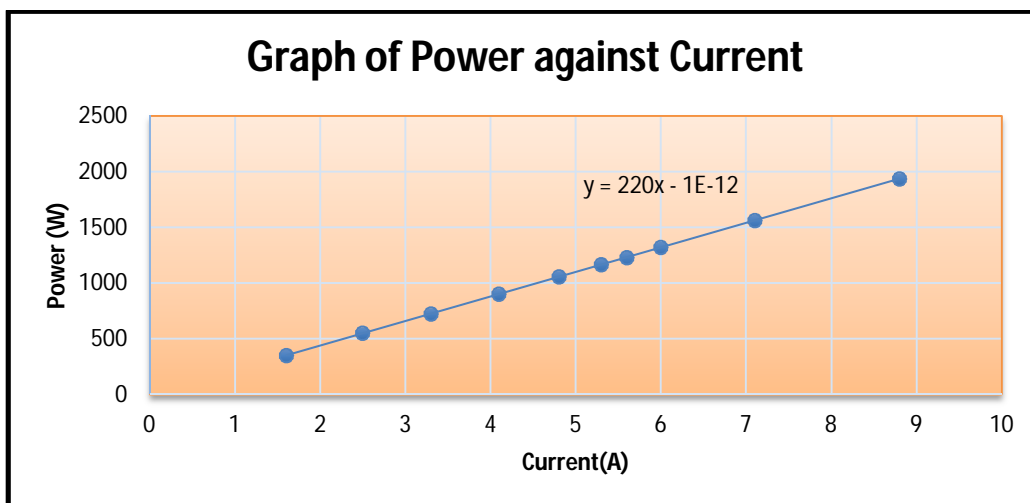

Figure 3 Heater power versus current

Table IV: Motor Control System Response

Speed (rpm)	Duration (seconds)	Voltage (V)	Current (A)	Power (W)
100	60	220	0.714	125.720
300	60	220	2.143	377.160
500	60	220	3.572	628.600
700	60	220	5.000	880.040
900	60	220	6.429	1131.480
1100	60	220	7.858	1382.920
1200	60	220	8.572	1508.640
1500	60	220	10.715	1885.800

**B. Discussion**

Table III shows the heater control system response. The power consumed by the heater unit increased with increase in input temperature. The implication of this result is that there is a positive change in current drawn by the heater unit as a result of increase in level of input temperature from the Human-Machine Interface. This confirms the ability of the design to initiate and control heat generation through the use of microcontroller based programming. This is collaborated by figure 3.

One the other hand, table IV shows the motor control system response. The power consumed by the driving unit increased with increase in input speed. This implies that the control system was able to accept speed levels from the Human-Machine Interface as input used to generate corresponding power in the motor circuit to drive the motor at the input speed. This confirms an effective motion control in the driving unit by the use of hardware programming.

**VI. CONCLUSIONS**

Based on the results obtained from the simulations, the heating control unit designed for the garri frying machine in this research was able to use temperature level as an input from the Human-Machine Interface to determine the current drawn by the heating element in the heater. This makes it possible for users of the proposed system to define the quantity of heat to be generated by the heating unit at any time in the garri frying process by the use of numerical input of temperature in degree Celsius. Also, the motion control unit designed for the system was effective as users of the system can determine the speed of the driving unit of the garri frying machine by numerical input from the Human-Machine Interface in speed mode. Further research is recommended in the physical implementation of the design.

**VII. ACKNOWLEDGMENT**

We acknowledge the Almighty God for the inspiration to conceive the design of this system. Our spouses and children were of immense moral support during the research period.

**REFERENCES**

- [1] G. Flibert, K. Some, D. Kabore, H. Sawadogo-Lingani, Y. Traore, and A. Savadogo, "Origins, production, and utilization of cassava in Burkina Faso, a contribution of a neglected crop household food security," *Food Science & Nutrition*, Jan. 2016.
- [2] C. Balagopalan, (2002). Cassava utilization in food, feed and industry. Cassava: Biology, production and utilization, 301-318.
- [3] C.S. Onyemauwa, "Analysis of Household Consumption of Cassava Products in Ohaozara, Ebonyi State, Southeast Nigeria," 26-Aug-2020. [Online]. Available: [futospace.futo.edu.ng/handle/123456789/3293](https://futospace.futo.edu.ng/handle/123456789/3293).
- [4] A.Kolawole, (2017). PROCESSING OF CASSAVA INTO GARI AND HIGH QUALITY CASSAVA FLOUR IN NIGERIA. 10.13140/RG.2.2.22427.36640.
- [5] R.O. Chima, and F.O. Odo, "Analysis of Garri Frying Machine Manufacturing in Nigeria: Design Innovation - Journal," *Journal*, 26-Aug-2020. [Online]. Available: [astesj.com/v03/i06/p48/](https://astesj.com/v03/i06/p48/).
- [6] B. O. Akinnuli, C.O.Osueke, S.O. Ikubanni, O.O. Agboola, and A.A. Adediran "Design concepts towards electric powered gari frying machine,," *International Journal of Scientific and Engineering Research*, vol. 6, no. 5, pp. 1043–1050, Jan. 2015.
- [7] O. O. Ajayi, O. J. Olukunle, and M. Dauda, "Performance evaluation of an automated gari fryer," *The International Journal of Engineering and Science*, vol. 3, no. 2, pp. 39–46, Jan. 2014.
- [8] T. M. A. Olayanju, C. E. Okonkwo, J. O. Ojediran, S. A. Alake, A. A. Okunola, E. A. Alhassan, E. O. Idahosa, "Development of an improved gari fryer," *International Journal of Mechanical Engineering and Technology*, vol. 9, no. 11, pp. 769–778, 2018.
- [9] G. A. Ikechukwu, and A. I. V. Maduabum, "Improved mechanized gari frying technology for sustainable economic development in Nigeria". In *Proceedings of the International Multi-Conference of Engineers and Computer Scientists (Vol. 2)*. (2012).
- [10] P. O. Ajewole and E. O. Adeosun, "DESIGN ANALYSIS OF A CASSAVA MASH ROASTER," *GSJ*, vol. 6, no. 1, p. 223, Jan. 2018.
- [11] O. A. Ali, A. Saturday, O. E. Nathaniel, A. A. Ifeanyi, E. G. Ajagun, & K. Oluwatomi, "Gelatinization and Frying Temperatures Stabilization of a 'Garri' Frying Machine Using a PID Microcontroller-Matlab Simulink", *Scholars Journal of Engineering and Technology (SJET)*, vol. 5, no. 6, pp. 295-306, 2017.



10.22214/IJRASET



45.98



IMPACT FACTOR:  
7.129



IMPACT FACTOR:  
7.429



# INTERNATIONAL JOURNAL FOR RESEARCH

IN APPLIED SCIENCE & ENGINEERING TECHNOLOGY

Call : 08813907089  (24\*7 Support on Whatsapp)