



IJRASET

International Journal For Research in
Applied Science and Engineering Technology



INTERNATIONAL JOURNAL FOR RESEARCH

IN APPLIED SCIENCE & ENGINEERING TECHNOLOGY

Volume: 8 Issue: XI Month of publication: November 2020

DOI: <https://doi.org/10.22214/ijraset.2020.32111>

www.ijraset.com

Call:  08813907089

E-mail ID: ijraset@gmail.com

Self-Powered Energy Producing System

Dhruv Sharma

B. Tech ECE

Abstract: *Since the 17th century the human race is in the pursuit to reduce the human effort in the industrial works and produce an efficient system that can achieve this. The first glorified milestone of this chase was the steam engine which later turned out to be the most important catalyst of the industrial revolution in later 17th century.*

Since then the world of engines, motors, generators and other power producing equipment's has taken a giant leap and has now led to supercars getting driven by electricity and no internal combustion engine.

The idea of this self-run power engine can prove to be a path changer in terms of sustained energy with reduced resources and labour. The apparatus used in this system comprises of antecedental devices which are evidently used in other power machineries as well so we are not using any self-developed machine in this system.

Keywords: *Self powered, Power, AC generator, Electronics pressure regulator.*

I. INTRODUCTION

Due to the rise of industries, manufacturing units and the ever-increasing electricity demand there has been a steep decline in the availability of natural resources and scientists believe that if we exploit natural resources by the current rate we will run out of resources by the year 2050 and at that point it will be very arduous for the civilization to acclimatize to something new. Ergo we have to start finding the alternatives to these natural resources, some discoveries have already been done and are used such as tidal power, solar powered machines, wind energy to create electricity etc.

But no alternative has provided the solution to compensate or proxy the resources getting utilized, to harvest power in electrification units, generation stations and industrial units. Our system caters to that problem it is self-powering system that eradicates the need for constant power requirement to keep the system in a working state, in essence we are distributing the power developed amid the output device and the input energy unit and our system is producing electricity as the end product which can be used for innumerable operations such as energy generation, electricity mobilization etc.

II. LITERATURE SURVEY

Many kinds of researches have been done in the field of convertible energy sources, energy reuse, renewable energy and many ideas have been developed on the framework of utilizing non-conventional and sustainable sources of energy to equipose our daily needs of electricity and other resources without jeopardizing the resources which can be further utilized for some other causes.

Some systems are employing PLC and SCADA to reduce the energy wastage and create an ease of controlling the machine operation, as an example Indian railway has employed SCADA in its electrification units to save the excess voltage flowing in the OHE's which was wasted back when signalling or strowger switch was employed for electrification.

Railways is also employing the technique of regenerative braking to save some voltage/energy. Many papers have also been written on similar premise but they don't tackle the issues of making the system running completely resourceless.

One paper that I came across while researching discussed the idea of producing electricity by means of using many electronic circuits which was also one time powered but no proper flow of energy or its utilization was elucidated.

Another paper inculcated the idea of a system that operated a machine which gave free energy and it used AI and electronic sensors to measure the required parameters but it was just the system no attached ancillary apparatus was put to used. So, by an extensive research I found out that no system deals with the combined problem statement solution of energy saving, easy conversion, one time driving and illustrating the entire operational regime and that is the reason why I went ahead with this idea.

III. METHODOLOGY

As mentioned earlier our system has to be powered only once to start the machine cycle and afterwards no resources will be required, the machine can be brought to a halt by an electronic device called as electronic pressure regulator, this device is capable of reducing or stopping the energy from the turbines that that is going in the input unit and the entire system will come to a cease down.

This machine consists of a pressure dispenser which will give the pressure for the turbines to operate, there is another set of turbines that will deliver the power through a pneumatic rotor to the pressure dispenser to create a cycle. Most of the energy is provided to a torque-based AC generator which actually converts the already present mechanical energy into electrical energy in the form of AC Current.

The pressure initiated from the pressure dispenser goes into the power system and the first set of turbine starts running and the power is provided to a torque-based generator and also the power is transferred via a serpentine belt to the second set of turbines which provides power to a pneumatic rotor that finally operates the pressure dispenser and another cycle is initiated and this trail continues with generator providing us with AC electric energy and machine self-powering itself.

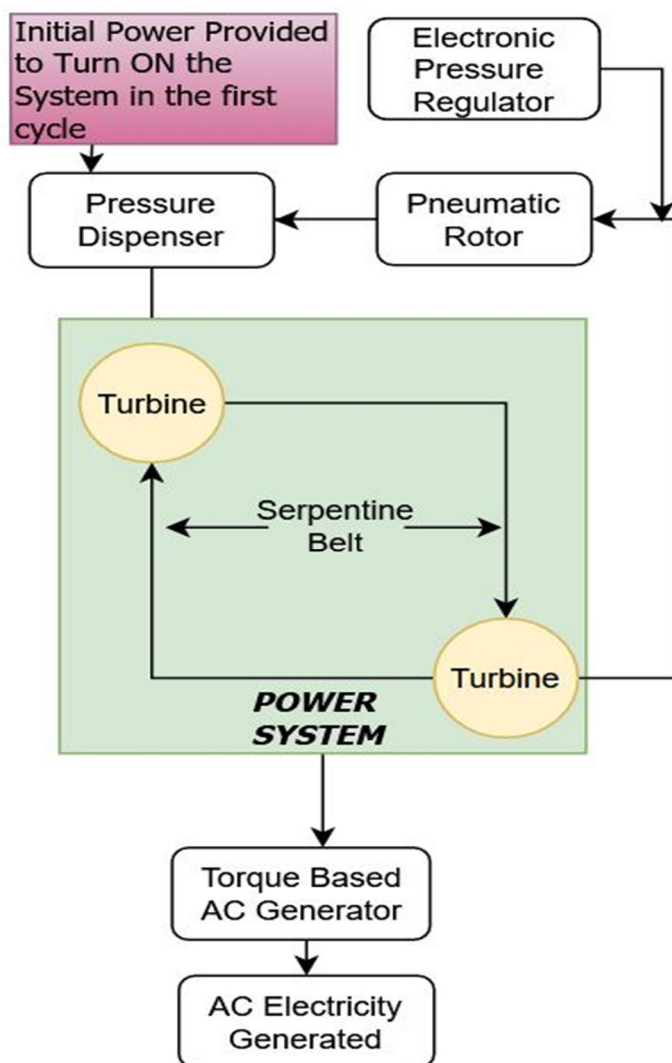

Fig 1. Block Diagram depicting the functioning and components of the system

The electronic pressure regulator is a device that can cut off or decrease the pressure using the principles of control system as it's a servocontrol system, to explain briefly these are mechanical devices which use the concept of feedback and depending on that and the data entered the functioning changes.

In electronic power regulator the controller sets a threshold and using feedback control starts measuring the error which is nothing but change in the air supply and thus it can be used for discontinuing the working of the system the operator can simply decrease the value of air flow to a bare minimum which stops our system as this machine just increases its internal error which finally halts it as the pressure dispenser of our system stops. A functional diagram shown below depicts the internal structure of an electronic pressure regulator.

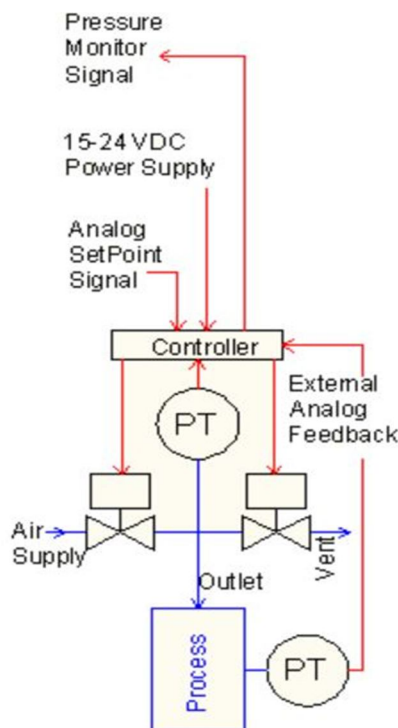

Fig 2 Block Diagram of the electronic pressure regulator describing the working process

IV. MATHEMATICAL ANALYSIS

The power generated from a device that employs air pressure as an operational force is given as: $E' = p \cdot v$ Where E' = Power, P = Pressure and V = Flow rate. So, if we want to create a power of let's assume 1200W from the generator then the equation will be $E' = p \cdot v$. We assumed the power to be 1200 W and take the pressure to be 100 atm /pa so, $1200 = 100 \cdot v$ Therefore,

$$v = 12 \text{ pa/sec}$$

So, if we Provide the pressure of 100 atm/sec with a flow rate of 12 pa/sec or 12 sccm (SI unit of gaseous flow rate i.e. standard cubic centimetre per second) we can generate the above-mentioned power of 1200W or even more by increase the pressure or flow rate.

V. APPLICATION

- A. This system can be used in industries, factories and power generation units.
- B. Can be used for the production of green energy as no fuel or pollutant is emitted from the system.
- C. Can be used for electrification of bigger automobiles.
- D. Used as an extension system in wind mill farms for rapid electricity production.

VI. RESULTS AND CONCLUSION

Through this project I am trying to make a system that does not need constant power supply to remain operation but powering only once for the initial start will be

sufficient as the system will power itself once it's in the locked operational cycle and the switching Off is mechanised through an electronic pressure regulator. The system can be further modified by changing the torque-based generator i.e. the output device of this system to any other apparatus that leads to the desired output energy as per the user's requirement.

I improvised the concept of adding a torque-based generator but the energy that we are receiving from the system can be utilized elsewhere as well. There are some factors that can alter with the operation of this system and those are:

- A. Unbalanced parameters of the apparatus used in constructing the system.
- B. Irregularities in construction and usage.
- C. Using system on different ratings and different pressure levels.



VII. FUTURE SCOPE

- A. The main hinderance of this system functioning is that the torque-based AC generators have an efficiency of around 50% so around half of the power will be wasted in the conversion process of generator assuming if the user is using it in this system so a better generator can be designed and used for increased efficiency.
- B. This system will be bulky in size so we can reduce the size which will increase this systems accessibility.
- C. To make this system even more efficient we can programme it using machine learning and AI technology used nowadays.

REFERENCES

- [1] https://www.researchgate.net/publication/317223048_Power_generation_using_gear_setup_with_dynamo
- [2] https://www.researchgate.net/publication/307572660_Efficient_PID_controller_tuning_method_selection_to_be_used_in_excitation_system_of_brushless_synchronous_generator
- [3] Dr. C Anil Kumar, Chetan Kumar S, Amul, Santosh Nayak, Manjunath "SELF POWER GENERATION SYSTEM FOR AUTOMOBILES" IRJET 2020.
- [4] https://www.researchgate.net/publication/24442893_Torque_generation_and_elastic_power_transmission_in_the_rotary_FOF1-ATPase



10.22214/IJRASET



45.98



IMPACT FACTOR:
7.129



IMPACT FACTOR:
7.429



INTERNATIONAL JOURNAL FOR RESEARCH

IN APPLIED SCIENCE & ENGINEERING TECHNOLOGY

Call : 08813907089  (24*7 Support on Whatsapp)