



IJRASET

International Journal For Research in
Applied Science and Engineering Technology



INTERNATIONAL JOURNAL FOR RESEARCH

IN APPLIED SCIENCE & ENGINEERING TECHNOLOGY

Volume: 8 Issue: XI Month of publication: November 2020

DOI: <https://doi.org/10.22214/ijraset.2020.32249>

www.ijraset.com

Call:  08813907089

E-mail ID: ijraset@gmail.com

The Floor Cleaning Robot Design and Operation

Prof. P. S. Barve¹, Prof. M. K. Mendhe², Aatish Shahale³, Abhishek Ambare⁴, Anay Mukte⁵

^{1,2}Assistant Professor Department of Mechanical Engineering YCCE Nagpur

^{3,4,5}Students of Department of Mechanical Engineering YCCE Nagpur

Abstract: Today, society is moving from joint family towards nuclear family. This is mainly due to the jobs where a family consisting of parents and their children (one or more) have to settle to a different location other than the family's main belonging. Also, old people have to leave on their own after their children have relocated due to various reasons like job location. In nuclear family, it might happen that both parents are working. This creates the problem that how to manage the work, children and house. There might not be time for cleaning house as it requires a lot of time. On the other hand, old people living in house may face difficulty to clean their house due to their health conditions. Also, maid cannot be there for the whole time to keep the house clean. This problem can be overcome by designing a floor cleaning robot which can clean and mop the floor by just pressing a button as an automatic robot or controlling it manually with the help a mobile application. The design of the floor cleaning robot will be such that it will clean the whole area on pressing a button and can clean manually only a specified area to save time, battery, water, etc.

Keywords: Floor Cleaning Robot, Clean And Mop The Floor, Automatic Robot

I. INTRODUCTION

As the World is moving forward, many technological advancements are taking place each and every day. Among them, Robots are also evolving at a rapid pace. Robots are used in almost each domain that can be found in our surrounding. Among them, use of robotic devices in day to day household working is also increasing day by day. Above all other devices, Floor Cleaning Robots are the need of the hour. There are various Floor Cleaning Devices available in the market. At present, the company "iRobot" is dominating the market of Robotic Floor Cleaners. If we consider the available robotic floor cleaning devices, most of them are very costly pricing more than Rs. 20000/- in Indian market which is very costly device to be used in India. Furthermore, most of them use vacuum technology to clean the floor. When using vacuum to clean the robot, many stains caused by food items cannot be vacuumed once they dry out. This is the basic limitation of vacuum based Floor Cleaning Robot. Beside vacuum based robots, the other variants available are wet mopping robots which first wet the floor using water then scrub the floor and then vacuum the dirty water over the floor. To think wet mopping is the best way to clean the floor as it covers various aspects of cleaning. When we talk about existing Wet Mopping Robots they first have to be filled with clean water then place it on the floor for cleaning and after the cleaning is over the dirty water which is collected by the robot using vacuum has to be removed from a different water container. This sequence of operation is less efficient as people have to handle water two times which includes handling of dirty water. Also, the robot has to have two separate tanks to store two different types of water which increases the overall volume of the robot. Use of vacuum increases the power consumption of the robot. If we overlook features and working of different existing Floor Cleaning Robots, they are still inefficient and are overpriced for the features they offer. To overcome these issues, we have decided to design a Robot which does not contain vacuum and has only one water tank. This will reduce the volume of the robot and will consume less power as compared to the existing devices. Removing vacuum also affect the price of the robot. We will also be using low cost and low power components to reduce the cost of robot and make it more efficient. Having only one water tank, it will be less messy to operate. Also, people do not have to handle the dirty water.

II. COMPONENTS

There are a variety of electronic components available in the market which can be used to manufacture the robot. We have used a selected number of components which helped us to design and manufacture the Floor Cleaning Robot. The components we included are as follows:-

- 1) **Arduino Mega 2560:** Each robot must have a brain. We will be using Arduino Mega as the brain of our robot. The main feature of Arduino Mega is that it provides both 16 analog pins, 54 digital I/O pins, has inbuilt 16 MHz clock, can be programmed as per need and has 256 KB of flash memory.
- 2) **12v DC Motors:** We have used geared 12v DC motors as they provides high torque and can be interfaced easily with the L293D Motor Driver.
- 3) **High Speed Fans:** We have used 12v high speed fans to get maximum air speed that can be used to dry the floor water.

- 4) *Ultrasonic Sensor:* We have used HC-SR04 Ultrasonic Sensor module to detect obstacles that may come in front of the robot.
- 5) *L293D Motor Driver:* We have used L293D Motor Driver module to control the DC motors which moves the robot.
- 6) *HC-05 Bluetooth Module:* To connect the robot with mobile application for controlling its various operations (see Mode of Operation), we have used HC-05 Bluetooth Module.
- 7) *Battery:* Battery is the only power supply we can have on our robot because using wires to supply power can restrict the movement of robot. We have selected 12v battery as almost all the components we are using on our robot have input voltage specification of 12v(Arduino boards have an operating voltage of 5v but have input voltage range of 6v-20v out of which 12v is the most preferred Arduino input voltage).

III.DESIGN

The design of the Floor Cleaning Robot comprises of first designing the sequence of operation which include all the components to work in sync. The program to run the robot will be designed according to the sequence of operation.

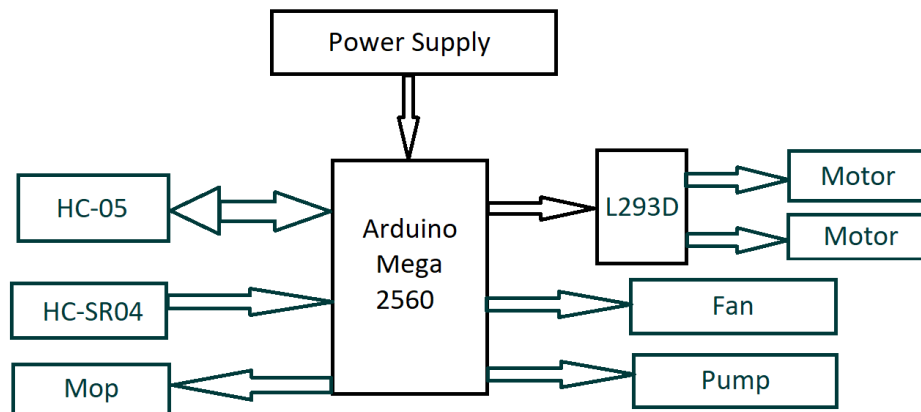

Figure 1. Block diagram/ Sequence of Operation

The design of the robot is as follows:-

- 1) The robot have is a 4 wheel robot with a strong light weight chassis. Front two wheels are dead wheels which means they do not have power to control them as they do not have motor. Rear wheels have motors to drive the wheels. These wheels are used to control the movement of the robot in any direction.
- 2) On the top, there is water tank, pump and controller/ Arduino board with different components like motor driver, Bluetooth module, etc. along with battery to power the robot. The top front side of the robot have ultrasonic sensors to detect the obstacles in front of the robot.
- 3) In the lower side, the robot have spray nozzle fixed at the front of the robot. This is designed in such a way that it uses minimum amount of water which is required to clean the floor and spray the water evenly over a specific area. The spray is operated be a pump. The pump takes the water from the water tank.
- 4) Just behind spray nozzle, there are 2 mops placed side by side and rotates in opposite directions. The mops are controlled by a high torque motor which is controlled by a motor driver.
- 5) Towards the end of the robot we have high speed fans which will dry up the remaining water on the floor after the mopping is complete. Drying the floor is a crucial task as any amount of water left on the floor can result in any accident such as someone slipping over it.
- 6) Then we have a program written, compiled and uploaded on the Arduino Mega board using Arduino IDE (an open source software to program Arduino boards).
- 7) We have used Arduino Bluetooth Controller android app to control the robot. This app have a feature of configuring any button to send a particular command to the Arduino board. We have configured the buttons on the app to perform a specific tasks. Following are the buttons and their respective works:-

- a) *Up-Arrow* : - To move the robot forward
- b) *Down-Arrow* : - To move the robot backward
- c) *Right-Arrow* : - To move the robot right
- d) *Left-Arrow* : - To move the robot left
- e) *Select-Button*: - To start the cleaning operation irrespective of the movement of robot
- f) *Start-Button*: - To start the Auto-Clean Mode (see Mode of Operations).

The robot is programmed to perform various operations. These operations can be selected by user to get a particular work done.

IV. MODE OF OPERATION

The Floor Cleaning Robot have a variety of operating modes a user can use. They are discussed as follows:-

- 1) *Free-Run Mode*: The user can move the robot using the mobile application by tapping the direction keys just as we drive a remote control car. Using this mode we can place the robot at any place we want it to be.
- 2) *Manual-Clean Mode*: In this mode, we first take the robot to the location where we want to clean, then we press Start-Clean Button on the app and control the movement of the robot. This mode is useful to clean only a patch of floor where cleaning is required. This will reduce the usage of excess water, will consume less power and time will also be saved.
- 3) *Auto-Clean Mode*: There is Auto-Clean button on the android app. Once we press the button, the robot will start cleaning the floor from the position it is standing. It will keep moving forward while cleaning the floor. This mode is used to clean the whole room.

V. CONCLUSIONS

The Floor Cleaning Robot developed is a new concept in floor cleaning area. When using fans to dry the wet floor, the robot does its job properly except the fan generate a lot of noise during operation. Also, the robot can only clean the floor and not vacuum the litter on the floor. Even if our robot lacks the ability to vacuum the floor, the cleaning ability is better to that of vacuum based robots. The power consumption is also low. When using Manual-Clean Mode, there is a lot of time, power and water saving. Also, it is very fun to operate in Manual-Clean and Free-Run Mode. With improvements, this robot can give a tough competition with respect to price and performance to the products available in the market

VI. ACKNOWLEDGMENT

First and foremost, we would like to thank Principal Dr U P Waghe for blessing us with enthusiasm, courage, knowledge and energy to help us finish our paper work. We are thankful and would like to express our sincere gratitude for our HOD Dr S S Chaudhari for his guidance, support and continuous encouragement in making this project possible. His guidance from initial to final level enabled us to achieve our objective of paper work.

Our sincere thanks to all our colleague who helped us in many ways, gave valuable advises and made our journey easy.

REFERENCES

- [1] S Monika, K Aruna Manjusha, S V S Prasad, B.Naresh, Design and Implementation of Smart Floor Cleaning Robot using Android App, International Journal of Innovative Technology and Exploring Engineering (IJITEE), 2019, 8 (4S2), p.250r
- [2] Manya Jain, Pankaj Singh Rawat, Assist. Prof. Jyoti Morbale, Automatic Floor Cleaner, International Research Journal of Engineering and Technology (IRJET), 2017, 04 (04), p.303
- [3] A. Vimala, S.Manikandan, T.S.Aravinth, S. Birundha Devi, S. Sathiya Gopika, Microcontroller Based Floor Cleaning Robot, International Journal of Innovative Technology and Exploring Engineering (IJITEE), 2019, 8 (4S), p.446
- [4] P.S. Adithya1, R. Tejas, V. Sai Varun, B.N. Prashanth, Design and Development of Automatic Cleaning and Mopping Robot, In IOP Conference Series: Materials Science and Engineering, Bengaluru, India, 16-18 August 2018, doi:10.1088/1757-899X/577/1/012126



10.22214/IJRASET



45.98



IMPACT FACTOR:
7.129



IMPACT FACTOR:
7.429



INTERNATIONAL JOURNAL FOR RESEARCH

IN APPLIED SCIENCE & ENGINEERING TECHNOLOGY

Call : 08813907089  (24*7 Support on Whatsapp)