



IJRASET

International Journal For Research in
Applied Science and Engineering Technology



INTERNATIONAL JOURNAL FOR RESEARCH

IN APPLIED SCIENCE & ENGINEERING TECHNOLOGY

Volume: 8 Issue: XI Month of publication: November 2020

DOI: <https://doi.org/10.22214/ijraset.2020.32322>

www.ijraset.com

Call:  08813907089

E-mail ID: ijraset@gmail.com

Study on Behavior of Dry Joint in Precast Concrete Segmental Bridge with Different Shaped Keys

Swetha V. U.¹, Anu Retnakar²

¹P. G. Student, ²Assistant Professor, Department of Civil Engineering, Universal Engineering College, Thrissur, India

Abstract: The precast concrete segmental bridges (PCSBs) are the most preferred bridge in modern bridge construction. The structural behavior of precast concrete segmental bridge is based on the behavior of joints. The joints are formed by interlocking of shear keys in precast concrete segments. The dry joint is a highly recommended joint in PCSBs for more safety and accelerated construction. The aim of this study is to understand the effect of shape of shear key on the behavior of dry joint of PCSBs. Single keyed dry joint with six key shapes are considered for the study. The joint performance is evaluated by considering the ultimate load of the joint and also by the pressure developed in contact region and total deformation in the key region at the time of ultimate load. Analytical study is performed using ANSYS Workbench. The performance of single keyed dry joint specimens is studied under displacement controlled vertical loading and constant horizontal confining pressure.

Keywords: Dry Joint, Precast Concrete Segmental Bridges, Shear Keys, Ultimate Load of Joint.

I. INTRODUCTION

In present bridge construction the precast concrete segmental bridges (PCSBs) are most preferred due to its durability and it makes the longer bridge construction easier and economic. In this type segmental bridge the girder is made by the assembly of precast concrete box girder segments. So the superstructure of PCSBs contains joints. The joints are formed by the interlocking of small projections called shear keys in one precast concrete segment with depressions in the adjacent segment. This joint can be provided with or without infill material. The joint without any infill material is called a dry joint. The dry joint is preferred in PCSBs to make bridge construction more accelerated and for safety. The joints have high relevance in controlling the structural behavior of PCSBs. Through this joint the compression and the shear forces are transmitted. The joint in PCSBs is subjected to horizontal prestressing force and shear force in vertical plane. The present using shape of shear key is bevelled rectangle shape. This study is an investigation to understand the effect of shape of shear key in the behavior of single keyed dry joint in precast concrete segmental bridge. This study also provides an attempt to derive a dry joint with better joint performance.

II. ANALYTICAL INVESTIGATION

The analytical study is conducted on single keyed dry joint with different key shapes. The shapes of key considered for the study are bevelled rectangle shape (standard key shape), bevelled square shape, bevelled triangle shape, round shape, slot shape and rectangle shape.

A. Details of Geometry

The details of dimensions of dry joint are shown in Fig. 1. The dry joint specimen consists of two parts. The part with shear key is called as female part and the other part is male part. The length, width and height of each joint part are the same. For each joint the shape of shear key and height of area of contact is changed. The height of contact area is consists of 50 mm length additional to vertical height of each key at top and bottom. From the formulas related to the shear strength of PCSBs joint the base area of key has a significant role in shear strength. The base area of key is approximated to 25000 mm². The parts are modeled and assembled in Fusion 360 Modeling software. The files of geometry in .iges format are imported to ANSYS Workbench for the analysis. The dimensions of keys are shown in Fig. 2 to Fig. 3.

Table 1. Dimensions of Part of the Joint

Length of part	Width of part	Height of part	Depth of key
350 mm	250 mm	420 mm	50 mm

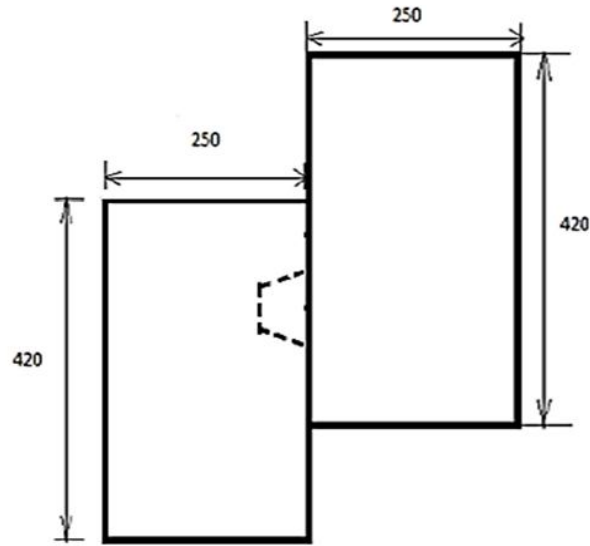

Fig. 1 Typical Dimensions of Joint in mm

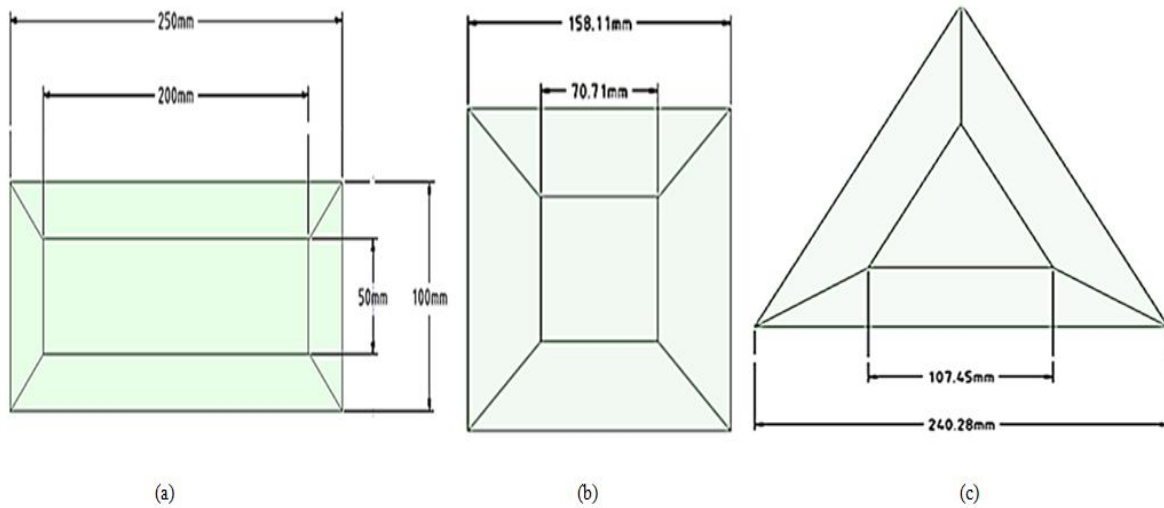

Fig. 2 Dimensions of (a) Bevelled Rectangle Key (b) Bevelled Square Key (c) Bevelled Triangle Key in mm

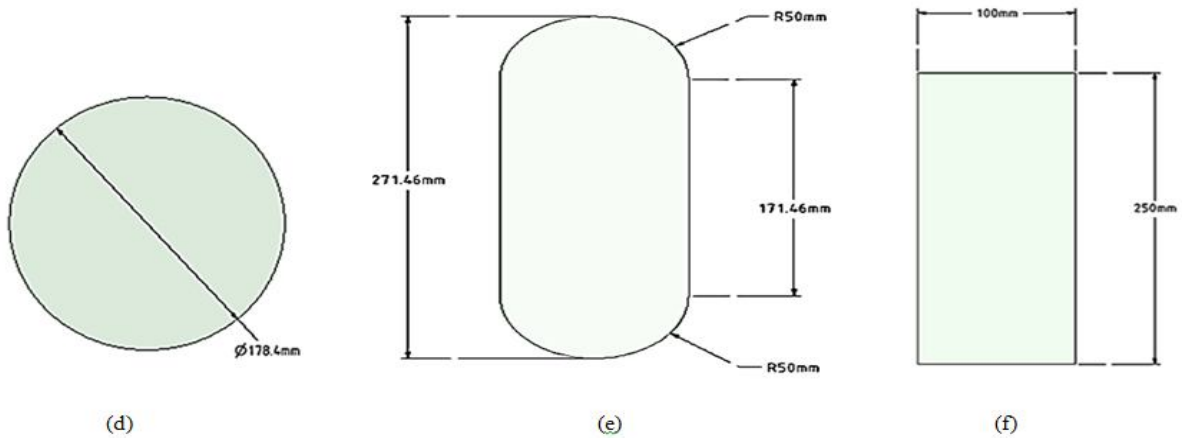

Fig. 3 Dimensions of (d) Round Key (e) Slot Key (f) Rectangle Key in mm

B. Material Properties

The parts of the joint are made of concrete. Concrete with compressive strength of cube 30 N/mm² is used in this work. The properties of concrete used are given in Table 2. The solid 65 element is used for modeling the concrete. Solid 65 element in Ansys is a three dimensional element used to model solids, especially concrete. It represents the concrete with or without reinforcement. The stress strain curve of concrete is shown in Fig. 4.

Table 2. Material Properties of Concrete

Material property	Value
Young's modulus	29250 N/mm ²
Poisson's ratio	0.2
Compressive strength	30 N/mm ²
Tensile strength	3 N/mm ²
Density	2400 kg/m ³
Open shear transfer coefficient	0.3
Closed shear transfer coefficient	0.8

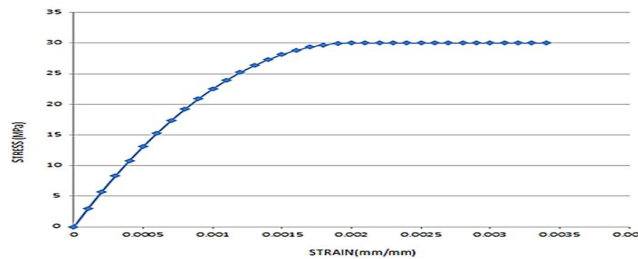

Fig. 4 Stress Strain Curve of Concrete

C. Meshing , Loads and Boundary Condition

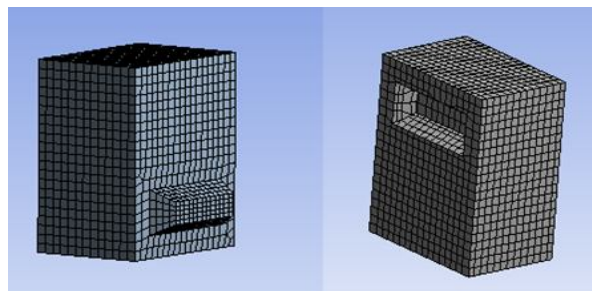

Fig. 5 Typical Meshing of Female and Male Parts of Joint

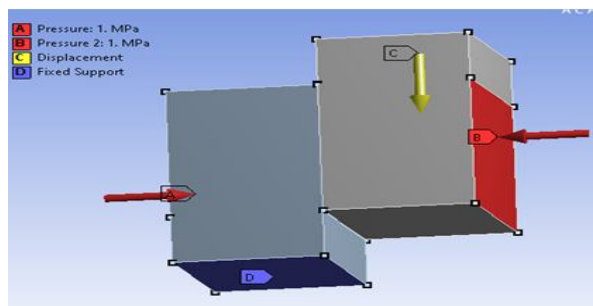

Fig. 6 Loading and Boundary Condition at Joint

To study analytically the behavior of dry joint the static structural analysis is conducted in ANSYS Workbench. For the analysis bottom of the male part is fixed and the load is applied through the female part in which the shear key is present. The displacement controlled vertical loading with a rate of 0.005 mm/s is applied on the top surface of the female part. The constant horizontal confining pressure of 1 MPa is provided in both sides of the joint specimen. The contact is defined before the loading. The frictional contact with frictional coefficient 1.1 is taken.

III. RESULTS AND DISCUSSION

In this study the behavior of dry joint is evaluated by the ultimate load and also by the pressure in contact region and total deformation in the key region at the time of ultimate load.

A. Ultimate Load

The ultimate load of the each joint is obtained by the shear vs. slip curve. For this graph the shear in the face situated at the base of shear key is taken. The slip is the vertical displacement of the loading surface.

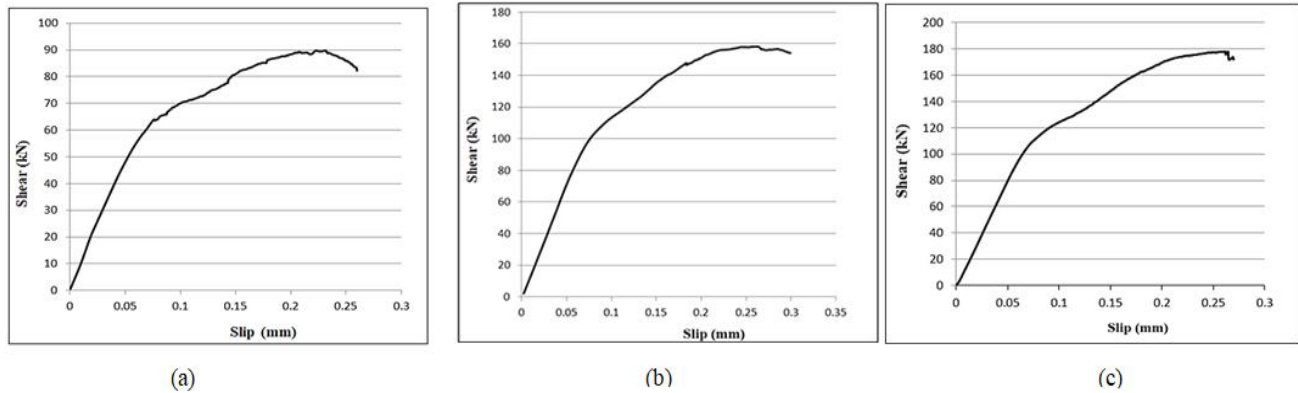

Fig. 7 Shear vs. Slip Graph of (a) Bevelled Rectangle Key Dry Joint (b) Bevelled Square Key Dry Joint (c) Bevelled Triangle Key Dry Joint

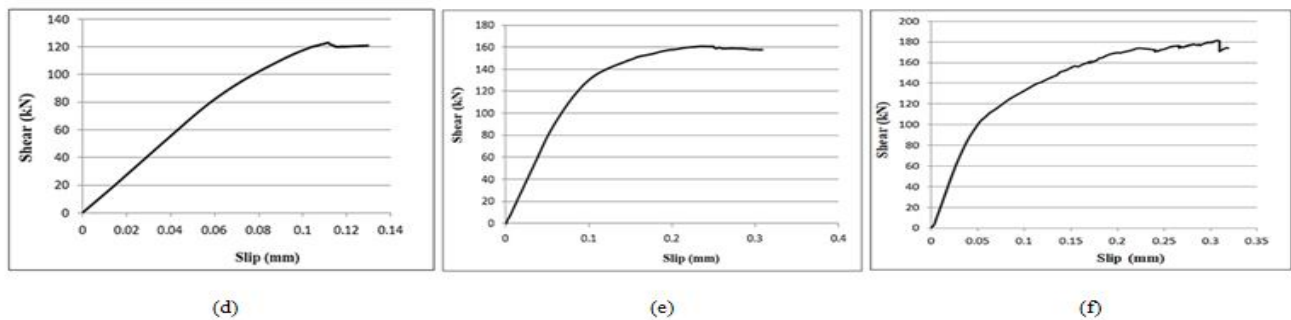

Fig. 8 Shear vs. Slip Graph of (d) Round Key Dry Joint (e) Slot Key Dry Joint (f) Rectangle Key Dry Joint

Table 3. Details of Ultimate Load of Different Types of Dry Joints

SI No.	Joint name	Ultimate load (kN)	Time of loading at ultimate load (s)
1	Bevelled rectangle key dry joint	90	44.636
2	Bevelled square key dry joint	158.13	51.389
3	Bevelled triangle key dry joint	178	52.85
4	Round key dry joint	123	22.49
5	Slot key dry joint	160.8	47.193
6	Rectangle key dry joint	181.36	61.402

The rectangle key dry joint showed excellent performance in the case of ultimate load. This joint achieved higher value 181.36 kN as ultimate load at higher value of slip before failure.

B. Pressure Developed

The pressure developed in contact region of joint at the time of ultimate load is considered for the study. If the contact region of joint is subjected to higher pressure due to loads during the service life of bridge badly affect the key region. It may leads to the shear failure of joints in the early time. The bevelled triangle key dry joint subjected to greater value of pressure. Rectangle key dry joint has lower pressure in the contact region with higher ultimate load. For most of the joints the bottom portion or bottom face of key is subjected to higher pressure except the round key joint. For the round key joint the higher pressure is at a point in top portion of contact region which is slightly higher than the pressure at bottom portion of key.

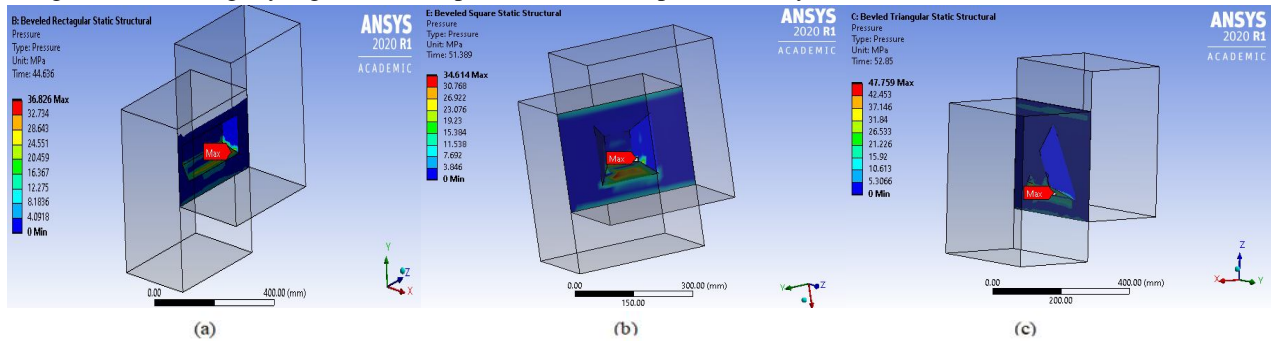

Fig. 9 Pressure in (a) Bevelled Rectangle Key Dry Joint (b) Bevelled Square Key Joint (c) Bevelled Triangle Key Dry Joint

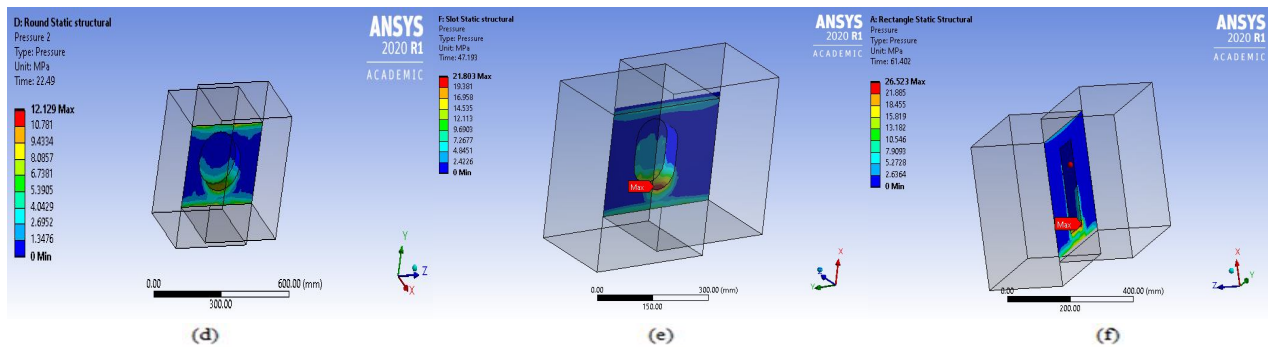

Fig. 10 Pressure in (d) Round Key Dry Joint (e) Slot Key Dry Joint (f) Rectangle Key Dry Joint

Table 4. Details of Pressure Developed at Contact Region in Dry Joints at Ultimate load

SI No.	Joint name	Pressure Max. value (N/mm ²)
1	Bevelled rectangle key dry joint	36.826
2	Bevelled square key dry joint	34.614
3	Bevelled triangle key dry joint	47.759
4	Round key joint	12.129
5	Slot key joint	21.803
6	Rectangle key joint	26.523

C. Total Deformation

The total deformation of key region in contact at the time of ultimate load is considered for the study and not the directional deformation. To get an overview of total deformation of in the key region the figure of total deformation of joint is given in Fig. 11. The vertical loading part of joint subjected to higher total deformation in most of the faces. The rectangle key dry joint attained the maximum value of total deformation 0.297 mm in key region before failure.

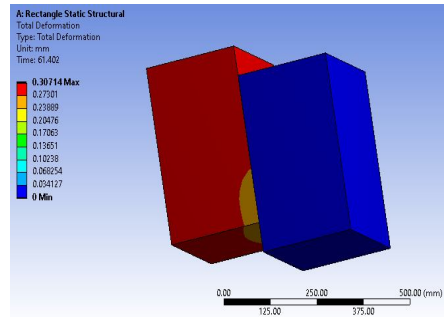

Fig. 11 Typical Total Deformation in Dry Joint

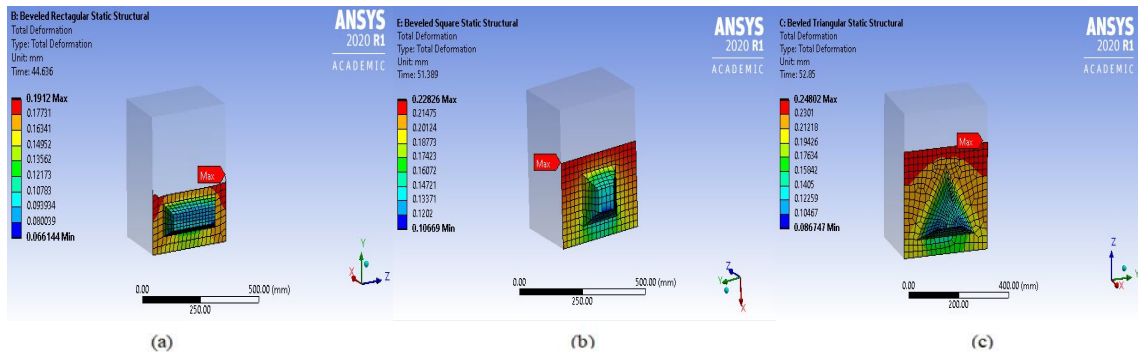

Fig. 12 Total Deformation in keyed region of (a) Bevelled Rectangle Key Dry Joint (b) Bevelled Square Key Dry Joint (c) Bevelled Triangular Key Dry Joint

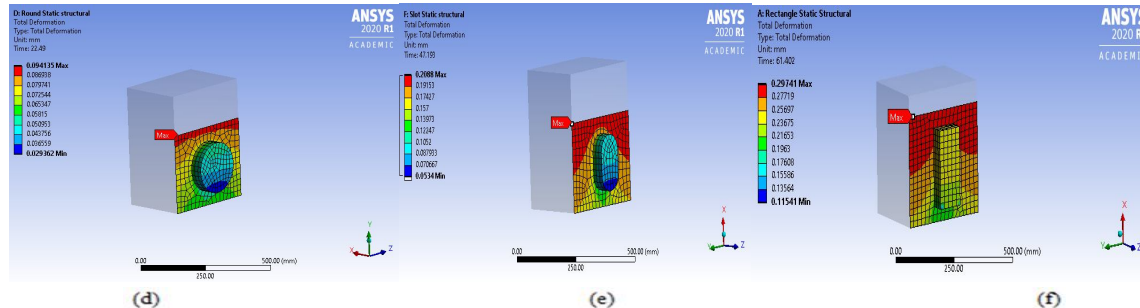

Fig. 13 Total Deformation in keyed region of (d) Round Key Dry Joint (e) Slot Key Dry Joint (f) Rectangle Key Dry Joint

Table 5 Details of Total Deformation in Different Types of Dry Joints at Ultimate load

SI No.	Joint name	Total Deformation	
		Min. value (mm)	Max. value (mm)
1	Bevelled rectangle key dry joint	0.066	0.191
2	Bevelled square key dry joint	0.106	0.228
3	Bevelled triangle key dry joint	0.086	0.248
4	Round key joint	0.029	0.094
5	Slot key joint	0.053	0.208
6	Rectangle key joint	0.115	0.297

IV. CONCLUSIONS

From this study it was found that the shape of shear key affects the behavior of dry joints. All dry joints with new key shape have higher ultimate load than the dry joint with standard key. Rectangle key dry joint performance was excellent in ultimate load, pressure in contact region and total deformation in key region. It attained higher value of ultimate load and total deformation before failure. It subjected to lower pressure in contact region even in the higher ultimate load compared to other dry joints. The all key shapes can be used as a substitute for the present shear key shape to improve the performance of dry joint of PCSBs in ultimate load. Rectangle key shape is the best shear key shape for dry joint in PCSBs to improve the overall performance.

REFERENCES

- [1] Wenqi Hou , Meng Peng , Bo Jin, Yong Tao, Wei Guo and Lingyu Zhou, “Influencing Factors and Shear Capacity Formula of Single-Keyed Dry Joints in Segmental Precast Bridges under Direct Shear Loading”, Applied Sciences, Volume 10, Issue 18, 2020, <https://doi.org/10.3390/app10186304>.
- [2] Sang-Hyo Kim, Jae-Gu Choi, Sejun Park, Hyunmin Lee and Won-Ho Heo, “Development of a Skewed Pipe Shear Connector for Precast Concrete Structures”, Materials (Basel, Switzerland), 10(5), 2017, <https://doi.org/10.3390/ma10050531>.
- [3] Anurak Sangkhon, and Chaisak Pisitpaibool, “Shear Strength Test of Joint with Different Geometric Shapes of Shear Keys between Segments of Precast Segmental Bridge”, International Transaction Journal of Engineering, Management, & Applied Sciences & Technologies, Volume 8, No.1, 2017, ISSN 2228-9860 eISSN 1906-9642, <http://TUENGR.COM/V08/023.pdf>.
- [4] Haibo Jiang, Shaodi Wang, Zhuangcheng Fang, Gongfa Chen and Jiahang Li, “Numerical analysis on the shear behavior of single-keyed dry joints in precast high-strength concrete segmental bridges”, Mathematical Biosciences and Engineering, Volume 16, Issue 4, 3144–3168, 2019.
- [5] Yang, In-Hwan; Kim, Kyung-Cheol and Kim, Young-Joon, “Shear Strength of Dry Joints in Precast Concrete Modules”, Thirteenth East Asia-Pacific Conference on Structural Engineering and Construction (EASEC-13), September 11-13, 2013, Sapporo, Japan. 1-5-3., 1-5-3.
- [6] Benjamin Raison R and Freeda Christy C, “Review on Shear Slip of Shear Keys in Bridges”, International Journal of Scientific & Engineering Research, Volume 7, Issue 4, 2016, ISSN 2229-5518.
- [7] Heru Purnomo, Muhammad Jaufar Al Fatih, Sekar Mentari and Gambiro Soeprapto, “Numerical Modelling, Simulation and Experimentation of Steel Shear Keys Dry Joints”, International Journal of Mechanical Engineering and Robotics Research, Vol. 9, No. 4, 2020.
- [8] N. Krishna Raju, *Prestressed Concrete*, Edition 4, Tata McGraw-Hill, New Delhi, 2006.
- [9] Indian Standard IS 1343: 2012 “Prestressed concrete - Code of Practice (Second Revision)”, BIS 2012, November 2012 Bureau of Indian Standards Manak Bhavan, 9 Bahadur Shah Zafar Marg, New Delhi 110002.
- [10] <https://www.youtube.com/watch?v=h2BApwflt3E>
- [11] <https://www.nbmcw.com/tech-articles/precast-construction/40467-precast-concrete-construction-technologies-for-metro-projects-in-india.html>



10.22214/IJRASET



45.98



IMPACT FACTOR:
7.129



IMPACT FACTOR:
7.429



INTERNATIONAL JOURNAL FOR RESEARCH

IN APPLIED SCIENCE & ENGINEERING TECHNOLOGY

Call : 08813907089  (24*7 Support on Whatsapp)