



IJRASET

International Journal For Research in
Applied Science and Engineering Technology



INTERNATIONAL JOURNAL FOR RESEARCH

IN APPLIED SCIENCE & ENGINEERING TECHNOLOGY

Volume: 9 Issue: IV Month of publication: April 2021

DOI: <https://doi.org/10.22214/ijraset.2021.33736>

www.ijraset.com

Call:  08813907089

E-mail ID: ijraset@gmail.com

Design and Fabrication Mini CNC Milling Machine

Prof. Ravi Bisane¹, Mr. Vivek Potreddiwar², Mr. Vrushabh Palandurkar³, Mr. Vikrant Kakade⁴, Mr. Raj Bansod⁵, Mr. Vijay Shastrakar⁶

^{1, 2, 3, 4, 5, 6} Govindrao Wanjari College of Engineering and Technology Nagpur, Mechanical Engineering Department

Abstract: This paper reports the design and fabrication of small-scale CNC milling machine which is capable of 3-axis simultaneous interpolated operation. The idea behind this work is to design low cost and easy portable machine which is achieved by incorporating the features of a standard PC interface with ATMEGA 328 micro controller based CNC system in an Arduino. The system also features an offline G-Code parser and then interpreted on the micro-controller from a USB. The main objective of this work is the development of a model of CNC machine on educational purposes. The design CNC machine with workspace of 150mm ×150mm using a precision stepper motors that combined with lead screws in moving the axis smoothly on linear bearings that increases a more precisely results obtain.

I. INTRODUCTION

One of the fastest growing industries in the modern era is the semiconductor industry. With this the use of electronic product i.e. PCB is increasing day by day. Due to the high cost of commercial and often imported PCB prototyping equipment, there is a severe lack of practical hands-on PCB design teaching and learning in the world. This situation can be remedied with the microcontroller and microcomputers which are having affordability and versatility, commercial off-the-shelf components like actuators, sensors as well as free, open source software, which can be integrated for the design of low-cost PCB prototyping machines for electronic industries.

People use cheap methods like chemical etching which is most famous in small scale industries to design PCB circuits, but these methods lack sufficient consistency for surface mount devices (SMDs) and the drilling of holes is very tedious as it has to be done manually. Further, the environmental and health hazards risk is high in these processes. Development of safe and high-resolution milling and drilling of PCBs is enabled using routing which overcomes many difficulties involved in the traditional methods

II. METHODOLOGY

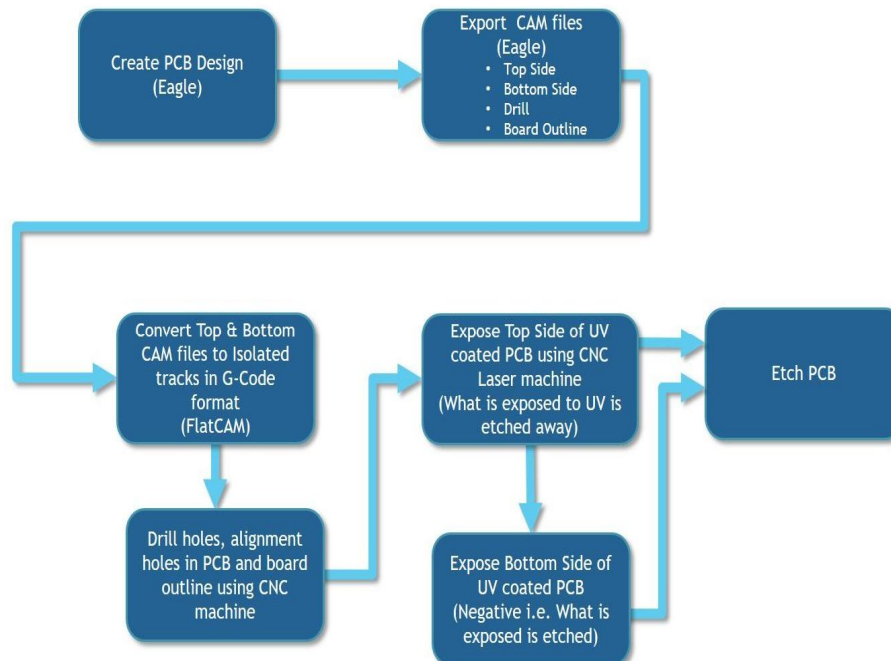

A. Planning and Process

Laser Engraver development cycle include three major phases. Very first stage is mechanical design using Solid works. 3Modelling of each part has been done which include X, Y & Z-axis and final assembly will be done in Solid works software and converting into 2D and BOM generation. After this we are going for the manufacturing of the different parts using 3D printing.

Second phase includes understanding the working area of the Laser engraver machine and Kinematics of the Cartesian coordinate systems is analyzed. In this phase, we are also going for type of microcontroller is used and different electronic components & their interface with Microcontroller and programming. We are going do the wiring of all electronic components has been done.

Third and final phase is understanding G-codes and M-codes & Interfacing software to do the Job by using G-Codes and M codes.

B. Experimental set-up or Model Design Description

The heart of this system is Arduino UNO which controls all the operations. For precise motion control of the 3-axis the stepper motor is employed which is known for its precise movement with each input pulse. However, the input signals to the stepper motor are produced by the microcontroller.

Arduino Uno). The spindle motor 775 is mounted on gantry and it is powered by SMPS which varies its RPM according to operating voltage. Stepper motor driver is used as an interfacing component between the microcontroller and stepper motor which is powered by separate power

1) *Software System:* For the designing of the pcb we are using eagle layout editor. this software provides platform for designing considering various aspects like thickness, type of material, and workspace. ink space/ universal g-code sender is used to convert the design into g-codes. arduino use these g- codes to provide actuating signals to the stepper motor and hence the milling is done.

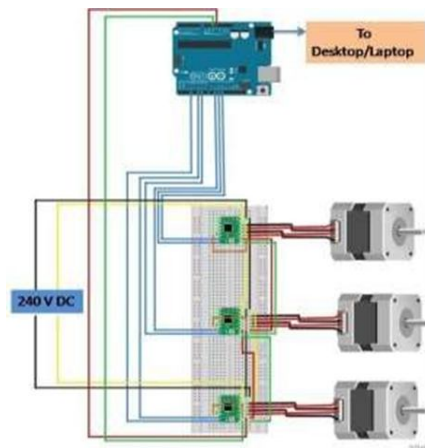

2) *Protection System:* This system is designed by using IR sensor and is the most prominent feature of our paper. IR sensor is device which consist of transmitter and receiver which is used to detect the presence of any object within its vicinity.

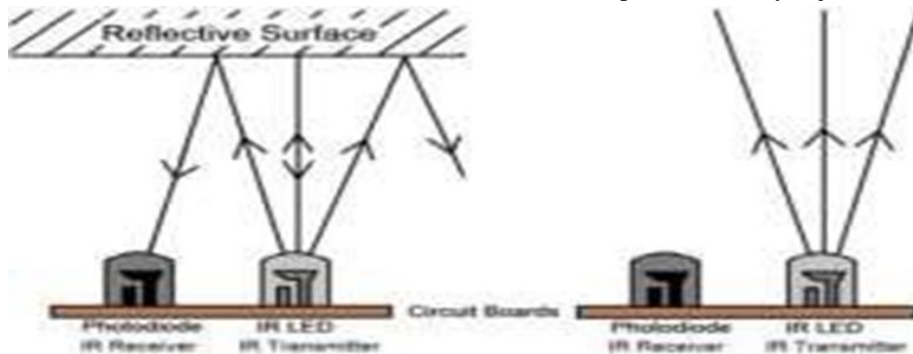

During the engraving operation of the spindle motor if the IR sensor senses any external obstruction within the working premises of the machine it will pass these signals to the microcontroller which will result in turning on of buzzer and will lead to the termination of engraving operation. By implementing this protection method, we can eliminate the future accidents and human injuries which makes the machine safer for unskilled and beginner.

III.COMPONENTS

A. List of Mechanical Components

Sr. No	Components	Specifications
1)	Aluminum Extrusion	2020
2)	Steel Shaft	8 mm
3)	Ball Bearing	LM8UU
4)	Linear Bearing Slide Unit	SC8UU
5)	Shaft Coupler	Flexible Type
6)	Collet	0.5-3 mm
7)	Threaded Rod	8 mm
8)	Lead Screw	Pitch -2 mm
9)	Auxiliaries	

B. List of Electrical Components

Sr.No.	Components	Specifications	Quantity
1.	Stepper Motor Nema 17	4 kg-cm, 1.8 degree	2
2.	Stepper motor Nema 17	5.5 kg-cm, 1.8 degree	1
3.	Spindle Motor 775	12000 RPM, 12V,1.2A,79 N-cm	1
4.	Arduino UNO	ATmega328P	1
5.	Stepper Motor Driver	A4988	3
6.	Power Supply	12-24V	1

IV.RESULT & CONCLUSIONS

A cost-efficient PCB milling machine is designed and developed by optimizing the cost for milling of PCB with surface mount technology. The machine is fabricated with inexpensive and commercial open source software and hardware components and can be adapted and advanced for future requirement. We can add the advance features like soldering tools, human safety, fully automated PCB machine with pick and place assembly, feedback, IoT, etc. We can also make changes in stepper motors according to requirement. We can also change the processor in order to add more features to machine.

ACKNOWLEDGMENT
The heading of the Acknowledgment section and the References section must not be numbered.

Causal Productions wishes to acknowledge Michael Shell and other contributors for developing and maintaining the IEEE LaTeX style files which have been used in the preparation of this template. To see the list of contributors, please refer to the top of file IEEETran.cls in the IEEE LaTeX distribution.

V. FUTURE SCOPE

This project primarily aims at making the process of PCB fabrication a more easier and accurate process. We also aim to incorporate the performance and efficiency of an industrial milling machine into a compact, cost efficient version. The machine was constructed with parts designed using Solid Works to further emphasize the latter statement.

A CNC shield is mounted on the Arduino Uno for improving the features and power capacity. Sliders are installed on the axes for the ease of movement. The UGS software when provided with proper G-code ensures the proper movement of the stepper motors. Limit switches ensures that the robot works within the workspace. Various designs were given as input, and the time for completing the task were recorded as a sum of engraving and drilling time.



REFERENCES

- [1] Leone, "wood engraving by Q-switched diodepumped frequency-doubled Nd: YAG green laser" *Optics and lasers in engineering* 47(2009) 161-168.
- [2] Yusri Yusof, " New Interpretation Module for Open Architecture Control based CNC Systems " 12th global conference on sustainable manufacturing, *Procedia CIRP* 26 (2015) 729-734."
- [3] Georgi M. Martinova, Aleksandra I. Obuhova, Lilija I. Martinovaa, Anton S. Grigorieva. "An approach to building specialized CNC system for non-traditional processes". *Procedia CIRP* 14 (2014) 511-516.
- [4] Yu D, Hu Y, Xu XW, Huang Y, Du S. "An open CNC system based on component technology". *IEEE Trans Autom Sci Eng* 2009;6.
- [5] Correa J, Toombs N, Ferreria PM. "Implementation of an openarchitecture control for CNC system based on open-source electronics". *Proceedings of the ASME 2016 IMECE* 2016.



10.22214/IJRASET



45.98



IMPACT FACTOR:
7.129



IMPACT FACTOR:
7.429



INTERNATIONAL JOURNAL FOR RESEARCH

IN APPLIED SCIENCE & ENGINEERING TECHNOLOGY

Call : 08813907089  (24*7 Support on Whatsapp)