



IJRASET

International Journal For Research in
Applied Science and Engineering Technology



INTERNATIONAL JOURNAL FOR RESEARCH

IN APPLIED SCIENCE & ENGINEERING TECHNOLOGY

Volume: 9 Issue: V Month of publication: May 2021

DOI: <https://doi.org/10.22214/ijraset.2021.34152>

www.ijraset.com

Call:  08813907089

E-mail ID: ijraset@gmail.com

Comparative Analysis of Underground Water Tank

Mr. Sanket Bayaskar¹, Dr. Swati Ambadkar²

¹P.G. Student, ²Assistant Professor, Department of Civil Engineering, G. H. Rasoni University, Amravati, Maharashtra, India

Abstract: The water tank is a container for storing water. The need for a water tank is as old civilization, to provide storage of water for use in many applications, drinking water, irrigation agricultural, fire suppression, agricultural farming, chemical manufacturing as well as many other uses. An Underground water storage tanks (or sub-surface tanks) are used for underground storage of potable drinking water, wastewater & rainwater collection. And it is a water storage structure constructed below the ground. The maximum horizontal displacement (X-direction) is found for the model-4 and the value obtained is 5.373 mm while the minimum displacement is observed to be in the model-8 having the value of 0.066 mm. The maximum vertical displacement is found to be in the model-10 and the observed value is 63.439 mm as compared to the other models.

Keywords: Design, analysis, STAAD Pro software, criteria and damage

I. INTRODUCTION

India has In recent years, there has been much emphasis on water supply projects all over the world, which are very essential for the social and industrial development of the country. Water tanks can be of different capacity depending upon the requirement of consumption. Based on the location the water tanks are classified into three ways:

- A. Underground water tanks
- B. Tank resting on grounds
- C. Elevated or overhead water tanks.

II. REVIEW OF LITERATURE

Addala, Ayodeji, A.S., et al [1] studied design recommendation for storage tanks and their supports With emphasis on seismic design However, It is envisaged by publishing the English version of “Design Recommendation for Storage Tanks and Their Supports” that the above unique design recommendation will be promoted to the overseas countries who are concerned on the design of storage tanks and the activities of the Architectural Institute of Japan will be introduced them too.

Bajic, S.J., et al [2] studied that it is addressed how this recommendation is in an advanced standard in terms of the theory of the restoring force characteristics of the structure considering the Elephant Foot Bulge (EFB), the effect of the uplifting tank and the plastic deformation of the bottom plate at the shell-to-bottom juncture in the event of earthquake.

Harsha, K., et al [4] studied that the seismic design calculations for other types of storage tanks have been similarly reviewed and amended to take into account data obtained from recent experience and experiments. Design recommendation for sloshing phenomena in tanks has been added in this publication.

III. MODELING

The modeling is carried out in the STAAD software, mentioned as follows.

- 1) Model-I: Rectangular water tank (6m X 10m)-0.23m thickness
- 2) Model-II: Rectangular water tank (6m X 10m) – 0.3m thickness
- 3) Model-III: Rectangular water tank (6m X 10m) – 0.5m thickness
- 4) Model-IV: Rectangular water tank (7m X 11m) – 0.23m thickness
- 5) Model-V: Rectangular water tank (7m X 11m) – 0.3m thickness

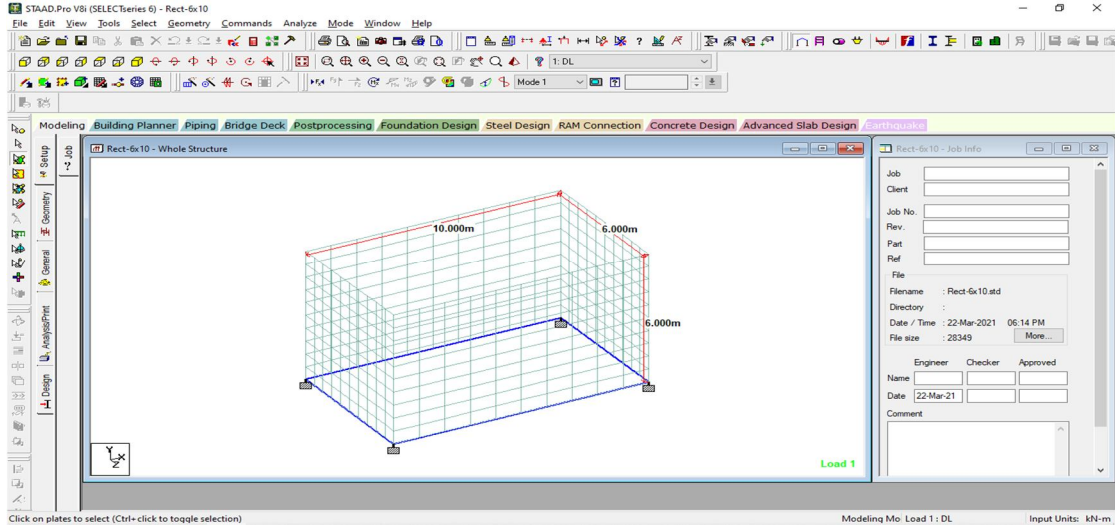

Fig. No.1: Dimensions of Model-I

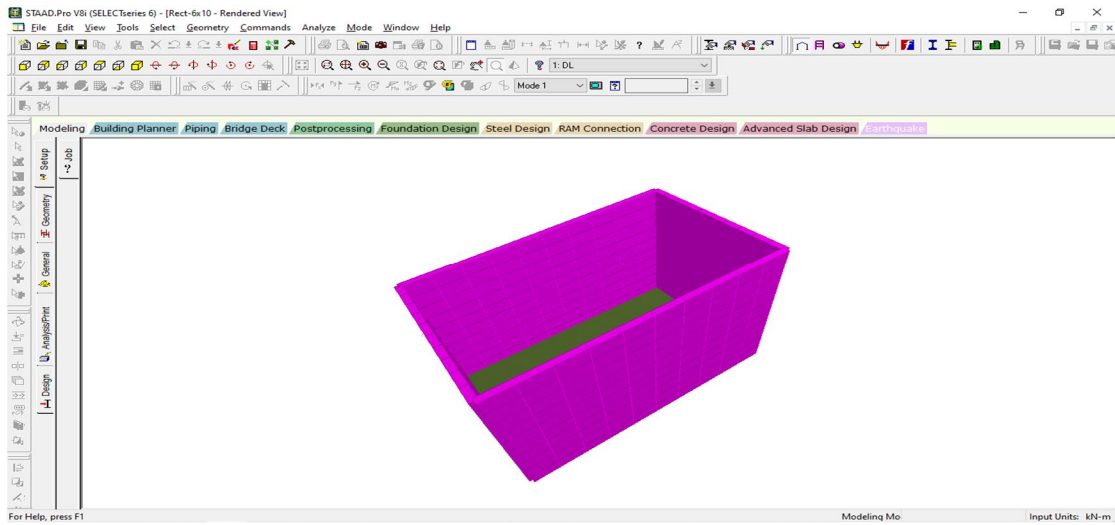

Fig. No.2: 3D of Model-I

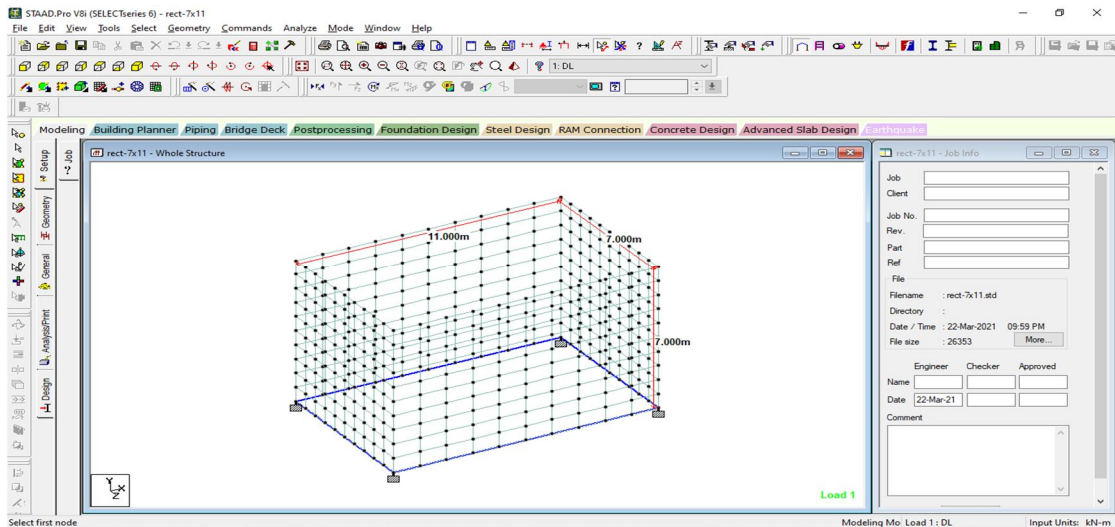

Fig. No.3: Dimensions of Model-IV

IV. RESULTS

The analysis is carried out in STAAD software and the results in terms of shear force, bending moment and other parameter is obtained as follows.

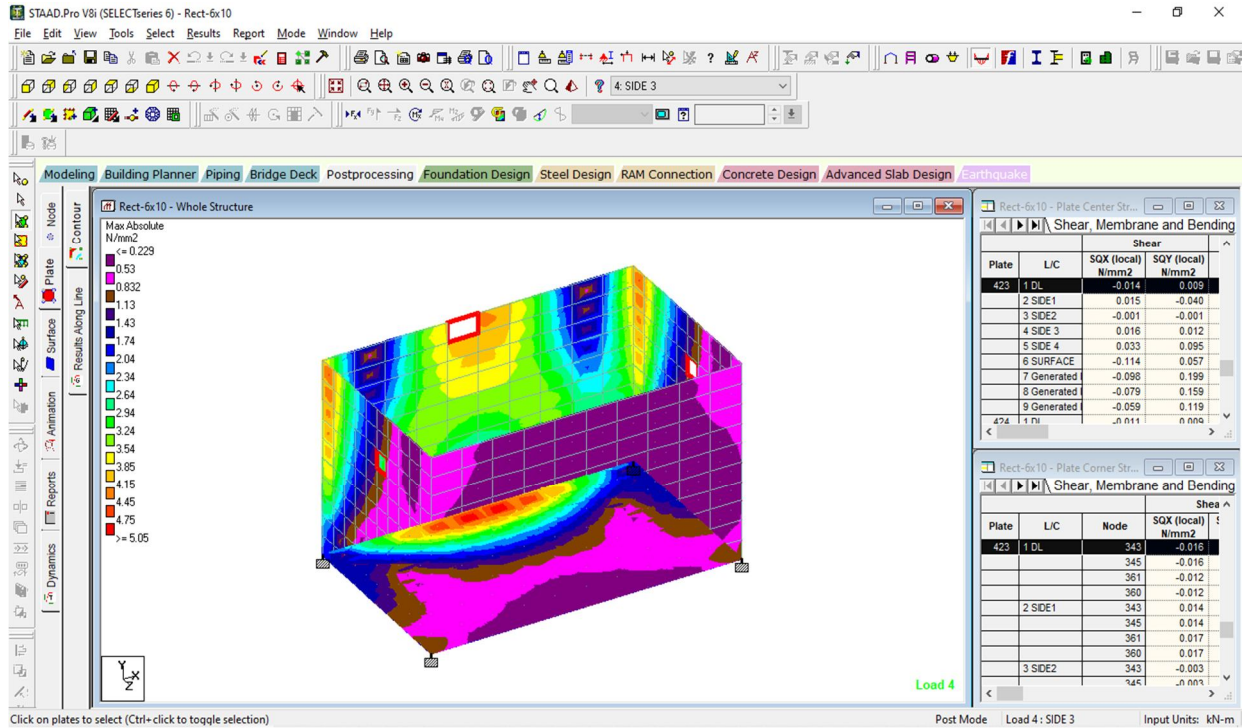

Fig. No.4: Maximum absolute stress for model-I

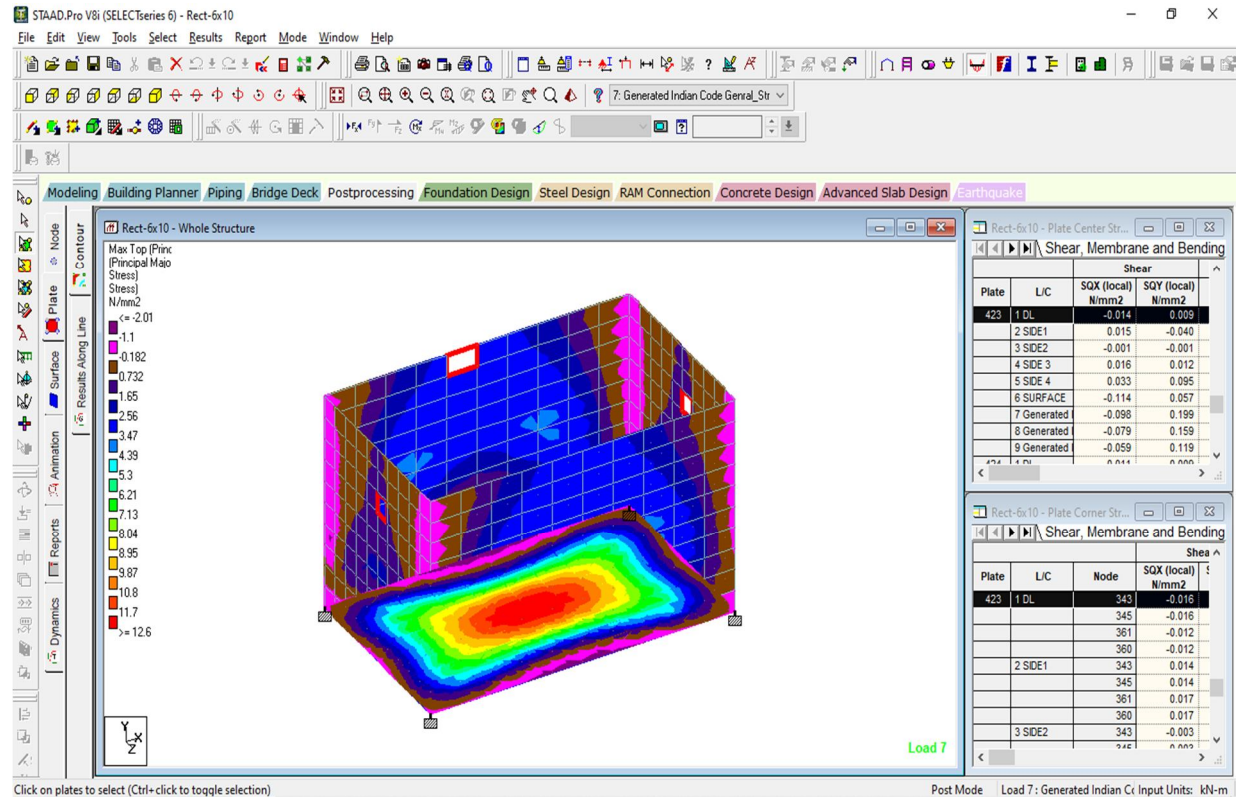

Fig. No.5: Maximum top Principal stress of model-I

Table No.1: Displacement of model-II

	Node	Horizontal X mm	Vertical Y mm	Horizontal Z mm	Resultant mm
Max X	176	1.472	-0.009	0	1.472
Min X	297	-1.472	-0.009	0	1.472
Max Y	11	0.007	0.035	0.128	0.133
Min Y	121	0	-0.702	-0.075	0.706
Max Z	436	0	-0.04	7.364	7.364
Min Z	18	0	-0.04	-7.364	7.364
Max rX	121	0	-0.3	-0.013	0.3
Min rX	350	0	-0.3	0.013	0.3
Max rY	12	0.002	-0.036	-3.922	3.922
Min rY	433	0.002	-0.036	3.922	3.922
Max rZ	171	0.078	-0.463	0	0.469
Min rZ	242	-0.078	-0.463	0	0.469
Max Rst	18	0	-0.04	-7.364	7.364

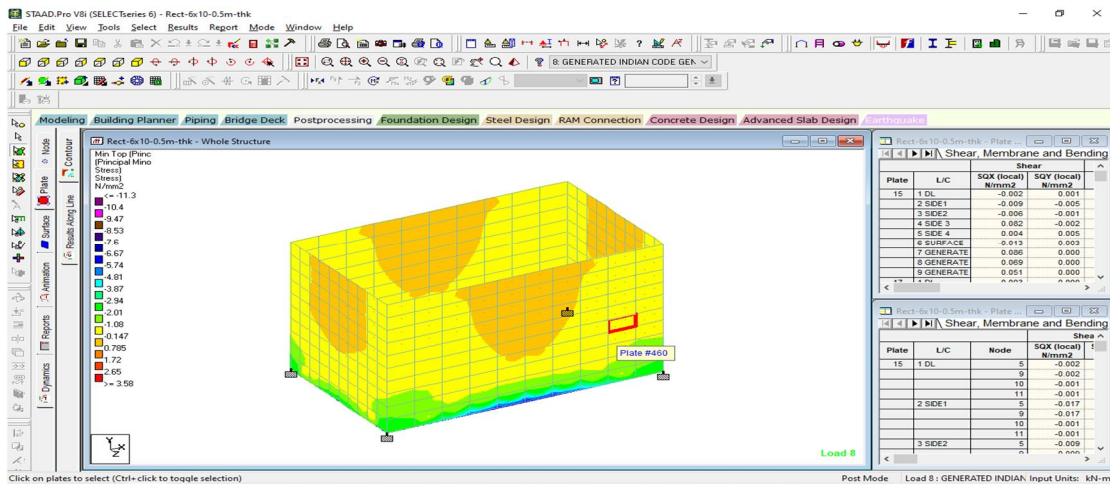

Fig. No.6: Top Principal stresses on model-III

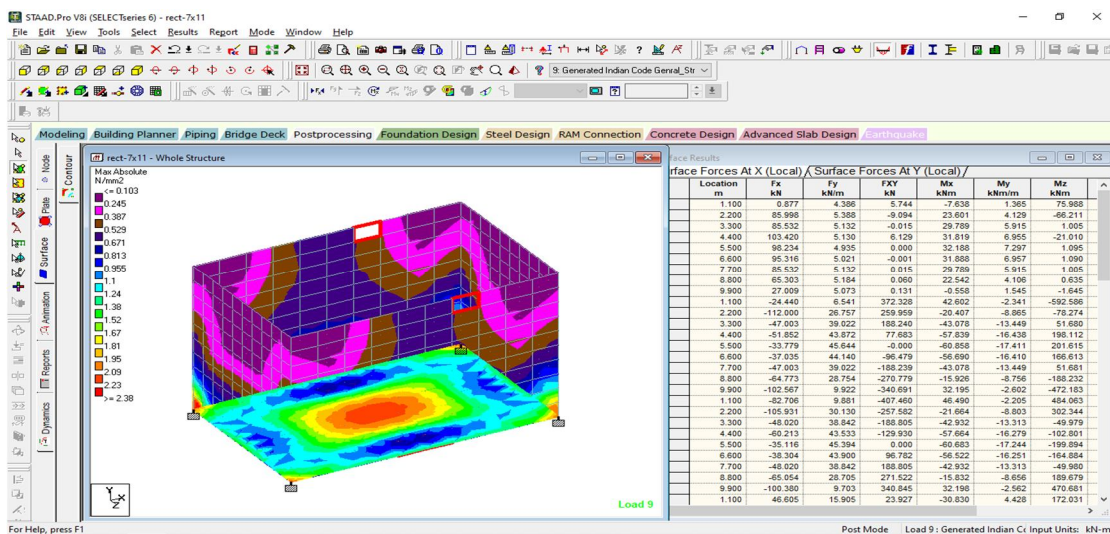

Fig. No.7: Maximum absolute stress on the model-IV

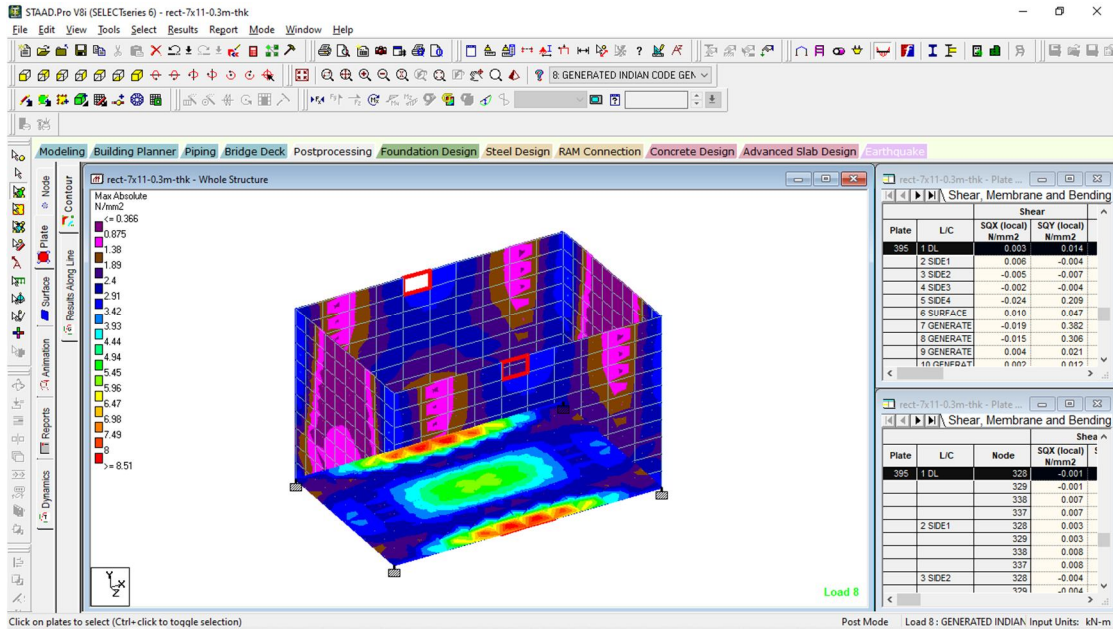

Fig. No.8: Maximum absolute stresses on model-V

V. CONCLUSION

The conclusions from the above study are as follows:

- A. The maximum horizontal displacement (X-direction) is found for the model-4 and the value obtained is 5.373 mm while the minimum displacement is observed to be in the model-8 having the value of 0.066 mm.
- B. The maximum vertical displacement is found to be in the model-4 and the observed value is 63.439 mm as compared to the other models.
- C. The maximum horizontal reaction (Fx-kN) is observed to be in the model-4 and the value obtained is 640.936 kN while the minimum reaction is in the model-8 and the obtained value is 57.05 kN.
- D. The maximum horizontal reaction (Fz-kN) is observed to be in the model-3 and the value obtained is 426.932 kN while the minimum reaction is in the model-8 and the obtained value is 56.7 kN.

REFERENCES

- [1] Addala, Ayodeji, A.S., Abubakar, S. and Samuel, E., 2017. Physicochemical Analysis of Underground Water in Zaria Metropolis, Kaduna State, Nigeria. American Journal of Chemical Engineering, 5(6), pp.158-162.
- [2] Bajic, S.J., Luo, S., Jones, R.W. and McClelland, J.F., 1995. Analysis of underground storage tank waste simulants by fourier transform infrared photoacoustic spectroscopy. Applied spectroscopy, 49(7), pp.1000-1005.
- [3] Banjac, M., 2015. Achieving sustainable work of the heat pump with the support of an underground water tank and solar collectors. Energy and Buildings, 98, pp.19-26.
- [4] Harsha, K., Reddy, K.K.K. and Kala, K.S., 2015. Seismic Analysis and Design of INTZE Type Water Tank. International Journal of Science Technology and Engineering, ISSN.
- [5] Imanishi, Y., Kokubo, K. and Tatehata, H., 2006. Effect of underground water on gravity observation at Matsushiro, Japan. Journal of Geodynamics, 41(1-3), pp.221-226.
- [6] Nimade, A., Soni, N., Varma, G., Joshi, V. and Chaurasia, S., 2018. Parametric Study of Underground Water Tank using FEM. International Journal of Science Technology & Engineering, 4(9), pp.94-98.
- [7] Sani, J.E., Nwadiogbu, C.P. and Yisa, G.L., 2014. Reliability Analysis of an Underground Reinforced Concrete Rectangular Water Tank. Journal of Mechanical and Civil Engineering, 11(1), pp.58-68.
- [8] Shakib, H. and Omidinasab, F., 2011. Effect of earthquake characteristics on seismic performance of RC elevated water tanks considering fluid level within the vessels. Arabian Journal for Science and Engineering, 36(2), pp.227-243.
- [9] Shi, H. and Liu, B., 2010. Design and seepage discharge analysis of artificial water curtains for water sealed underground petroleum storage caverns in rock. Chinese Journal of Geotechnical Engineering, 32(1), pp.130-137.
- [10] Soroushnia, S., Tafreshi, S.T., Omidinasab, F., Beheshtian, N. and Soroushnia, S., 2011. Seismic performance of RC elevated water tanks with frame staging and exhibition damage pattern. Procedia engineering, 14, pp.3076-3087.



10.22214/IJRASET



45.98



IMPACT FACTOR:
7.129



IMPACT FACTOR:
7.429



INTERNATIONAL JOURNAL FOR RESEARCH

IN APPLIED SCIENCE & ENGINEERING TECHNOLOGY

Call : 08813907089  (24*7 Support on Whatsapp)