



# IJRASET

International Journal For Research in  
Applied Science and Engineering Technology



---

# INTERNATIONAL JOURNAL FOR RESEARCH

IN APPLIED SCIENCE & ENGINEERING TECHNOLOGY

---

**Volume: 9      Issue: V      Month of publication: May 2021**

**DOI: <https://doi.org/10.22214/ijraset.2021.34159>**

**[www.ijraset.com](http://www.ijraset.com)**

**Call:  08813907089**

**E-mail ID: [ijraset@gmail.com](mailto:ijraset@gmail.com)**

# Microcontroller based Heart Rate Monitor

Shripad Desai<sup>1</sup>, Devender Kumar J Pal<sup>2</sup>

<sup>1</sup>Assistant Professor, <sup>2</sup>Student, Department of Electrical Engineering, Bharti Vidyapeeth Deemed (to be) University College of Engineering, Pune

**Abstract:** With technological progress, things are becoming more and more easier and simpler for us. This unit explores the fundamental meanings of The project had to be better understood and further established by the as part of this initiative, technical requirements to be applied.

## I. INTRODUCTION

A basic heart rate sensor using the 8051 microcontroller is explored in this paper. The microcontroller used here is the AT89S52. Using the IR reflection process, the system detects the heart rhythm from the fingertip and reveals it in beats per minute on a three-digit seven-segment monitor. The circuit has a 4-beat per minute precision and is very easy to use.

The sensor shines through the ear with a light lobe (a small, very bright LED) and tests the light sent to the Light-Based Resistor. Inside the circuit, the augmented signal is reversed and filtered. To measure the heart rhythm on the basis of blood supply to the tip of the finger. The technique used here for sensing heart rate is called Photoplethysmography in medical terms.

## II. PHOTOPLETHYSMOGRAPHY

The method of optically measuring the volumetric calculation of an organ is Photoplethysmography. Few typical applications of Photoplethysmography are pulse oximetry, cardiovascular monitoring, respiration detection, heart rate monitoring, etc. Let us take a look at the implementation of Photoplethysmography from the finger tip of heart rate control. The volume of blood inside the fingertip increases when the heart expands (diastole). The amount of blood inside the fingertip decreases when the heart contracts. The resulting blood volume pulsing inside the fingertip is directly proportional to the heart rate, and if you can count the number of pulses in a minute, that's the heart rate in beats per minute (bpm). An IR transmitter/receiver pair is put in close contact with the fingertip for this. When the heart is beating under the sensor, the volume of blood cells rises and this reflects more IR waves to the sensor and decreases the intensity of the reflected beam when there is no beat. The pulsating reflection is converted by the sensor to an appropriate current or voltage pulse. Appropriate electronic circuits process the sensor output to obtain a visible indication (digital display or graph).

## III. WORKING OF HEART RATE SENSOR

A light detector and a bright red LED are composed of the heartbeat sensor circuit diagram. The LED must have a super-bright intensity when full light passes and expands if the detector senses a finger put on the LED.

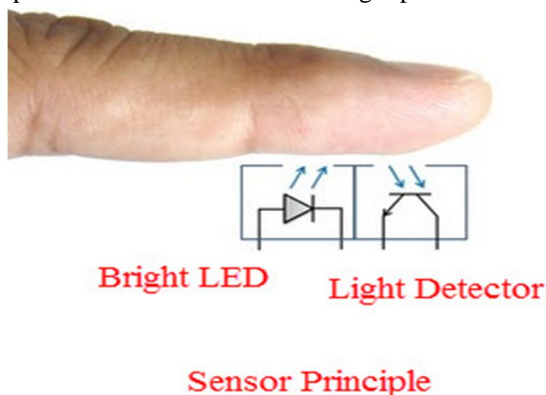

Fig 1: - Heart Rate Sensor Principle

Now as blood is pumped by the heart into the blood vessels, the finger becomes somewhat opaquer as a result, less light enters the detector from the LED. The detector signal becomes different with every heart pulse produced. The varying signal from the detector is transformed into an electrical pulse. This electrical signal is amplified and activated by an amplifier that generates a +5V logic level signal output. A LED monitor that blinks on each heartbeat rate often directs the output signal.

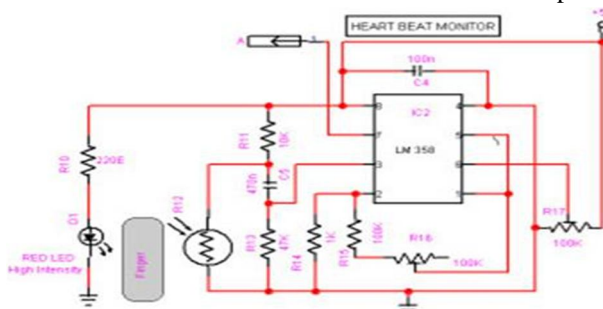

Fig 2: - Heart Rate Sensor Circuit Diagram

#### IV. CONTROL UNIT (8051 MICROCONTROLLER)

Atmel's Microcontroller AT89S52. The specified catch Plays the pins and fundamental microcontroller specifications, Allow versatility with it. The controllers through overview is given as follow:

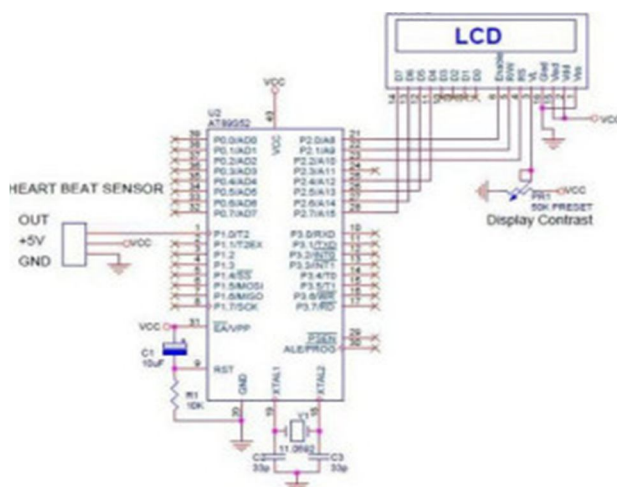

Fig 3: - Control Unit Diagram

The AT89S52 is an Intel core ATMEL controller with MCS-51. As given above, it has the same pin configuration. The AT89S52 is a high-performance low-power, 8-bit CMOS Microcomputer with Downloadable Flash 8K bytes Just read memory and 2K bytes of memory are programmable and erasable. From EEPROM. The system is manufactured using the elevated Atmel Non-volatile memory technology with density which is consistent with set and pin out the industry standard 80C51 guidelines.

The on-chip Downloadable Flash enables in-system reprogramming of the program memory with an SPI serial interface or a traditional non-volatile memory programmer. The Atmel AT89S52 is a powerful microcomputer that offers a highly scalable and cost-effective solution for many embedded control applications by integrating a compact 8-bit CPU with downloadable Flash on a monolithic chip. The AT89S52 offers the following basic features: Downloadable Flash 8K bytes, EEPROM 2K bytes, RAM 256 bytes, 32 I/O blocks, programmable watchdog timer, two Data Pointers, three 16-bit timer/counters, a six-vector timer, two-level interrupt, a full duplex serial port, on-chip oscillator, and clock circuitry. Furthermore, the AT89S52 is designed for service down to zero frequency with static logic and supports two selectable power saving modes for software. The idle mode prevents the CPU while enabling the continued running of the RAM, timer/counters, serial port, and system interrupt. The Power Down Mode preserves the RAM content, but freezes the oscillator before the next interrupt or hardware reset, removing all other chip functions. You will alter the Downloadable Flash one byte at a time and it is accessible via the serial interface of the SPI. Active Keeping RESET pushes the SPI bus into a serial programming interface and until Lock Bit 2 has been enabled, enables the program memory to be written to or read from.



#### A. Feature

Compatible with MCS-51™ Products 8K bytes of In-System Reprogrammable Downloadable Flash Memory SPI Serial Interface for Program Downloading Endurance: 1,000 Write/Erase Cycles 4.0V to 5.5V Operating Range Fully Static Operation: 0 Hz to 33 MHz 256 x 8-bit Internal RAM 32 Programmable I/O Lines Three 16-bit Timer/Counters Eight Interrupt Sources Full Duplex UART Serial Channel Low Power Idle and Power Down Modes Interrupt Recovery from Power Down Mode

#### B. Advantage

Less power consumption

Low cost

Less space required

High speed

#### C. Pin Understanding

- 1) **VCC:** Stress of supply. **GND:** Ground., **Port 0:** Port 0 is a bidirectional I/O port for an 8-bit free drain. Every pin is able to sink eight TTL inputs as an output port. The pins can be used as high impedance inputs while 1s are written to Port 0 pins. Port 0 can also be programmed to be the low-order address/data bus multiplexed during external application and data memory entry. In the mode here.
- 2) **Port 1:** Port 1 is an 8-bit bidirectional I/O port with internal pull-ups. The Port 1 output buffers can sink/source four TTL inputs. When 1s are written to Port 1 pins, they are pulled high by the internal pull-ups and can be used as inputs. As inputs, Port 1 pins that are externally being pulled low will source current (IIL) because of the internal pull-ups.
- 3) **Port 2:** Port 2 is an 8-bit bidirectional I/O port with internal pull-ups. The Port 2 output buffers can sink/source four TTL inputs. When 1s are written to Port 2 pins, they are pulled high by the internal pull-ups and can be used as inputs. As inputs, Port 2 pins that are externally being pulled low will source current (IIL) because of the internal pull-ups. Port 2 emits the high-order address byte during fetches from external program memory and during accesses to external data memory that uses 16-bit addresses (MOVX @ DPTR). In this application, Port 2 uses strong internal pull-ups when emitting 1s. During accesses to external data memory that uses 8-bit addresses (MOVX @ RI), Port 2 emits the contents of the P2 Special Function Register. Port 2 also receives the high order address bits and some control signals during Flash programming and verification.
- 4) **Port 3:** Port 3 is an 8-bit bidirectional I/O port with internal pull-ups. The Port 3 output buffers can sink/source four TTL inputs. When 1s are written to Port 3 pins, they are pulled high by the internal pull-ups and can be used as inputs. As inputs, Port 3 pins that are externally being pulled low will source current (IIL) because of the pull-ups.
- 5) **RST:** Reset input. A high on this pin for two machine cycles while the oscillator is running resets the device. This pin drives high for 98 oscillator periods after the Watchdog times out. The DISRTO bit in SFR AUXR (address 8EH) can be used to disable this feature. In the default state of bit DISRTO, the RESET HIGH out feature is enabled.
- 6) **ALE/PROG:** Address Latch Enable (ALE) is an output pulse for latching the low byte of the address during accesses to external memory. This pin is also the program pulse input (PROG) during Flash programming. In normal operation, ALE is emitted at a constant rate of 1/6 the oscillator frequency and may be used for external timing or clocking purposes. Note, however, that one ALE pulse is skipped during each access to external data memory.
- 7) **PSEN:** Program Store Enable (PSEN) is the read strobe to external program memory. When the AT89S52 is executing code from external program memory, PSEN is activated twice each machine cycle, except that two PSEN activations are skipped during each access to external data memory.
- 8) **EA/VPP:** External Access Enable. EA must be strapped to GND in order to enable the device to fetch code from external program memory locations starting at 0000H up to FFFFH. Note, however, that if lock bit 1 is programmed, EA will be internally latched on reset. EA should be strapped to VCC for internal program executions. This pin also receives the 12-volt programming enable voltage (VPP) during Flash programming.
- 9) **XTAL1 and XTAL2:** X2 and X1 pins are input output pins for the oscillator. These pins are used to connect an internal oscillator to the microcontroller.

### V. WORKING OF CIRCUIT

In this system, a crystal oscillator circuit is connected between the pins 18 and 19 of the AT89S52 microcontroller used for operating the instructions sets at a various clock frequency range. A machine cycle is used to measure the minimum time for executing the single instruction set.

With the assistance of a capacitor and a resistor, the reset circuit is attached to pin 9 of the AT89S52 microcontroller. The other end of the resistor is attached to the ground (20pin) and the other end of the capacitor is connected to the (EA/Vpp) 31 pin. In such a way that they perform a reset mode of operation manually, the resistor and capacitor are connected. If the switch is locked, then the high reset pin is set. The heartbeat sensor attached to the microcontroller's port1.0 pin is used to track heart pulses, and these pulse signals are sent to the microcontroller using the Keil software and compared to the programmed data stored in the microcontroller. The counter in the microcontroller counts these pulses for a given amount of time while the input's heart rate pulses are received. The LCD displays are attached to the AT89S52 microcontroller's 2 pin port. The time period of the pulse of one heartbeat will be one second, and we will have the appropriate result as 60 by dividing 60,000 by 1000, which will then be reflected on the LCD.

## VI. COMPONENTS USED

- 1) *AT89S52 Microcontroller*: The device used in this project is 'AT89S52', which is a typical 8051 microcontroller produced by Atmel Corporation. This Microcontroller is the most important fragment of this project as it controls all the operations of the circuit such as reading heartbeat rate pulses data from the heartbeat sensor.
- 2) *Power Supply*: A step-down transformer, a bridge rectifier, a capacitor, and a voltage regulator make up this power supply block. The single-phase Active Current power supply from the mains is limited to a lower voltage range, which is rectified by a bridge rectifier to Direct Current again. This rectified direct current is filtered and regulated with a capacitor and voltage
- 3) *LCD*: The majority of projects use LCD displays to display data such as pulse rate, body temperature, etc. In programs, such as seven-segment displays and LED displays, separate displays are used. The choice of display depends on the following criteria being considered: display cost, power usage, and ambient lighting conditions.
- 4) *Resistors*: As the ratio of the voltage applied across its terminals and the current flowing through it, resistance is well defined. The performance of the resistor relies on a set voltage that regulates the current that passes through it. In an electronic circuit, the resistor is a passive component used to control the current.
- 5) *Capacitors*: A capacitor's key function is to store charges. The capacitance value product and the voltage applied across a condenser are equal to the charge contained in the condenser.
- 6) *Crystal Oscillator*: A Crystal oscillator circuit is a type of electronic circuit that makes use of a vibrating circuit's mechanical resonance used by varying the frequency to produce electrical signals. To synchronise its operation, an AT89S52 microcontroller controls the crystals. The synchronization form produced in this circuit is known as the loop of the system.

## VII. CONCLUSION

In order to monitor heart condition, the heart beat detector is mainly concerned with the identification and interpretation of heart echo signals. Which makes heart-related disease detection simpler and faster. If the instrument is used appropriately, it is extremely accurate and eliminates the margin of error as found by using other instrument such as stethoscope and stop watches. Finally, for quick interpretation, the heartbeat detector delivers performance data in English.

## REFERENCES

- [1] Sharanabasappa Sali, Pooja Durge, Monika Pokar, Namrata Kasge "Microcontroller based heart rate monitor", International Journal of Science and Research, Volume 5 Issue 5, May 2016
- [2] J. Prasath, "Wireless monitoring of Heart Rate using Microcontroller," International Journal of Advanced Research in Computer Science and Electronics Engineering (IJARCSEE), vol. 2, pp. pp: 214-219, 2013.
- [3] V. C. Ogboh, O. A. Ezechukwu, V. Akpe "An Implementation of a Heart Beat Detector Using 8051 Microcontroller" International Journal of Research in Management, Science & Technology (E-ISSN: 2321-3264) Vol. 4, No. 1, April 2016
- [4] Mr. Ved Prakash, Mr. Manoj Kumar Pandey "HEART RATE MONITORING SYSTEM" Journal of Energy Technologies and Innovative Research (JETIR) Volume 5, Issue % JETIR May 2018
- [5] Kingsley Okeoghene Enalume, Ayebatonye Marttyns Epemu "Development of a Reflectance Photoplethysmogram Based Heart Rate Monitoring Device" International Journal of Medical Imaging Vol. 5, No. 5, 2017
- [6] B. Mallick and A. K. Patro, "Heart Rate Monitoring System Using Finger Tip Through Arduino and Processing Software" International Journal of Science Engineering and Technology Research vol. 5, no. 1, 2016



10.22214/IJRASET



45.98



IMPACT FACTOR:  
7.129



IMPACT FACTOR:  
7.429



# INTERNATIONAL JOURNAL FOR RESEARCH

IN APPLIED SCIENCE & ENGINEERING TECHNOLOGY

Call : 08813907089  (24\*7 Support on Whatsapp)