



# IJRASET

International Journal For Research in  
Applied Science and Engineering Technology



---

# INTERNATIONAL JOURNAL FOR RESEARCH

IN APPLIED SCIENCE & ENGINEERING TECHNOLOGY

---

**Volume: 9      Issue: V      Month of publication: May 2021**

**DOI: <https://doi.org/10.22214/ijraset.2021.34545>**

**[www.ijraset.com](http://www.ijraset.com)**

**Call:  08813907089**

**E-mail ID: [ijraset@gmail.com](mailto:ijraset@gmail.com)**

# Indoor Air Quality Monitoring System

Abhijeet Thorat<sup>1</sup>, Diptam Paul<sup>2</sup>, Durgesh Kulkarni<sup>3</sup>, Dr. Apurva Naik<sup>4</sup>

<sup>1, 2, 3, 4</sup>School of Electronics and Communication, MIT-World Peace University, Pune, 411038, Maharashtra, India

**Abstract:** Indoor air pollution has received wide attention throughout the world for its adverse effects on humans. The main focus of this work is to present a design of an indoor air quality monitoring system to provide an accurate measurement of the air quality. Indoor air quality is a major factor to be judged and analyzed in a systematic way to be aware of the air that humans breathe in. The indoor air cleansers present are successful to some extent in purifying the air but there is no option for the users to check the continuous change in air contamination rather there is no other provision to study the long-time behavior of air they get to breathe. This paper incorporates multiple gas sensors which are used to measure the extent of the air pollutants such as MQ-2 for combustible steam, MQ-3 for alcohol, MQ-7 for carbon monoxide, MQ-9 for LPG and MQ-135 for carbon dioxide and provide with the final air quality index in a mobile application and also on a live web page. The system also provides with a simplified solution in the form of a movable device that would make users study and analyze the air both in real time and over a period of time. The pollutant concentrations would be measured thereby intimating the nearby users the danger level of the extent of some of the most harmful air contaminant concentrations.

**Keywords:** Air Quality Index (AQI); MQ gas sensor; Blynk; Parts Per Million (PPM); Cloud Platform; IoT

## I. INTRODUCTION

Indoor air pollution is main environment risk closely related to health. Approximately a human being spends average 16 hours minimum at home which is a huge time span, so at that time they are breathing “indoor air” and are exposed to indoor air pollutants which affects working performance as well as level of productivity. In this present era of industrialization, there are wide number of pollutants in the air due to this many people fall to respiratory system related diseases. By implementing the proposed system, it can monitor the air around and alert the attendee if air quality cross the critical level. It has been seen that impact of Indoor air pollution is 100 times higher that of outdoor pollutant, it is because the closed spaces promote the built-up of potential pollutants with considerably greater efficiency as compared to outdoor pollutant. Scientific community reveals that indoor air quality has been a dynamic and complex issue for modern housing arrangements in urban areas. Indoor air quality mainly degrades due to air conditioning, heating and ventilation systems, another major reason could be the usage of products which have rich chemical composition. There are approximate 2 million deaths due to indoor air contaminants making it an important issue to be addressed.

TABLE I AQI Range

RANGE	STATUS
0-50	Good
51-100	Moderate
100-150	Unhealthy for sensitive groups
151-200	Unhealthy
201-300	Very Unhealthy
301-500	Hazardous

The proposed IoT-based architecture is relevant to analyze real-time indoor air quality monitoring, having dedicated sensors to measure extent of the harmful air contaminants and providing with the accurate air quality index according to the government norms i.e., 0 to 500 as mentioned in Table 1. Additionally, the system being equipped with mobile based application makes it easy for the attendee to have a check on the air quality based on his movement.

## II. LITERATURE REVIEW

A movable air quality monitoring system is much more useful than the system whose range is defined to an extent.[1] This system simulates the user's route and provide the real time data (i.e. air quality index) and it works with Arduino's control using various sensors to detect air quality (objectifying the harmful gaseous pollutants) with the help of Zigbee wireless communications, has low power consumption, sparing points arrangement and real-time monitoring, which can obtain the air quality of users exposed to indoor life more accurately. The system gave the desired output but some of the sensors didn't provide with the approximate output value and the system was not designed to provide air quality index in standard ppm. As Arduino doesn't have its own built-in Wi-Fi module, additional ESP-01 wifi module is required making the system costly.

The live data capture for air quality is essential but the past records of the air quality is important in analyzing the traits in which it is degrading time to time.[2] Using NodeMCU which has a built-in Wi-Fi module helps to gather all the data over the cloud for analysis, and additionally the PM2.5 sensor gives us the extent of particulate matter in the air which helps in getting more accurate value of air quality index. Including a graphical user interface will help the attendee to be alert about the extent of the various air pollutants. To display the AQI on the LCD is suggested [3] this system additionally uses MQ-135 gas sensor for total AQI and dedicated MQ-6 gas sensor for detecting LPG and also has an alarm integrated to specifically alert about the LPG leakage. The system is not equipped with any mobile based application and cloud-based platform for analysis, so the system is not digitally advanced.

Wireless solution for indoor air quality monitoring has been suggested [4] The proposed solution in this paper is to measure the environmental parameters like temperature, humidity, gaseous pollutants, Particulate Matter to determine the health of environmental present in indoor. It also represents that in terms of Air Quality Index (AQI) and gives environmental information as input for controlling HVAC (Heating, Ventilation and Air Conditioning) system in a smart building. The author has developed an IoT toolkit to view the live air quality data of deployed regions in the form of numbers and graphs.

In [5] it is a central system which has multiple sensors connected to a central microcontroller (ATmega 328) and uses a 433 MHz trans-receiver. The system consists of three sensor nodes, a sink node and a PC which runs the GUI software, the sensor nodes transmit measured data every five seconds via a wireless transceiver. The carbon monoxide sensor malfunctioned in this system so it had to be replaced and there was a similar problem that the sensors didn't provide with standard ppm output values so there were extra calculations necessary to get the output in the standard units. The system developed here can serve as the monitoring component of a HVAC control system and function as an indoor air quality monitor independently.

The use of pic microcontroller PIC16F877A for the processing purpose and data is uploaded on cloud via Bolt Wi-Fi Module.

[6] If contamination level is more than the permissible limit than the graph shown on the mobile based application will turn red in color and it also starts a buzzer to alert the user. It is useful in the arrangement like universities, hospitals, warehouses where circulation of outdoor air is provided in constrained manner and even a small degradation in the quality of air may severely affect the performance of the individual residing in the area in terms of breathing troubles. The system was tested with one sensor node, it may easily adapt to include more sensing nodes.

Considering all the references, it can be noticed that most of the systems are equipped with only 2 sensors to measure all the harmful air contaminants. In the proposed system there are specific sensors dedicated to each particular harmful gas, this helps in acquiring more prominent extent of the different air contaminants thereby making the air quality index more accurate. The Node-MCU being equipped with inbuilt Wi-Fi module makes the system cheap as no external module is required to send the data to the cloud for analysis. The GUI in the system displays live extent of each of the air contaminant and air quality index. Most of the systems are acquired with warning systems with the help of buzzer, light etc. but the present system has email alerting system which makes it more efficient. Thereby the system proposed is digitally advanced and more accurate in providing output.

## III. PROPOSED SYSTEM MODEL

The unit consists of a microcontroller, analog extender and MQ series gas sensors as shown in the Figure 1. To have with an accurate value of the air quality index the proper functionality of the gas sensors is important. Hence, to detect the extent of the different air contaminants, the related system is required to use. In different changing environments, it becomes important to have a check on the air quality. So, the dedicated MQ series gas sensors are used for that purpose.

The system uses NodeMCU as the central microcontroller for the processing of the different input data from the sensors. Since NodeMCU has fewer analog pins so an analog extender ADS1115 is used for the interfacing of the analog gas sensors. The



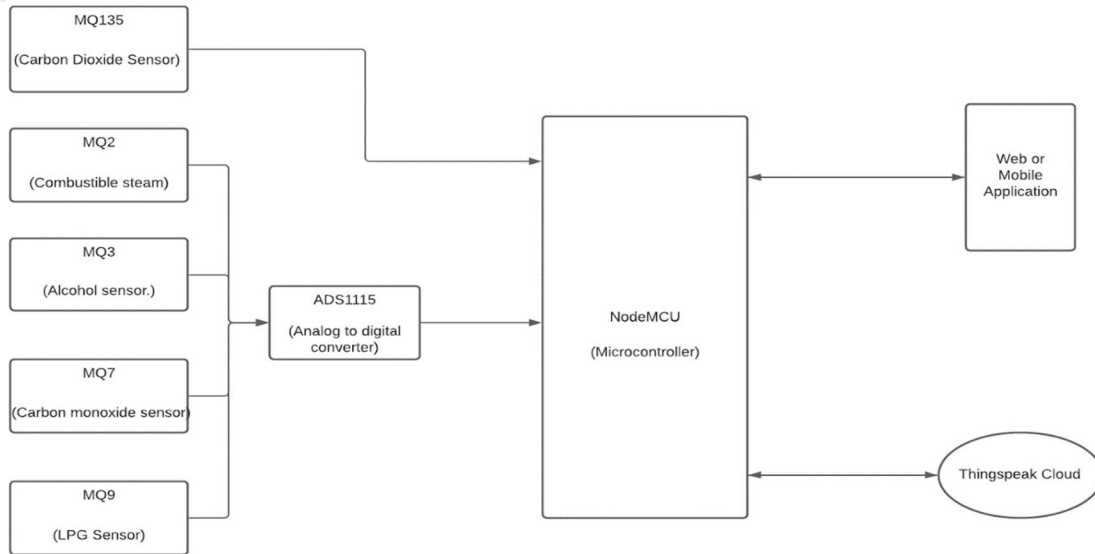

Fig. 1 System Block Diagram

MQ series sensors will provide us with the extent of the various gaseous pollutants in the environment (MQ2- flammable gases such as LPG, MQ3- ethanol, MQ7- carbon monoxide (CO) and MQ135- carbon dioxide (CO<sub>2</sub>)). MQ9 Sensor is used for sensing of LPG gas which gives more precise reading as compared to other sensors. All the inputs from the sensors will be provided to the microcontroller which in turn will calculate the air quality index according to desired formula and the final calculated result will be sent to a mobile based application or a live webpage, the developed GUI will display the extent of the desired gases and also the air quality index (AQI), it will also intimate to any nearby attendee through emails if there is LPG leakage in the indoor. The proposed system is a remotely working device on I2C and MQTT protocol based on real time data as well as it has the ability to store the real time data for further analysis. Since it's a remote device it can even provide with the air quality index of the outdoor environment. The air quality index i.e., AQI is calculated in accordance with the Ministry of Pollution Control (MPC) and for better accuracy all sensors are kept on for 24 hours to have their sensing element heat up to their accurate limit. In addition to that system can be operated manually with an on/off switch.

#### IV.HARDWARE AND SOFTWARE REQUIREMENTS

- 1) *NodeMCU*: The NodeMCU also known as ESP8266 development board for IoT applications comes with the ESP-12E module containing ESP8266 chipset having Tensilica Xtensa 32-bit LX106 RISC Architecture based microprocessor. The processor of NodeMCU works on RTOS and operates at clock frequency 80MHz to 160 MHz which is adjustable. For data and programs ESP8266 has 128 KB RAM and 4MB of Flash memory for storing purpose. It has high processing power with in-built Wi-Fi feature, it can be powered using Micro USB jack and VIN pin (External Supply Pin). It supports UART, SPI and I2C interface.
- 2) *MQ Series Gas Sensors*: The operating voltage of MQ series gas sensors is 5V, and have a lower absorption of 1 watt, absorption takes place due to the power drawn by heating element present in circuit of sensor. MQ series sensors are mainly operated in environments like extreme cold or warm, condition is that the heating filament's temperature should be kept precisely constant by its variation in resistance. But it cannot stabilize nor can be controlled by any specific circuit, hence if the environment is in extreme conditions like very cold or warm, the obtained measurement would turn out to be shifted from actual measurement. The sensing capacity of any Gas sensor depends on the chemiresistor present in it to conduct the current. The most commonly used chemiresistor is Tin Dioxide (SnO<sub>2</sub>) which is an n-type semiconductor that has free/donor electrons to make bond with positive charged particles called holes.
- 3) *ADS1115*: The ADS1115 which is our analog extender also works as Analog to Digital Converter provides 16-bit precision at 860 samples/second over I2C communication protocol. Chipset of analog extender is configured by manufacturer as 4 single-ended input channels, or two differential channels. In ADS1115 circuitry there is a programmable gain amplifier which amplifies the given input to ADC, up to x16, to help boost up both kinds of input that is smaller single/differential signals to the full range as expected. ADS1115 can work fine in 2V to 5V voltage range, can measure a large range of signals and its super easy to use because it's easy to user friendly construction. It is a great general purpose 16-bit converter.

4) *Arduino IDE*: The coding environment which is used here to develop, debug the code which is instruction set for physical microcontroller board used in proposed system is Arduino IDE (Integrated Development Environment). Arduino IDE is proved simple and robust in Arduino family board as well as ESP8266. Constant upgradation has been seen over the past few years in the Arduino IDE for advanced feature, to keep programming simple to every person even if they don't have deep knowledge about Embedded systems and new IoT applications. One can choose the software compatible with their operating system for e.g., Windows, Mac, Linux.

### V. PROCEDURE

Node-MCU development board containing ESP-8266 chip which is having Tensilica Xtensa 32-bit LX106 RISC micro- processor. For providing Wi-Fi it has inbuilt Wi-Fi module embedded in it, which helps us to store the run time data to cloud platform such as Thingspeak. Figure 2 represents ESP 8266 module, ADS1115 analog extender and MQ-2, MQ-3, MQ-7, MQ-9, MQ-135 air quality sensor. From above figure all air quality sensor are connected to 5V supply and grounded, Aout pin of all sensor is connected to A0, A1, A2, A3 pin of analog extender also known as ADC (Analog to Digital Converter).

Most important part is to calibrate sensor according to fresh air for standard outputs and form the AQI equation for generalized atmosphere, after that form the mathematical equations that converts the output voltage of sensor to the PPM (parts per million) which is the standard unit to measure concentration of gases. PPM is the ratio of one gas to another. For example, 1000 PPM of CO gas means that if you could count a million gas molecules, 1000 of them would be of carbon monoxide and 999000 molecules would be some other gases. To get PPM values from all sensor by their respective equation, find AQI (Air Quality Index by mapping to the standard range by government board.

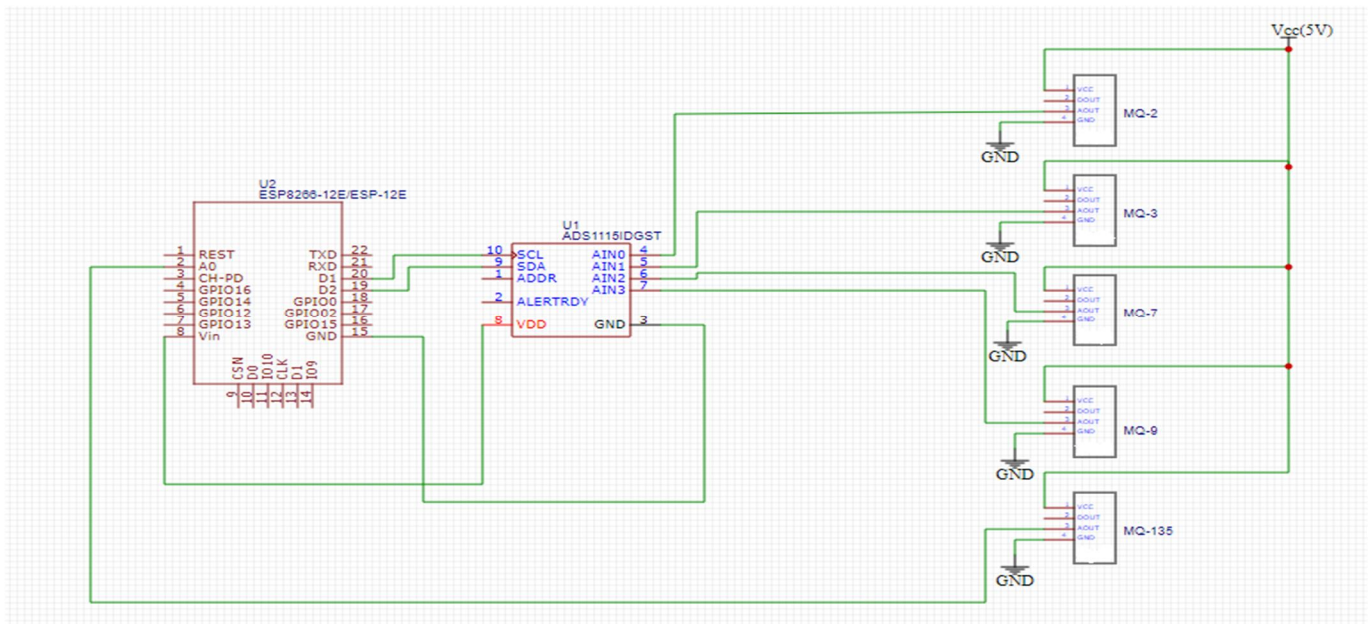

Fig. 2 System Schematic

The internal circuit diagram of MQ-2 sensor is as below, in that  $R_s$  and  $R_l$  are the resistance associated with the given sensor.  $R_s$  is the resistance of the sensor that changes depending on the concentration of gas.  $R_l$  is load resistance of sensor.

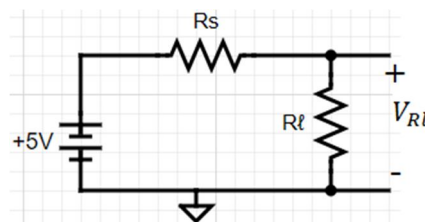

Fig. 3 Internal Circuit of MQ-2

By Ohm's Law,

$$I = \frac{V}{R} \dots \dots \dots (1)$$

But R in denominator is combination of  $R_s$  and  $R_l$  therefore eq (1) can be rewritten as

$$I = \frac{V}{R_s + R_l} \dots \dots \dots (2)$$

the output voltage can be calculated through the load resistor  $R_l$  by formula  $V=I*R$

$$V_{R_l} = \frac{V_c}{R_s + R_l} * R_l \dots \dots \dots (3)$$

$$V_{R_l} = \frac{V_c * R_l}{R_s + R_l} \dots \dots \dots (4)$$

So, this equation can be solved for  $R_s$

$$V_{R_l} * (R_s + R_l) = V_c * R_l \dots \dots \dots (5)$$

$$(V_{R_l} * R_s) + (V_{R_l} * R_l) = V_c * R_l \dots \dots \dots (6)$$

$$V_{R_l} * R_s = (V_c * R_l) - (V_{R_l} * R_l) \dots \dots \dots (7)$$

$$R_s = \frac{(V_c * R_l) - (V_{R_l} * R_l)}{V_{R_l}} \dots \dots \dots (8)$$

$$R_s = \frac{(V_c * R_l)}{V_{R_l}} - R_l \dots \dots \dots (9)$$

Eq (9) will help us find the internal sensor resistance for fresh air. Graph shows the concentration of particular gas in parts per million (ppm) versus resistance ratio of the sensor  $R_s/R_0$ .

Where  $R_s$  is the resistance of the sensor that changes depending upon concentration of gas.

And  $R_0$  is the resistance of the sensor at known concentration without presence of other gases, or in the air.

$$\frac{R_s}{R_0} = 9.8 \dots \dots \dots (10)$$

The value of  $R_s/R_0$  mentioned in the above equation is derived from sensitivity characteristics mentioned in datasheet of MQ-2 sensor. To calculate  $R_0$ , for that  $R_s$  first should be calculated in fresh air. The sensor gives analog values & by taking mean overall which is further converted into voltages. Then use  $R_s$  formula to find  $R_0$ . From the datasheet equation can be derived which relates  $R_s/R_0$  ratio with the ppm concentration. By seeing the sensitivity characteristics, linear equation for establishing primary relations can be formed, but actually the  $R_s/R_0$  to gas concentration ratio is inversely as all values mentioned on graph was in log scale.

$V_{in} = 5V$ ;

$R_l = 10k \text{ ohm}$

$V_{out}$  is the analog voltage reading from sensor

$$R_s = [(V_{in} * R_l) / V_{out}] - R_l$$

, For simplification, we can omit  $R_l$

$$R_s = (V_{in} - V_{out}) / V_{out}$$

From the above figure the linear relationship can be seen by just seeing any slant line on graph is

$$y = mx + b \dots \dots \dots (11)$$

But sensitivity characteristics are in log scale because of inverse proportion in y-axis and x-axis.

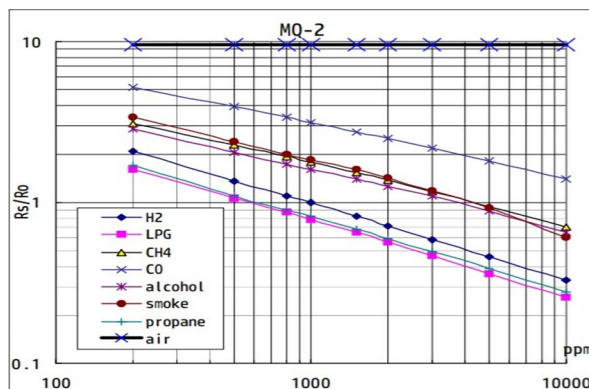

Fig. 4 MQ-2 Sensitivity Characteristics

For log scale equation 11 will be:

$$\log_{10}(y) = m * \log_{10}(x) + b \quad (12)$$

In the system MQ-2 sensor is used for smoke detection i.e., Combustible Steam

So, for finding slope take 2 points from smoke line from graph that are (200,2.6) and (10000,0.6), formula to calculate m is following:

$$m = \frac{\log(y) - \log(y_0)}{\log(x) - \log(x_0)} \dots \dots \dots (13)$$

$$m = \frac{\log\left(\frac{y}{y_0}\right)}{\log\left(\frac{x}{x_0}\right)} \dots \dots \dots (14)$$

$$m = -0.3757 \dots \dots \dots (16)$$

Now from the value of m the value of Y-intercept for can be derived for that choose one point from graph of smoke line lets say (800,2)

$$\log(y) = m * \log(x) + b \dots \dots \dots (17)$$

$$b = \log(y) - m * \log(x) \dots \dots \dots (18)$$

$$b = \log(2) - (-0.3757) * \log(800) \dots \dots \dots (19)$$

$$b = 1.391 \dots \dots \dots (20)$$

By equation (16) and (20) the values of m & b are calculated, from this gas concentration for any ratio can be derived with formula:

$$\log(x) = [\log(y) - b] / m \dots \dots \dots (21)$$

However, the concentration of particular gas can derive by taking antilog of equation (21)

$$x = 10^{([\log(y) - b] / m)} \dots \dots \dots (22)$$

By applying this calibration technique to all sensor which have been applied to this MQ-2 sensor, the following values have been mentioned in Table 2

Table II. Sensor Calibration

Sensor	$R_s/R_0$	m	b
MQ-2	9.8	-0.3757	1.391
MQ-3	60	-0.754	1.996
MQ-7	11.8	-0.6594	1.30
MQ-9	10	-0.461	1.38
MQ-135	3.6	-0.318	1.13

Using equation (9) and (22) the sensor output is converted into PPM (parts per million). All 5-sensor output will be in standard calibrated form in PPM. For finding AQI (Air Quality Index), this output collectively mapped to the range of 500 which is standard provided by Central Pollution Control Board under Ministry of Environment, Forest and Climate change, Government of India. Now the code has been developed and flashed into ESP8266 giving proper connections.

## VI. RESULTS

Graphical representation of collected AQI is shown in figure 5 contains the AQI in ordinate and Time on abscissa, graph shows the variation based on values which we have collected from sensors further stored in Thingspeak cloud. This Figure 5 shows the graph is changing high to low with respect to quantity of gas around the sensing element.

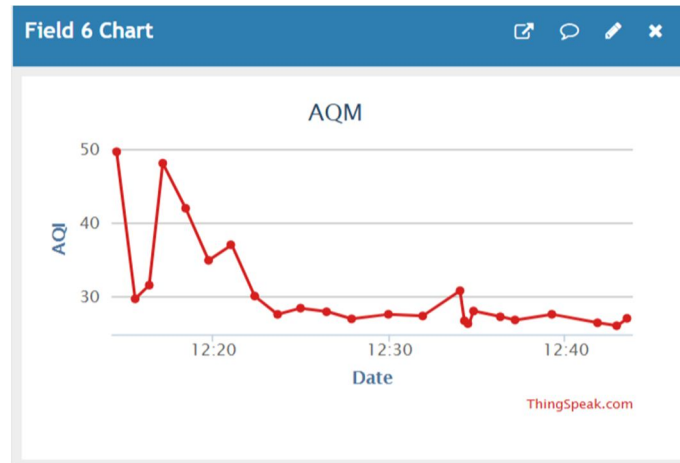

Fig. 5 Graphical Representation of Collected AQI

The android app is developed for user-friendly use, it displays the real time value from our sensors. It sends email alert to the owner of house whose mail-id is mentioned in backend code if any LPG leakage happened and further accident can be avoided. Display for the output is shown in figure 6. The display is remotely controlled at back-end by software code written with ESP8266.

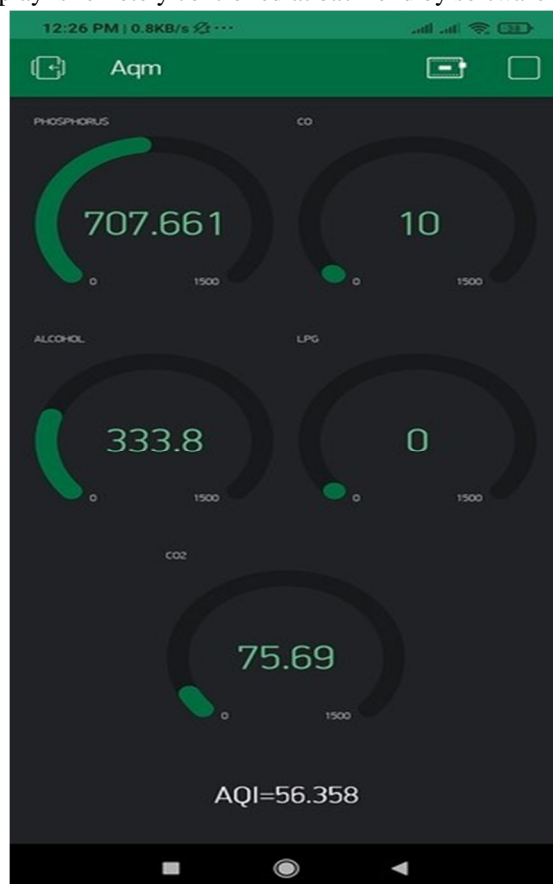

Fig. 6 Blynk App



Proposed system is also connected with web page which is built using HTML, CSS, JavaScript for better user interface. Users not having Blynk app can use web interface to get AQI readings from system will show the final AQI in gauge representation. Web interface in Figure 7 will show the real time AQI directly fetched from ESP8266. The gauge present in the webpage will indicate the level of intensity for the AQI which is decided by Ministry of Pollution Control (MPC). The refresh button present in the webpage will restart the webpage for the user.



Fig. 7 Web Interface of AQI

The analysis of the sensor data is done using Jupyter notebook in anaconda navigator. The sensor data was collected in Thingspeak cloud which was uploaded by the system for 70 days. For applying any model, the data pre-processing is necessary. Because of that it is necessary to parse the data and convert it into a format that is suitable for machine learning models.

The Figure 8 shows the correlation of the parameters in the dataset. This heatmap helps us to identify various factors that are majorly affecting AQI. From the heatmap it can be said that major factor that is affecting AQI are combustible steam/phosphorus and CO. The factors which are least affecting AQI are LPG, Alcohol, CO2.

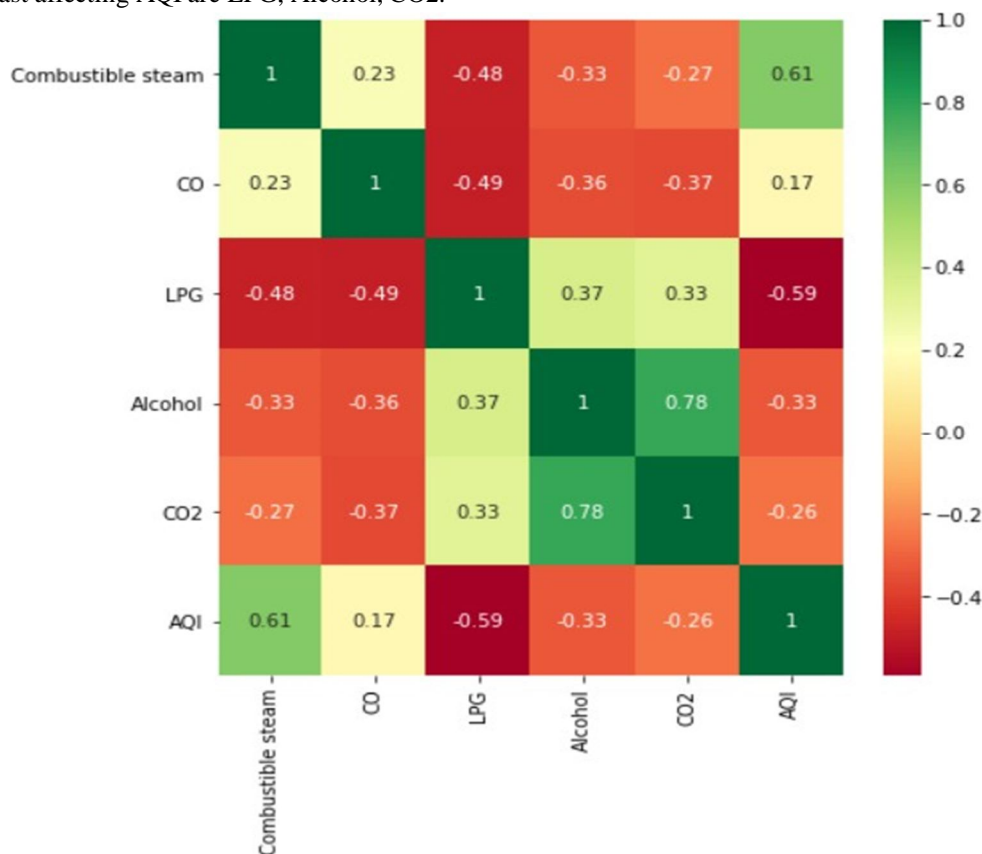

Fig. 8 Heatmap for datasets

From the plot shown in Figure 9 the data of maximum AQI on a particular day is pointed over period of time. This is done by selecting the maximum value of AQI on a particular day. Over the period of time the maximum value of AQI in indoors are high on some days but varied a lot initially. It can be seen that AQI value is within the limit set by Table 1. It will vary according to city. The values shown in figure 9 are recorded in city of Pune during time span of January 21 to March 31.

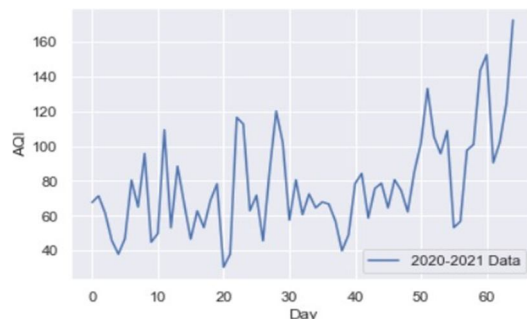

Fig. 9 Graphical Representation of Max AQI over time period of 70 Days

## VII. CONCLUSION

From all the above information provided, calculation of air quality in standard AQI is acquired. Dedicated sensors are used for measurement of different air contaminants such as combustible steam, carbon dioxide, carbon monoxide, alcohol and LPG. This paper uses correct method for PPM calculations. The system is found to be effective in indoor as well as outdoor condition. The system can be made compact so that it will be easily carried away for outdoor purpose and air quality of a particular targeted area can be monitored. As it being a remote device it can be used for outdoor purpose. For accurate calibrating, each sensor has been switched on for 24 hours to heat its sensing filament and get accurate results. Analysis also done on the data collected by sensors over 70 days which is further uploaded to Thingspeak cloud, derived the relation of AQI with respect to time and with the help of this decided the major impacting factors on AQI are LPG, Alcohol and CO<sub>2</sub>.

## REFERENCES

- [1] Liu Peng, Fu Danni, Jiang Shengqian and Wang Mingjie(2017). A Movable Indoor Air Quality Monitoring System. International Conference on Cybernetics,Robotics and Control
- [2] Ravi Kishore Kodilil and Sasweth C. Rajanarayanan (2019). IoT Based Air Quality Monitoring System. IEEE R10. Humanitarian Technology Conference (R10-HTC)
- [3] Harsh N Shah, Zishan Khan,Abbas Ali Merchant, Moin Moghal (2018). IOT Based Air Pollution Monitoring System. International Journal of Scientific & Engineering Research Volume 9, Issue 2
- [4] Sayantani Bhattacharya, Sridevi S, Pitchiah R.(2012). Indoor Air Quality Monitoring using Wireless Sensor Network. IEEE International Conference on Sensing Technology, ICST
- [5] R du Plessis, A Kumar, GP Hancke and BJ Silva. (2016). A Wireless System for Indoor Air Quality Monitoring. IEEE Annual Conference of Industrial Electronics Society
- [6] Sumita Mishra and Pallavi Asthana.(2018) IoT Enabled Real Time Bolt based Indoor Air Quality Monitoring System. International Conference on Computational and Characterization Techniques in Engineering & Sciences(CCTES)
- [7] Kinnera Bharath (2016). IoT based Air Quality monitoring system using MQ135 & MQ7 with Machine Learning analysis. Scalable Computing: Practise and Experiences
- [8] <https://www.sparkfun.com/datasheets/Sensors/Biometric/MQ-7.pdf>.



10.22214/IJRASET



45.98



IMPACT FACTOR:  
7.129



IMPACT FACTOR:  
7.429



# INTERNATIONAL JOURNAL FOR RESEARCH

IN APPLIED SCIENCE & ENGINEERING TECHNOLOGY

Call : 08813907089  (24\*7 Support on Whatsapp)