



IJRASET

International Journal For Research in
Applied Science and Engineering Technology



INTERNATIONAL JOURNAL FOR RESEARCH

IN APPLIED SCIENCE & ENGINEERING TECHNOLOGY

Volume: 9 Issue: V Month of publication: May 2021

DOI: <https://doi.org/10.22214/ijraset.2021.34605>

www.ijraset.com

Call:  08813907089

E-mail ID: ijraset@gmail.com

Automation by CAM in Punching Press Machine

Premshanker. R. Tripathi

Lecturer, Mechanical Maintenance Department, Shri T.P. Bhatia College of Science, Kandivli, India

Abstract: *From time immemorial, man has striven to achieve perfection. This thought has led him to make significant development in any stream that has come across him. One such stream is engineering. Many researches have been done to improve quality at faster production rate. The casual observer seldom takes any interest in it's development. The result of the development in Engg field has led to production and fabrication of press. These press forms a backbone in stamping industries. This technology of efficient dies to produce work piece at faster rate, at lower cost has emerged to such a degree that we can raise our present standard of living, to these dies. In anything used by us, in various field of life has been a product of these dies. This product has merged so much with our life, that it is literally impossible to eradicate or stop usage of these products. The following report is sincere effort to study the basic dies in details. The casual observer seldom takes a second look at the press department when he visits a modern production plant. He views this section of the plant as an assemblage of noisy mechanical monsters calmly chomping out parts from a roll of rubber and is much more concerned with latest machining and manufacturing process. This chapter is intended to acquaint the student or beginner with cutting operation. The design of cutting dies will be discuss in details.*

I. INTRODUCTION

Today world required speed in each and every field. Hence rapidness and quick working is most important. Now days for achieving rapidness, various machines and the equipments are being manufactured. In such a modern era of liberization, small-scale industries are contributing in a big way to the growth of our country. The engineer is constantly conformed to the challenges of bringing ideas and design into reality. New machines and techniques are being developed continuously to manufacture various products at cheaper rates and high quality. Taking into account the above contribution we have tried to help the small scale industry by introducing a machine which will be very much helpful for them intending to make a light weight and multipurpose machine. Hence we tried our hands on "AUTOMATION BY CAM"

A. Introduction about Press working

Press working is the probably the earliest occupation known to mankind. Native metals have been formed technological and shaped 7000 years ago. Press working industry utilize million on man, production tool, forming processes, building and other related facilities, in order to form and produce the material to meet the increased demand of mankind. The high productivity of forming process, the simplicity of press operation, all leads to greater extension of this method manufacturing. Of course, the many alternative processes require the complementary tooling, while in the forming dies or press tools the trouble has often been traced to an adequate grasp of the basis of design construction. Press tools processes in which they are used in an inadequate grasp on the basis of design and construction are greatly improved of lathe both in design and in regards to capacity. Press working may be defined as the chinless mfg. process by which various components are made from sheet. These processes are also termed as cold stamping. The machine used for press working is called press.

II. OBJECTIVES OF STUDY

- A. We are able to have market survey of raw material and finished product.
- B. We can actually implement practical procedure for manufacturing different components.
- C. We are known with the concept of alignments which is part of metrology.
- D. We are able to specify the machine.
- E. We are able to calculate the quantity of the material required.
- F. We could plan a manufacturing process.
- G. We are known with process chart.
- H. We can design the shafts and gear.
- I. We are able to co-ordinate the activities.
- J. We could have time study and cost estimation.
- K. We could implement the drawings for manufacturing processes.

III. WORKING OF MACHINE

The prime mover is main motor. The motor transmit power & speed to in put of gear box. Gear box increase the power by means of decreasing rpm of motor. Further torque is increase by belt & pulley arrangement .The big pulley transmit power & revolution to main shaft on main shaft cam at different position is mounted .The die is placed below T shape shank give reciprocating motion to punch & die set.

In this assembly two die are used further increasing the cam number of die can be implemented. Feeding of strip is done by feeder mounted in front of each die,

The assembly is made such that in the half revolution of shaft cam “B” & “C” will operate the feeder to feed the raw material and other half revolution of shaft cam “A” & “D” will operate die. In this way one revolution of shaft will perform four operations.

IV. WORKING PRINCIPLE OF DIE

The strip of sheet metal is fed and guided through a slot in the stock guide or a slot in the stripper plate. After each blanking, the strip has to be advanced a correct distance. The device used to achieve this is called stock stop. The simplest arrangement may be a dowel pin or a small block against which an edge of the previously blanked hole is pushed. After each stroke of the press on it's upward stroke the punch carried the stock strip gets released from the stop with constant pressure exerted pushing the stock strip to the left, the stock will move as it is lifted clear, then drop with the next hole over the stop as the scrap strip stripped from the punch. This type of stock stop is suitable for only low and medium production dies, since the operator has to force the stock over the shielded to secure a desired feed length.

V. FUNDAMENTALS OF CAM

A cam is a device used to convert a constant velocity rotary motion into a reciprocating motion which has the kinematics features that we desire. (Reciprocating means "back and forth" or "up and down" in this case.) A common application of the cam is in the engine of a car. A rotating cam shaft is used to cause the valves in the engine to move up and down. Here is a two dimensional picture of a cam mounted on its shaft, and contacting its follower.

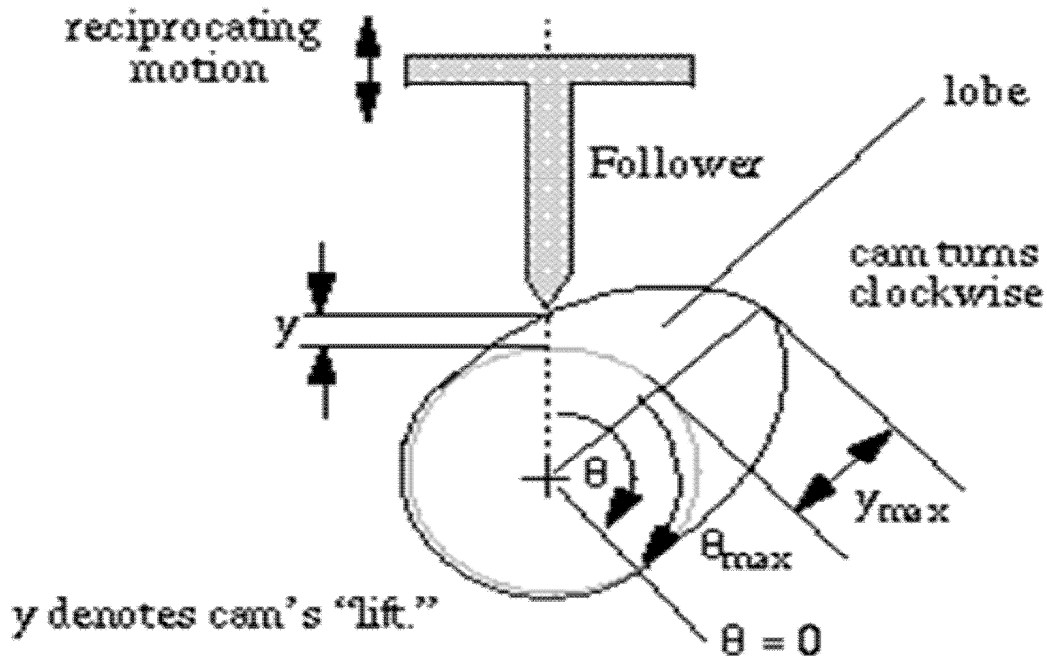

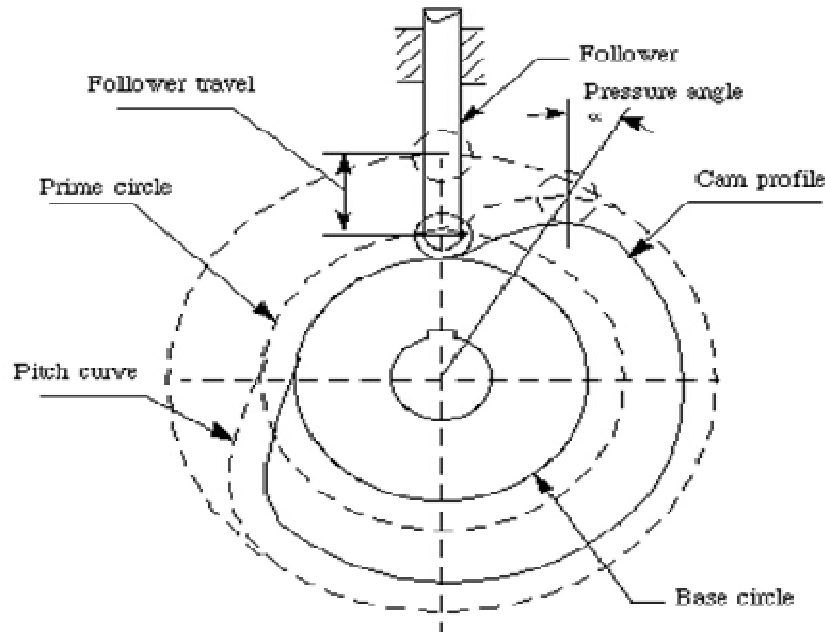

A. Cam nomenclature

- 1) **Trace Point:** A theoretical point on the follower, corresponding to the point of a fictitious knife-edge follower. It is used to generate the pitch curve. In the case of a roller follower, the trace point is at the center of the roller.
- 2) **Pitch Curve:** The path generated by the trace point at the follower is rotated about a stationary cam.
- 3) **Working curve:** The working surface of a cam in contact with the follower. For the knife-edge follower of the plate cam, the pitch curve and the working curves coincide. In a close or grooved cam there is an inner profile and an outer working curve.
- 4) **Pitch Circle:** A circle from the cam center through the pitch point. The pitch circle radius is used to calculate a cam of minimum size for a given pressure angle.
- 5) **Prime Circle (Reference Circle):** The smallest circle from the cam center through the pitch curve.
- 6) **Base Circle:** The smallest circle from the cam center through the cam profile curve.
- 7) **Stroke or Throw:** The greatest distance or angle through which the follower moves or rotates.
- 8) **Follower Displacement:** The position of the follower from a specific zero or rest position (usually its the position when the follower contacts with the base circle of the cam) in relation to time or the rotary angle of the cam.
- 9) **Pressure Angle:** The angle at any point between the normal to the pitch curve and the instantaneous direction of the follower motion. This angle is important in cam design because it represents the steepness of the cam profile.

The difference between the radius at the point of contact and the radius of the cam's base circle (shown in lighter color in the figure) is called the lift. It is the linear displacement of the follower in the case shown. The lift is an important feature of the design. In this case, a significant portion of the cycle the cam's surface and the base circle coincide. This is called a dwell. So, in the case shown, we have a dwell at zero lift. Here is a plot of the lift as a function of rotation angle q .

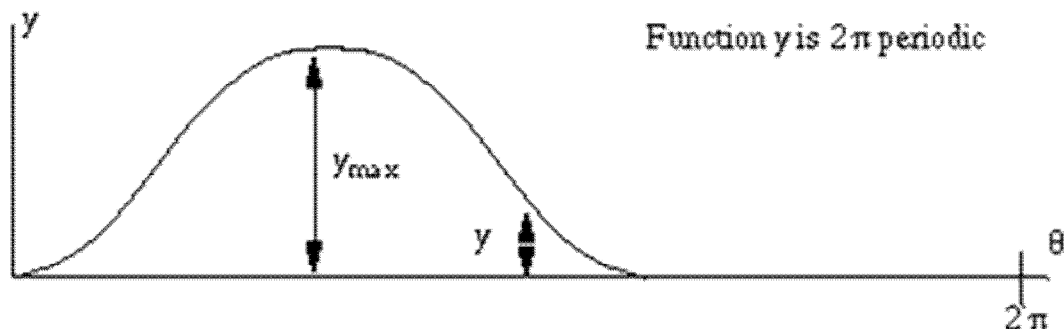

The lift function is a displacement. Its first derivative can be used to compute the velocity, v , and the acceleration, a , of the follower. If w is the angular velocity in radians per second of the camshaft, then $v = w y'$ and $a = w^2 y''$. There is a third derivative quantity the "jerk" which is the time derivative of acceleration, $j = w^3 y'''$. The jerk is the time rate of change of acceleration. The larger its value, the more likely the cam is to create undesirable vibrations in the engine.

Have you ever looked closely at a simple mechanical toy ? If you have the opportunity to study one closely you will see that it is made up of mechanisms, usually including CAMS.

Can you name any mechanical devices that use cams as part of its movement?

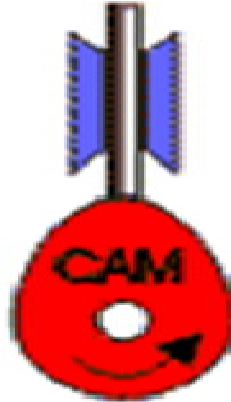

A CAM changes the input motion, which is usually rotary motion (a rotating motion), to a reciprocating motion of the follower. They are found in many machines and toys

A CAM has two parts, the FOLLOWER and the CAM PROFILE. Diagrams one to six show a rotating cam pushing a follower up and then allowing it to slowly fall back down.

VI. SELECTION OF MATERIAL

To prepare any machine part, the type of material should be properly selected, considering design, safety and following points:-

The selection of material for engineering application is given by the following factors:-

- 1) Availability of materials.
- 2) Suitability of the material for the required components.
- 3) Suitability of the material for the desired working conditions.
- 4) Cost of the materials.

In addition to the above factors the other properties to be considered while selecting the material are as follows :-

A. Physical Properties

These properties are colour, shape, density, thermal conductivity, electrical conductivity, melting point etc.

B. Mechanical Properties

The properties are associated with the ability of the material to resist the mechanical forces and load. The various properties are:-

- 1) *Strength*: It is the property of material due to which it can resist the external forces without breaking or yielding.
- 2) *Stiffness*: It is the ability of material to withstand the deformation under stress.
- 3) *Ductility*: It is the property of material due to which it can be drawn into wires under a tensile load.
- 4) *Malleability*: It is the property of material which enables it to be rolled into sheets.
- 5) *Brittleness*: It is the property of material due to which it breaks into pieces with little deformation.
- 6) *Hardness*: It is the property of material to resist wear, deformation and the ability to cut another material.
- 7) *Resilience*: It is the ability of the material to store energy and resist the shock and impact loads.
- 8) *Creep*: It is the slow and permanent deformation induced in a part subjected to a constant stress at high temperature.

We have selected the material considering the above factors and also as per the availability of the material. The materials which covers most of the above properties are

C. Mild Steel

- 1) **Composition:** Carbon 0.20 % - 0.30% Manganese 0.30% - 0.60%
- 2) **Properties:** Tensile strength 44.54 kgf/mm²
 Yield stress 28 kgf/mm²
 Hardness 170 BHN\
- 3) **Uses:** General purpose steels for low stressed components.

VII.CAM PROFILES

Cams can be shaped in any number of ways and this is determined by the way the follower is to move. The shape of the cam is called the PROFILE. Examples of various cam profiles can be seen below.

PEAR	CIRCULAR	HEART	DROP
Pear shaped cams are used on the shafts of cars. The follower remains motionless for about half of the cycle of the cam and during the second half it rises and falls.	Circular cams or eccentric cams produce a smooth motion. These cams are used in steam engines.	Heart shaped cams allow the follower to rise and fall with 'uniform' velocity.	What type of movement do you think this cam profile will give ?

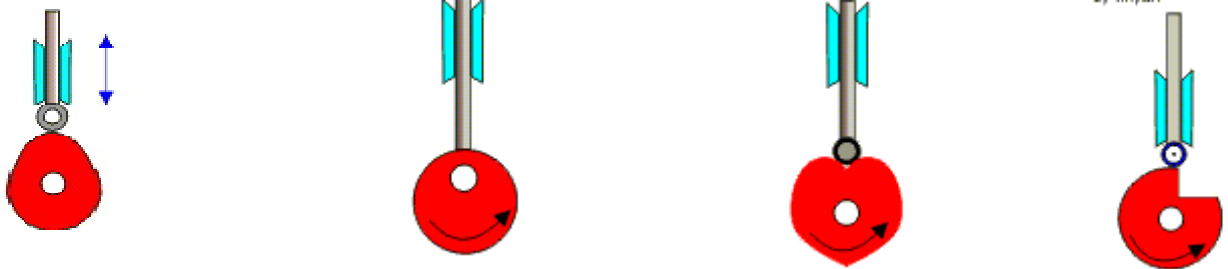

- 1) **The Cylindrical Cam / Barrel Cam:** As the cylinder cam profile rotates the follower moves upwards. When the follower reaches the top, the cylinder cam rotates in the opposite direction and follower moves back down.

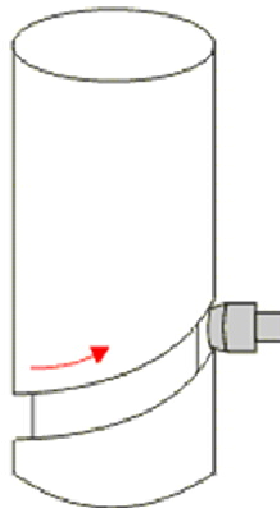

These unusual cams are normally composed of a cylinder which has a groove cut out of its surface and it is in this that the follower runs up and down. This type of cam can be seen in some old clock mechanisms and still in modern sewing machines. Machines that perform repetitive movements may use a cylinder cam profile.

- 2) *The Flat Plate Cam / Linear Cam:* As the flat plate cam profile moves to the left the follower drops down the slope and then eventually rises up at the other end. The flat plate cam then reverses in the opposite direction and the follower drops and rises again.

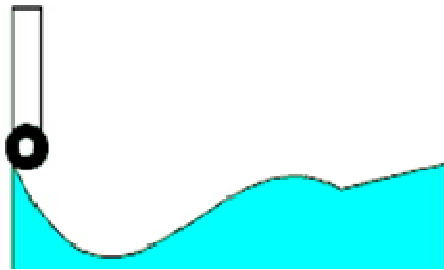

The edge of the flat plate cam can be shaped to give different vertical movements of the cam follower. Flat plate cams or linear cams as they are often called are used frequently in machines which carry out the same repetitive movements.

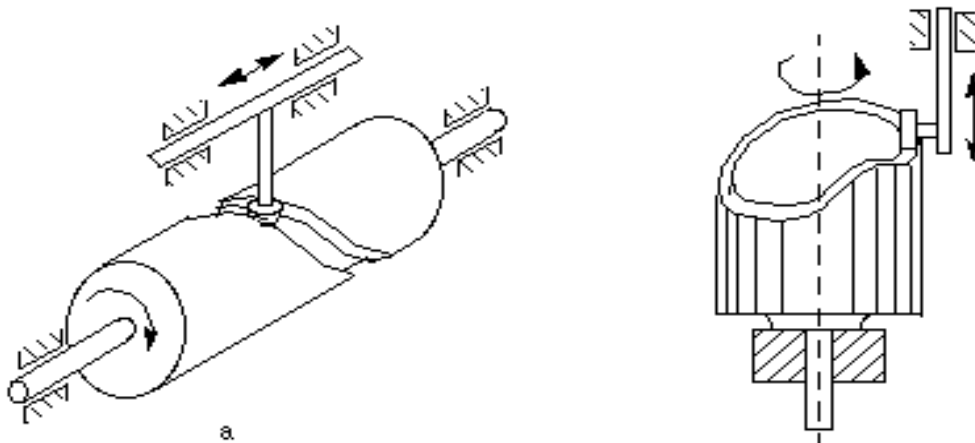

VIII. CONCLUSION

Therefore on comparing the existing process and the automation by cam process, we can conclude that by automising press working operations we can increase the productivity in order to meet the market demands also reducing the time for producing a number of products at a time in turn reducing the cost and thus achieving maximum profit.

REFERENCES

- [1] P.M.Pradhan, "Experimental Investigation and Fabrication of Pneumatic Punch", International Journal of Innovative Research in Science, Engineering and Technology, Vol. 2, Issue 6, June 2013.
- [2] A.S. Aditya Polapragada & K. Sri Varsha, "Pneumatic Auto Feed Punching and Riveting Machine", International Journal of Engineering Research & Technology (IJERT) Vol. 1 Issue 7, September – 2012 ISSN:2278-0181.
- [3] U.P. Singh, "Design Study of the Geometry of a Punching tool", Journal of Materials Processing Technology, 33 (1992) 331-345 Elsevier.
- [4] P.C.Sharma, "Methods of reducing Cutting Forces", Pages 63-66, Production Engineering, Ninth edition, 2004, S. Chand & Company Ltd.
- [5] E. Paul. Degarmo, "Shearing in Metal Cutting", Pages 518-528, Materials and Processes in Manufacturing, Eighth edition, 2003, Prentice Hall of India Pvt Ltd.
- [6] K. Mahadevan, Design Data Handbook, Third edition, Reprint 2002, CBS Publishers & distributors.



10.22214/IJRASET



45.98



IMPACT FACTOR:
7.129



IMPACT FACTOR:
7.429



INTERNATIONAL JOURNAL FOR RESEARCH

IN APPLIED SCIENCE & ENGINEERING TECHNOLOGY

Call : 08813907089  (24*7 Support on Whatsapp)