



# IJRASET

International Journal For Research in  
Applied Science and Engineering Technology



---

# INTERNATIONAL JOURNAL FOR RESEARCH

IN APPLIED SCIENCE & ENGINEERING TECHNOLOGY

---

**Volume: 9      Issue: V      Month of publication: May 2021**

**DOI: <https://doi.org/10.22214/ijraset.2021.34783>**

**[www.ijraset.com](http://www.ijraset.com)**

**Call:  08813907089**

**E-mail ID: [ijraset@gmail.com](mailto:ijraset@gmail.com)**

# Solar Tracker Implementation on Proteus Software

Abhishek Gupta<sup>1</sup>, Ikshansh Vashist<sup>2</sup>, Lakshita Sharma<sup>3</sup>, Manan Jain<sup>4</sup>, Nishant Agarwal<sup>5</sup>

<sup>1, 2, 3, 4, 5</sup>Department of Electrical Engineering, Swami Keshvanand Institute of Technology, Management and Gramothan, Jaipur

**Abstract:** The demand of electrical energy is increasing on each successive day. Solar power is a great way to meet the demand. Efficient solar panels are the need of the hour. To increase the efficiency of solar panels, Solar trackers is a solution. To improve its efficiency solar tracker is the best alternative [1]. This paper provides the comparative study of the solar tracker implementation on the proteus software. The solar tracker is of two types: single axis solar tracker and the dual axis solar tracker. This paper is more focused on dual axis solar tracker as it is more efficient and provides good output power comparatively to single axis solar tracker [2].

**Keywords:** Solar panel, dual axis solar tracker, proteus software.

## I. INTRODUCTION

Global warming has increasing gradually and leads to requirement of green energy, which is generated by solar system. Therefore, solar tracking is increasingly being applied as a sustainable power generating result. Solar Tracking System is a device for orienting a solar panel or solar reflector to start following the sun throughout the day till evening [3]. The solar cell applications, require a high degree of precision to ensure that the concentrated sunlight is directed precisely to the powered device [4],[3]. The tracking of the sun is achieved by two methods: single axis and dual axis solar tracker.

## II. DUAL AXIS SOLAR TRACKER

Dual axis solar tracker has two degrees of freedom that act as axes of symmetry. The axes of dual solar tracker are accustomed normal to one another [5]. It can go round simultaneously in horizontal and vertical directions and are able to point at the sun at all times. Dual axis trackers track the sun both East to West and North to South direction for added power output (approx. 40% obtain) and expedience [4].



Fig.1 Dual axis solar tracker

## III. METHODOLOGY

LDR method have the three Light dependent resistor (LDR) which are placed on the common plate with the solar panel [3]. As the light strikes on them, due to their inherent property of decreasing resistance with increasing incident light intensity called photoconductivity. The values of resistance of all LDRs is not always same.

Every single LDR send the equivalent signal of their respective resistance value to the microcontroller which is configured by the required programming logic. The values are compared with each other by considering a particular LDR values as reference. One of the two servo motor is mechanically attached with the driving axis of the other one so that the former will move with rotation of the axle of latter one. The servo motor is used to operate a solar panel can move along X-axis as well as Y-axis [6].

Based on the input signal received from the LDRs, the microcontroller sends appropriate signal to the servo motor. Both the two servo motor is used for tracking along X-axis and Y-axis respectively.

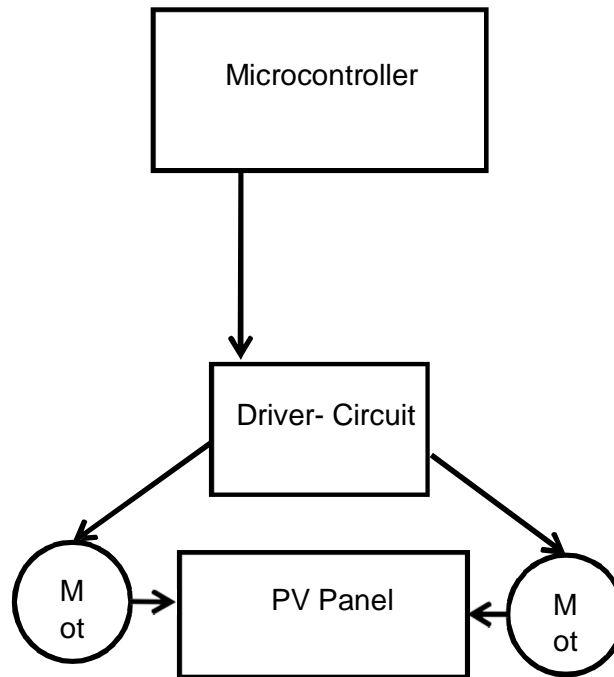

Fig.2 Block diagram of solar tracker

**A. Simulation**

Simulation of solar tracker is implemented on the Proteus professional software [2]. The proteus software is used by engineers and technicians to create schematics and electronic prints for manufacturing printed circuit boards [6]. All the required components are taken from the library of proteus software.

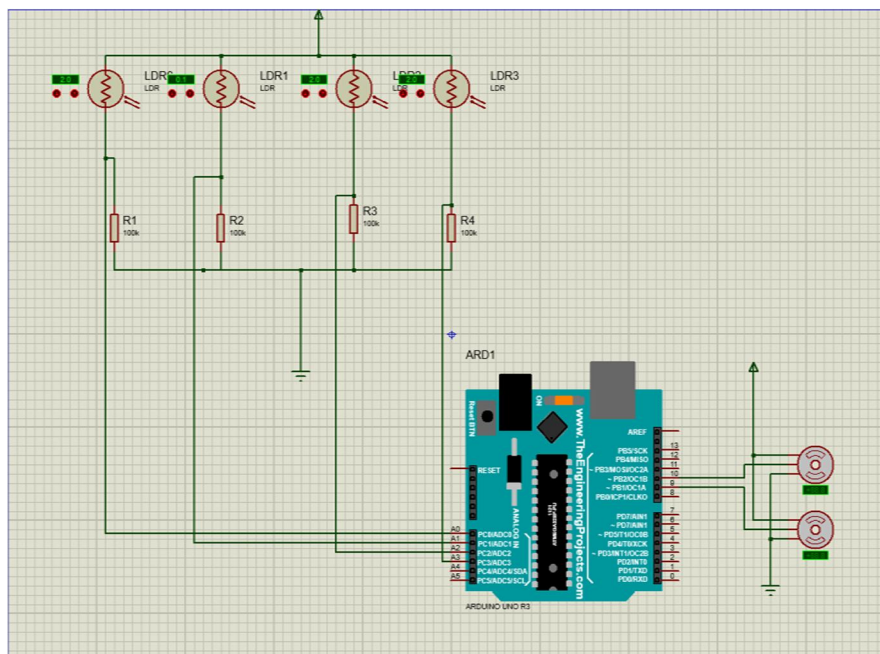

Fig3. Simulation circuit diagram of solar tracker

### B. Arduino Coding

```
#include <Servo.h>

//defining Servos Servo servohori; int servoh = 0;
int servohLimitHigh = 160; int servohLimitLow = 20; Servo servoverti;

int servov = 0;

int servovLimitHigh = 160; int servovLimitLow = 20;

//Assigning LDRs
int ldrtopl = 2; //top left LDR green int ldrtopr = 1; //top right LDR yellow int ldrbotl = 3; // bottom left LDR blue
int ldrbotr = 0; // bottom right LDR orange
void setup ()
{
  servohori.attach(10); servohori.write(0); servoverti.attach(9); servoverti.write(0); delay(500);
}

void loop()
{
  servoh = servohori.read(); servov = servoverti.read();
  //capturing analog values of each LDR int topl = analogRead(ldrtopl);
  int topr = analogRead(ldrtopr); int botl = analogRead(ldrbotl); int botr = analogRead(ldrbotr);
  // calculating average

  int avgtop = (topl + topr) / 2; //average of top LDRs

  int avgbot = (botl + botr) / 2; //average of bottom LDRs

  int avgleft = (topl + botl) / 2; //average of left LDRs

  int avgright = (topr + botr) / 2; //average of right LDRs
  if (avgtop < avgbot)
  {
    servoverti.write(servov + 1); if (servov > servovLimitHigh)
    {
      servov = servovLimitHigh;
    }
    delay(10);
  }
  else if (avgbot < avgtop)
  {
    servoverti.write(servov - 1); if (servov < servovLimitLow)
    {
```



```
servov = servovLimitLow;
}
delay(10);
}
else
{
servoverti.write(servov);
}
if (avgleft > avgright)
{
servohori.write(servoh +1); if (servoh > servohLimitHigh)
{
servoh = servohLimitHigh;
}
delay(10);
}
else if (avgright > avgleft)
{
servohori.write(servoh -1); if (servoh < servohLimitLow)
{
servoh = servohLimitLow;
}
delay(10);
}
else
{
servohori.write(servoh);
}
delay(50);
}
```

#### IV. RESULT

Energy injected by the system into the grid is 3250.2 kWh/year.

	E_Grid kWh
January	270.0
February	286.3
March	324.6
April	306.6
May	305.5
June	261.1
July	227.2
August	210.3
September	254.9
October	282.5
November	252.8
December	268.4
Year	3250.2

Fig4. Simulation result

#### V. CONCLUSION

With Global Warming constantly affecting the world in numerous ways, it is crucial we begin taking care of nature in whatever way possible. The tracking system is the most beneficial method to built a clean and green environment. From the study and the observation the dual solar tracker produce 40% more energy as compare to fixed solar panel [4],[3]. Enhancing the solar powered systems with dual trackers proves to be the optimal solution for utilizing the available solar energy.

#### REFERENCES

- [1] J. C. A. Y. Rizk and Y. Chaiko, "Solar tracking system: more efficient use of solar panels", World Academy of Science, 2008.
- [2] Richard Eberechi Echendu, Hachimenum Nyebuchi Amadi, "Design and Implementation of an Off-Grid Solar Tracker Control System using Proteus Version 8.1" Volume 8, Issue 4, April 2018, ISSN 2250-3021.
- [3] Qi-Xun Zhang, Hai-Ye Yu, Qiu-Yuan Zhang, Zhong-Yuan Zhang, Cheng-Hui Shao and Di Yang, Energies 2015, "A Solar Automatic Tracking System that Generates Power for Lighting Greenhouses", 8, 7367-7380; doi:10.3390/en8077367.
- [4] "Solar Tracking System", Reshmi Banerjee, International Journal of Scientific and Research Publications, Volume 5, Issue 3, March 2015, ISSN 2250-3153.
- [5] B. S. Kumar and K. Sudhakar, "Performance evaluation of 10 MW grid connected solar photovoltaic power plant in India," Energy Reports, vol. 1, pp. 184–192, 2015.
- [6] "Design and implementation of smart electronic solar tracker based on Arduino", Muthna Jasim Fadhil, Rashid Ali Fayadh, Mousa K. Wali, Volume 17, 5, October 2019, pp.2486~2496.



10.22214/IJRASET



45.98



IMPACT FACTOR:  
7.129



IMPACT FACTOR:  
7.429



# INTERNATIONAL JOURNAL FOR RESEARCH

IN APPLIED SCIENCE & ENGINEERING TECHNOLOGY

Call : 08813907089  (24\*7 Support on Whatsapp)