



IJRASET

International Journal For Research in
Applied Science and Engineering Technology



INTERNATIONAL JOURNAL FOR RESEARCH

IN APPLIED SCIENCE & ENGINEERING TECHNOLOGY

Volume: 9 Issue: VI Month of publication: June 2021

DOI: <https://doi.org/10.22214/ijraset.2021.35001>

www.ijraset.com

Call:  08813907089

E-mail ID: ijraset@gmail.com

Design and Fabrication of Bladeless Windmill for Power Generation

Dr. Adik Yadao¹, Utkash Pawar², Akash Bhokare³, Sujit Waghmare⁴, Pankaj Pawade⁵

¹Professor, ^{2,3,4,5}Student, Department of Mechanical Engineering, G.H. Raisoni college of engineering and Management Wagholi, Pune. PIN-412207.

Abstract: The world is heading towards maximum utilization of non-conventional energy resources like solar, Biofuel, Biogas and wind energy is also a part of it. The world has set a goal of 2030 up to which use of carbon emitting fuels is to be eliminated. The method of producing wind energy is Windmill. The windmills around us nowadays are of conventional type, means, they make use of Blades and rotor to convert wind energy into power. If we the structure of conventional windmill, we came to know that it is quite expensive and also carries additional cost of its maintenance, handling, transportation, and storage with it. Due to rotating parts and the metal property to get corroded with time makes it more expensive. We are trying to eradicate this drawbacks with our concept of Bladeless windmill. Our project will completely eliminate the blades and will give power without the extra cost carrying with it.

Keywords: Bladeless windmills, drawbacks, non-conventional energy source, vortex shedding principle.

I. INTRODUCTION

Conventional windmill is used to convert wind motion into circular motion to produce power. For this purpose it makes the use of blades which rotate when wind strikes to it cause it to rotate. As the blades rotate, the shaft on which blades are mounted also rotates due to it. The shaft is further connected to the alternator and then to the generator. When the shaft rotates, the magnetic fields produced by the rotor present inside the alternator gets disturbed and electromotive force gets produced (emf), which leads to produce electric power. This power is further stored in the generator and used whenever required. This was the traditional way to produce the power until Bladeless windmill concept was introduced. But this idea originated in Spain and grabbed attention of all world towards this concept. The concept basically is based on the fluid mechanics' "Vortex Shedding Principle", that when fluid is restricted to flow through a decreasing area, eddies are formed and vortex is created and this creates a turbulence effect. This idea is applicable to this concept. In this concept, the function of blades is overtaken by this fluid concept. Instead of using blades, a convergent nozzle is used to create the vortex effect and due to turbulence formed the nozzle will start to vibrate with some amplitude. Now rest work is done by the pure mechanical arrangements. The motive now is just to convert this oscillatory motion into rotating motion, in order to produce torque required for the power generation. In earlier to this, different mechanisms have been used by many people to convert this translating motion into rotating motion. Like rack and pinion, direct connection to gear, and also by piezoelectric method. Despite of this we are going to use a pure mechanical linkage of a connecting rod and wheel to convert this motion. As in case of I.C. engine we are going to use the same mechanism in this project and will compare with previous conclusions and decide the most efficient out of them.

II. WORKING PRINCIPLE

The operating principle of the bladeless windmill is based on the natural phenomenon of vortex shedding, created by placing an unstreamlined obstacle. Vortex shedding is because of the formation of vortices due to vortex flow caused by restrictions provided by gradually reducing cross sectional area. The circular shape of the mast (frustum shape) generates a flow pattern generates a flow pattern called as Karman vortex flow. Forced vibration induced by Karman vortex shedding. Karman vortex shedding occurs due to the flow separation around the structures. The alternate shedding of vorticity behind the mast leads to periodic pressure oscillations both in the transverse and flow directions. The vortex shedding frequency is given by a dimensionless number, which is known as Strouhal number. Strouhal number depends on the object on which the flow passes over also on the velocity of the flow which is calculated by Reynold's number. Strouhal number is given by,

$$S_t = f_v * D / U$$

Where, f_v = vortex shedding frequency,

D = Outer diameter of the mast,

U = Free stream velocity

When the natural frequency of the mast matches the f_v resonance is created and the mast vibrates with larger amplitude. The increased amplitude of the mast causes increase in vibrations and thereby increases power generation capacity.

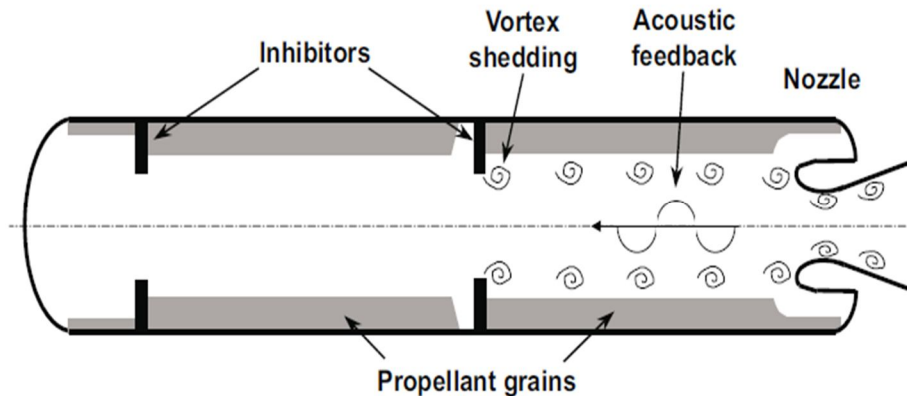

III. LITERATURE REVIEW

Gaurao Gohate, Abhilash Khairkar, Sameer Jadhav. In this paper we can study of the vortex induced vibrations for producing energy with the various methods of the wind power energy are discussed. For the generation of wind energy the various phenomenon and concepts are used is also discussed. Also the various problems in the conventional wind power harvesting are also discussed. From this paper we also understand that by using a piezoelectric material in the oscillation of wind power harvesting type model is also better way to produce electric energy .

Prof. Harshith K, Blayan Santosh Fernandes, Shreerama P R, Thilak Raj This paper deals with the theoretical study of the bladeless wind power generation. In which various detail parts of bladeless wind power generation is discussed. In this paper the assembly of sprocket, chain and wheel is attached mast model is discussed and also history of the bladeless wind power generation is to be discussed. The different applications of the bladeless windmill and its future scope are studied.

Antonio Barrero-Gila, Santiago Pindadob, Sergio Avilac , In this study, (VIV) of a circular cylinder is analyzed as a potential source for energy harvesting. To this end, VIV is described by a onedegree-of-freedom model where fluid forces are introduced from experimental data from forced vibration tests. The influence of some influencing parameters, like the mass ratio m^* or the mechanical damping ξ in the energy conversion factor is investigated.

Robert Correa, Eric Cremer: Wind harvesting via Vortex induced vibration; BJS- WD14; in this he studied that; There is a need for renewable energy source s to be more feasible. Electricity Research Article Volume 9 Issue No. 6 International Journal of Engineering Science and Computing, June 2019 22863 <http://ijesc.org/> would be collected from this oscillation using a magnet and coil assembly.

Dharampal Yadav, Haripal Dhariwa and Barun Kumar Roy, The paper is based on modification of domestic wind turbine In this work traditional wind turbines are replaced by adopting the venturimeter shaped ducted turbine by which we can increase the wind velocity about three times (09-15 m/s) which is suitable for running the generator to its rated speed (200-600 RPM) without using the gear-box. Small sized compact turbine may be constructed of throat diameter ranging between 0.5 m-01 m which can produce power from 100 W to 500 W.

Odia O. Osador1, Ososomi A. Sunday, Okokpujie I. Princes, This work focuses on the design and construction of a small wind turbine suitable for generating electricity in low wind speed regime at very low cost. In the design process,the various components of the wind turbine were considered and all the loads liable to occur during all temporary and operating conditions were calculated theoretically and the designs were optimized to ensure that the turbine operates at full capacity.

IV. PROBLEM STATEMENT

- A. The problems with the conventional windmills are discussed for the design and construction of bladeless windmills are as follows:
- B. The conventional windmills require more space due to their large construction.
- C. Cost of Production, Transportation, Maintenance and storage is high.
- D. Design of conventional windmills is complicated and handling is quiet dangerous.

V. OBJECTIVE

The uttermost objective behind this project is to make design a compact and more efficient structure so that installation becomes easier.

The main objective of our project is:

- A. Increase the efficiency by enhancing performance parameters.
- B. To provide prudent and highly effective energy.
- C. Eliminate pollution and provide clean energy.

VI. ANALYTICAL CALCULATIONS

A. Material Specification

- 1) *Glass Fiber:* Glass fiber is one of the best materials suited for the manufacturing of the Mast. It is made from certain layers of fibers, made thick and having a shiny look. It is cheap but holds excellent properties given below:
 - a) *High tensile strength:* Glass has greater tensile strength than steel wire of the same diameter; at a lower weight.
 - b) *Good Thermal Conductivity:* These fibres have good low thermal conductivity.
- 2) *Carbon Fiber:* Carbon fiber is second good material for the mast fabrication but it is good for small scale applications as is weak in fatigue loading. It is expensive than glass fiber and hence easily affordable. As the name indicates it is made from numerous layers of carbon atoms to form a thick sheet.
 - a) Highly Rigid
 - b) Excellent fatigue resistance
 - c) Favourable tensile strength
 - d) Costlier.

Sr.No.	Material	Density (g/cm ³)	Tensile Strength(Mpa)	Compressive Strength (Mpa)	Thermal Expansion
1	Glass Fiber	1.79	3445	1480	5.4
2	Carbon Fiber	2.45	4127	1600	2.9

B. Design Calculations

1) Model

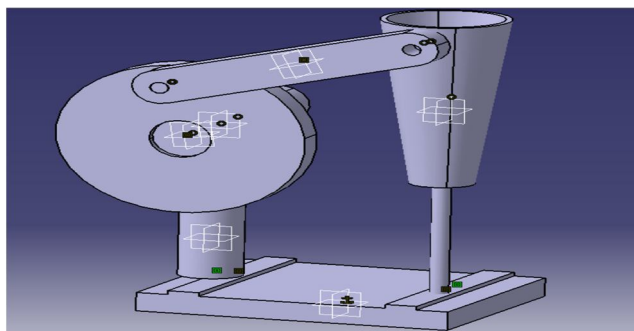

2) Components

- a) Mast
- b) Mast Support
- c) Frame
- d) Connecting link and wheel mechanism
- e) Dynamometer
- f) Bulb

Mast dimension calculation,

Assuming,

D_{max} = Upper Diameter of the mast,

D_{min} = Lower Diameter of the Mast,

D = Mean Diameter of the Mast,

d = Rod Diameter,

L1 = Mast Length,

L2 = Rod Length,

U = Free stream velocity,

$D_{mean} = (D_{max} + D_{min})/2$,

Taper Ratio = $L/(D_{mean})$,

Area of Tapered Cylinder = $(\pi/2) * (D_{max} + D_{min}) * L$

Let's Fix Length L = 1 m

$L/D = 10$

$1000/D = 10$

Sr.No.	Parameter	Dimension(mm)
1.	Dmax.	100
2.	Dmin.	60
3.	D	80
4.	L1	550
5.	L2	450
6.	L	1000

VII. RESULTS AND DISCUSSION

From the analysis we have come to know that by how much amount the mast will deflect under different loads acting over it. The size of the wheel required to complete a full rotation as per that deflection. Torque is then calculated which will be produced for a certain amount of force. And finally the number of revolutions of the dynamometer shaft per minute which will produce power of 15 W which is sufficient to light a LED lamp.

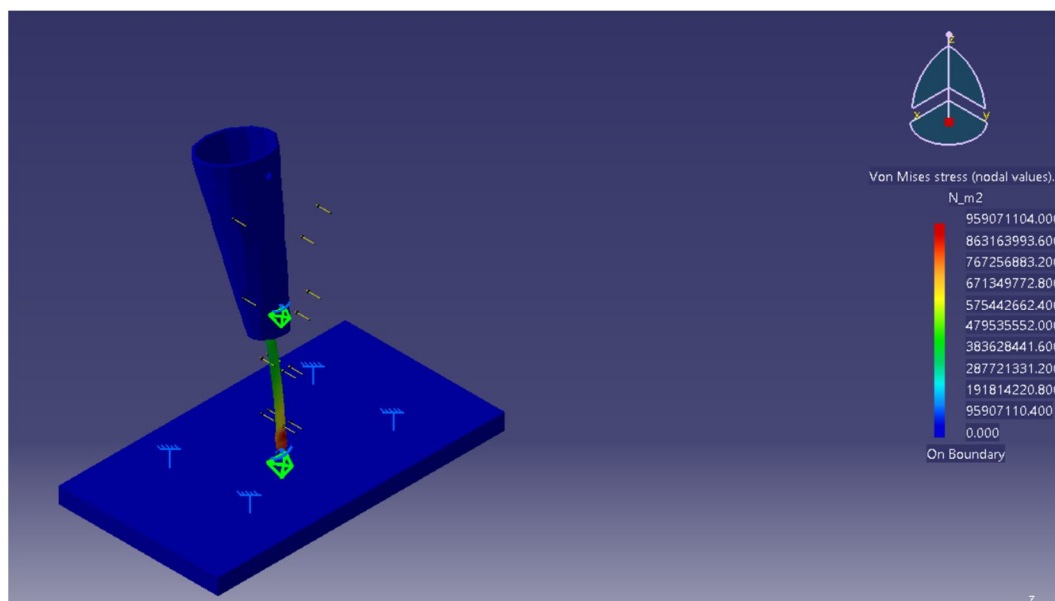

Fig. Stress Analysis of Mast

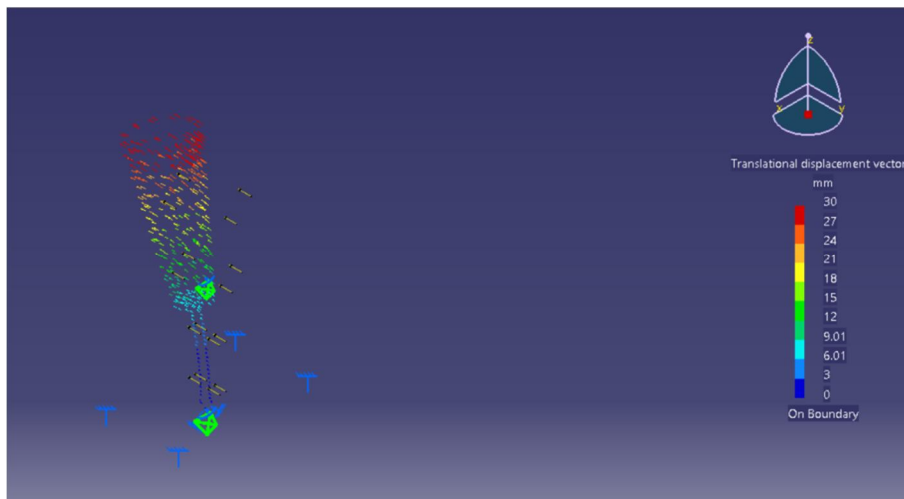
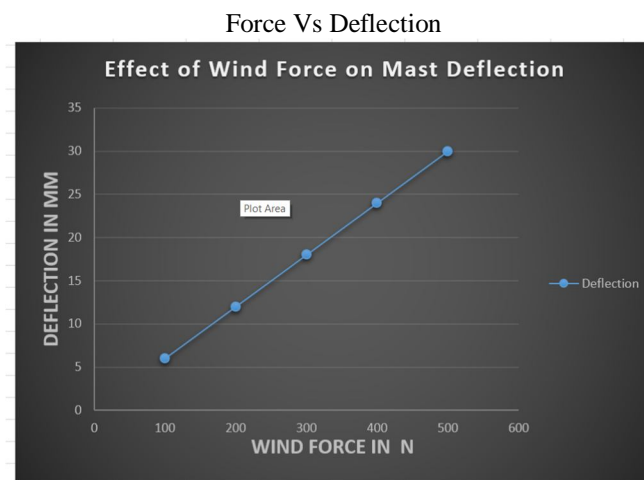

Fig. Deflection analysis of Mast

The Graph is plotted for the observations of the mast deflection against the various forces.

Sr.No.	Force (in N)	Deflection (in mm)
1.	100	6.01
2.	200	12
3.	300	18
4.	400	24
5.	500	30



From this graph, it is understood that the relationship between force and deflections is linear. It means the deflections is directly proportional to the applied force. Therotically this data is obtained and plotted on the graph with Force on X-axis and Deflection on Y-axis. As dependent variable is to be plotted on Y axis and independent variable on X axis which in our case deflection is dependent on Force applied. Practical scenario may be different as some losses will be incurred in it. But more or less the linear relationship will also be satisfied there.

The further analysis done by us was for the number of revolutions and the torque available at the dynamometer shaft. This parameters were calculated for a fixed power of 15 W. The purpose was to find a relationship between the torque and revolutions so that a therotical analysis can be done and predict a output for infinite numbers.

Therefore, the next graph we plotted is between the torque produced and the number of revolutions required for power generation of 15 W.

Sr. No.	Toque (N-m)	Revolutions(RPM)
1.	0.601	14300.1
2.	2.4	3580
3.	5.4	1591.54
4.	9.6	895.24
5.	15	572.95

Torque Vs RPM

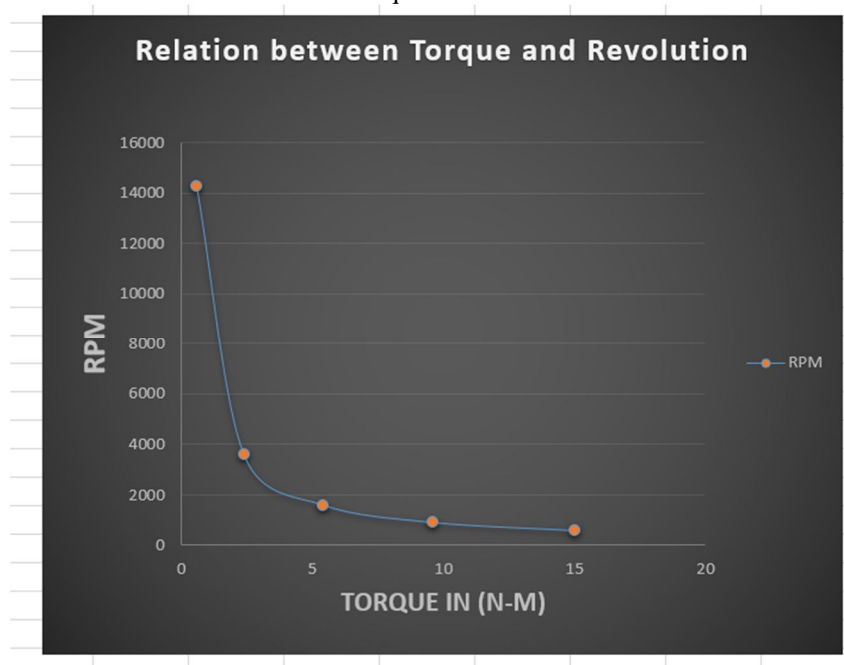

From this graph, it is seen that as the torque increases the number of revolutions decrease for the same power generation. The relationship between them is inversely proportional and decreasing parabolically.

$$N \propto 1/T$$

There is a drastic change at the minimum force and then the curve smoothens. It means larger the force more will be the torque and accordingly number revolutions of the shaft are less for the same power.

Hence, from these results it may be concluded that number of revolutions may be minimum for maximum torque produced. Therefore, the aim will be increasing torque transmitting capacity by increasing wheel size but upto a fixed value otherwise system will become bulky and increase cost.

VIII. CONCLUSION

Wind energy is the cleanest and easily available source of energy. It doesn't cost a single penny for the usage and we can make maximum of it. Our project is one of the efficient way to produce power from wind energy among different ways available already. The paper concludes that Bladeless windmill is helpful for individual, residential and a small scale industry. The cost is not so high and hence can be easily afforded by them. We are successful in eliminating the high cost, bulk space, maintenance problems associated with the conventional windmills. The bladeless windmill will surpass these problems and will give more or less power output. (Depending upon application and resources)

Wind energy is the future of power producing era and will play an incredible role for it. The world is advancing towards a vision of "Net Zero Carbon Emission". This vision will achieve only when we eliminate by replacing carbon emitting fuels with non-conventional source of energy. Our project will play a vital role in achieving this goal and will be even more efficient if modifications done in future.



REFERENCES

- [1] Design of Machine elements By V.B. Bhandari.
- [2] Design of Machine structure By Sharma & Agrawal.
- [3] https://www.youtube.com/watch?v=2_5K4kmm_sL4 Power Generation by Bladeless Windmill Abhilash Khairkar¹, Prof. Saurabh Bobde², Prof. Saurabh Bobde³, Gaurao Gohate⁴, Department of Mechanical Engineering, DBACER Nagpur
- [4] <https://www.indiegogo.com/projects/vortexbladeless-a-wind-generator-withoutblades-->
- [5] <http://ijsetr.org/wpcontent/uploads/2015/04/IJS ETR-VOL-4>
- [6] www.ijsrd.com/articles/IJSRDV4I31605.pdf
- [7] https://en.wikipedia.org/wiki/Vortex_Bladeless
- [8] Study of Vortex Induced Vibrations for Harvesting Energy by Prof. Saurabh Bobde, Gaurao Gohate, Abhilash Khairkar, Sameer Jadhav. Paper No. (IJRSR 2349-6010 Vol.2.Issue 11, April 2016)
- [9] Gaurao Gohate, Abhilash Khairkar, Sameer Jadhav (2016), "Study of Vortex Induced Vibrations for Harvesting Energy"
- [10] Prof. Harshith K, Blayan Santosh Fernandes, Shreerama P R, Thilak Raj (2016), "Bladeless Wind Power Generation"
- [11] Banafsheh Seyed-Aghazadeh, Daniel W. Carlson, Yahya Modarres-Sadeghi, T. Senior, A. Alderson (2014), "The influence of taper ratio on vortexinduced vibration of tapered cylinders in the crossflow direction"
- [12] Antonio Barrero-Gila, Santiago Pindadob, Sergio Avilac, "Extracting energy from Vortex-Induced Vibrations: A parametric study"



10.22214/IJRASET



45.98



IMPACT FACTOR:
7.129



IMPACT FACTOR:
7.429



INTERNATIONAL JOURNAL FOR RESEARCH

IN APPLIED SCIENCE & ENGINEERING TECHNOLOGY

Call : 08813907089  (24*7 Support on Whatsapp)