



# IJRASET

International Journal For Research in  
Applied Science and Engineering Technology



---

# INTERNATIONAL JOURNAL FOR RESEARCH

IN APPLIED SCIENCE & ENGINEERING TECHNOLOGY

---

**Volume: 9      Issue: VI      Month of publication: June 2021**

**DOI: <https://doi.org/10.22214/ijraset.2021.35505>**

**[www.ijraset.com](http://www.ijraset.com)**

**Call:  08813907089**

**E-mail ID: [ijraset@gmail.com](mailto:ijraset@gmail.com)**

# Reliability Evaluation of Bulk Power Systems Incorporating UPFC

Mr. B. Madhu<sup>1</sup>, Ms. G. Bhavani Deepthi<sup>2</sup>, Ms. T. Sumalatha<sup>3</sup>, Mr. MD. Shujayathullla<sup>4</sup>

Affiliated to Jawaharlal Nehru Technological University, Hyderabad, Telangana

Department of Electrical and Electronics Engineering, ACE Engineering College, Ghatkesar, Telangana

**Abstract:** Unified power flow controller (UPFC) is one of the most advanced flexible AC transmission system (FACTS) devices that can simultaneously and independently control both the real and reactive power flow in a transmission line. The utilization of UPFC can result in significant reliability benefits in modern power systems. This paper proposes a novel reliability network model for a UPFC, which incorporates the logical structure and the distinct operating modes of a UPFC. Two-state or three-state models have been used for UPFC by previous researchers. The proposed model divides the UPFC operating modes into four states, namely the UPFC up state, STATCOM state, SSSC state and UPFC down state, in order to improve the accuracy of the model by recognizing the practical operating states of a UPFC. The new model also incorporates an AC flow-based optimal load shedding approach to assess the impact of bus voltages and reactive power flow on UPFC in order to decide appropriate load curtailment in the reliability evaluation process. The performance of the proposed model is verified using a test system, and compared with different reliability models of UPFC. Various operating schemes, such as different placement locations of UPFC, and different capacities of UPFC are used to illustrate the advantages of the developed models, and to examine the impacts of UPFC on the system reliability.

**Keywords:** Unified power flow controller; reliability evaluation; bulk power system; load curtailment model

## I. INTRODUCTION

It becomes important to develop appropriate reliability models for flexible alternating current transmission system (FACTS) devices in order to carry out realistic reliability evaluation of power systems that incorporate FACTS devices. A number of studies have been conducted recently to investigate the impact of FACTS devices on the system reliability. Most researchers have focused on conventional FACTS devices, such as Static Var compensator (SVC), thyristor controlled series compensator (TCSC) and thyristor controlled phase angle regulator (TCPAR) [1-6]. There is relatively little research reported on the reliability implications of unified power flow controller (UPFC).

UPFC is currently the most versatile FACTS device available as it combines the good properties of both the static synchronous compensator (STATCOM) and the static synchronous series compensator (SSSC). UPFC is capable of providing active and reactive power control, as well as adaptive voltage magnitude control [7]. Reference [3] proposes a reliability model of TCSC based on a state-space method, and the TCSC is used to adjust the power distribution between two different parallel transmission lines. A DC flow-based nonlinear optimization model is developed to evaluate the impact of TCSC on the reliability of a power system in [4]. References [5] and [6] present analyses of the reliability effects of TCSC, SVC and TCPAR using expanded optimal power flow (OPF) method to evaluate the control capabilities of the three FACTS devices. A UPFC system is classified into three subsystems, and a three-state reliability model is developed based on the state-space method in [8]. A reliability model of UPFC, considering only the failures of the converters and the control units is proposed using a state-space method in [9], and the model is used with the Dig Silen power system analysis software for reliability evaluation of a BPS. A three-state model of a transmission component with FACTS is developed to study the impacts of UPFC on the reliability of a bulk power system (BPS) in [10]. A network flow method is used to curtail the load, and the impacts of UPFC on bus voltage and reactive power are not considered in the model.

This paper proposes a new reliability model for the UPFC that recognizes the logical structure and the four distinct operating modes of UPFC using an enumeration approach. The major advantage of the proposed model is that a four-state model is used to simulate the practical operating states of UPFC more accurately compared to the traditional two-state or three-state models. The new model also incorporates an AC flow-based optimal load shedding approach to identify bus voltage violations in addition to overload situations in order to decide the optimum load curtailment in the reliability evaluation process.

## II. RELIABILITY MODELS FOR A UPFC

Figure 1 shows a schematic diagram of a typical UPFC [1-3, 8] that has two voltage-sourced converters. The two converters are labeled as ‘Shunt converter’ and ‘Series converter’. The shunt converter is connected in shunt with the transmission line through two redundant shunt-connected transformers T11 and T12, and the series converter is connected in series with the transmission line through a series insertion transformer T2. The DC terminals of the two converters are connected together with a common DC link and four DC capacitors. IT1 and IT2 are intermediate transformers.

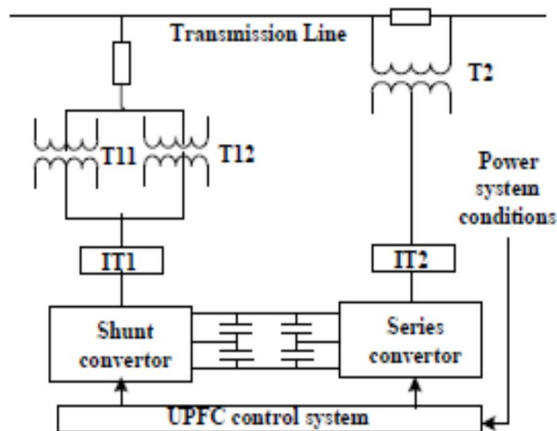

Figure 1. UPFC schematic diagram

The basic operating principle of the UPFC is as follows. The series converter provides the main function of the UPFC by injecting an AC voltage with controllable magnitude and phase angle in series with the transmission line via the series transformer T2. The basic function of the shunt converter is to supply or absorb the real power demanded by the series converter at the common DC link. In an ideal condition, the active power supplied to the shunt converter must satisfy the active power demanded by the series converter. In other words, the UPFC does not consume any active power [1-2, 7-8].

### A. Three-state reliability models for a UPFC

A key step in the reliability evaluation process for power systems incorporating UPFC is to analyze the failure modes of UPFC components and evaluate their effects on the system reliability. A three-state reliability model for the UPFC is proposed based on the three operating states of UPFC, i.e. up state, 50% derated state and down state [8]. Before presenting the four-state model, the three-state model in [8] is first extended in this paper using an enumeration method to incorporate the following reliability effects of component failures.

- 1) If only one bridge is down in a converter and the other components are up, the UPFC is in the 50% derated state. If both the bridges in a converter are down simultaneously, the UPFC is in the down state.
- 2) If IT1 or IT2 is down, the UPFC is in the down state.
- 3) If T11 and T12 are down simultaneously, the UPFC is in the down state.
- 4) If T2 is down, the UPFC is in the down state.
- 5) If one or more DC capacitors are down, the UPFC is in the down state.
- 6) If the control system is down, the UPFC is in the down state.

Figure 2 shows the reliability network diagram of a UPFC obtained from the logical relationship between the UPFC components, and the analysis of the six modes of failures listed above. The block B1 consists of two identical bridges, where both are required for the system up state, and a failure of one bridge results in a 50% derated state. The same is true for the block B2.

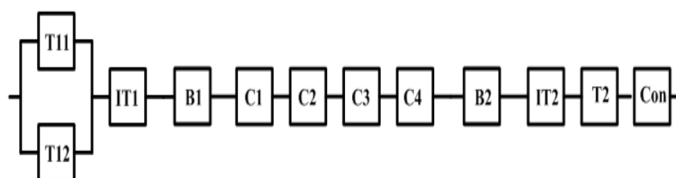

Figure 2. Reliability network diagram of the three-state UPFC model



Each of the blocks B1 and B2 in Figure 2 represents a twin converter bridges, blocks C1-C4 represent the DC capacitors, and the “Con” block represents the control system of the UPFC. The other symbols are already described in Figure 1. The reliability parameters are the same as those in [8].

Based on the three-state UPFC model and the reliability network diagram, the state probabilities and frequencies can be evaluated using basic reliability evaluation methods [11, 12]. The contingency enumeration method is used to evaluate the reliability indices in this paper [11-12]. The results for the modified three-state model are compared with the original model in [8] in Table I.

UPFC states	The proposed model		State-space model in [8]	
	Probability	Frequency (Occ./Yr)	Probability	Frequency (Occ./Yr)
Up	0.9357	4.5956	0.9358	4.58
Derated	0.0625	4.8699	0.0625	4.57
Down	0.0018	0.2021	0.0017	0.17

Table i. Reliability results of upfc using three-statemodels

It can be seen from Table I that the reliability results obtained using the proposed approach is very close to those presented in [8], and this mutually verifies the correctness of both the models. The modified three-state model, however, does not require the subsystem division and the state-space model combination as in the model in [8]. The proposed approach is more flexible, and can be extended to a four-state model described in the next section.

**B. Four-state reliability model for a UPFC**

Each converter of a UPFC can be operated independently depending on the system conditions in actual system operation. This is done by disconnecting the common DC terminals and splitting the capacitor bank. In this case, the shunt converter operates as a stand-alone STATCOM, and the series converter as a SSSC [7]. The UPFC, therefore, has three distinct operational modes: a UPFC, a STATCOM and a SSSC, which has not been considered in the traditional two-state or three state models of UPFC [8, 10]. In order to develop a realistic model by recognizing the actual operating modes of a UPFC this paper proposes a four-state reliability model based on the four operating states: UPFC up state, STATCOM state, SSSC state and UPFC down state.

The enumeration approach described in Section II-A in further extended to incorporate the four operating states by considering the reliability effects of the following modes of component failures.

- 1) The UPFC operates in the SSSC state when the shunt converter is down and the other components are up. The UPFC is, however, in the STATCOM state when the series converter is down and the other components are up. If both the converters are down simultaneously, the UPFC is in the down state.
- 2) The UPFC is in the SSSC state when IT1 is down and the other components are up. When IT2 is down and the other components are up, the UPFC is in the STATCOM state.
- 3) The UPFC is in the up state when either T11 or T12 is down, and the other components are up. When both T11 and T12 are down simultaneously and the other components are up, the UPFC is in the SSSC state. The UPFC is in the STATCOM state when T2 is down and the other components are up.
- 4) The UPFC is in the down state when one or more DC capacitors are down.
- 5) The UPFC is in the down state if the control system is down.

Figure 3 shows the modified reliability diagram of a UPFC with the four-state model obtained from the analysis of the five modes of failures listed above. The probability and frequency indices of the four UPFC states can similarly be obtained by applying the enumeration method [11-12] to the modified reliability diagram. The results using the four-state model are shown in Table II.

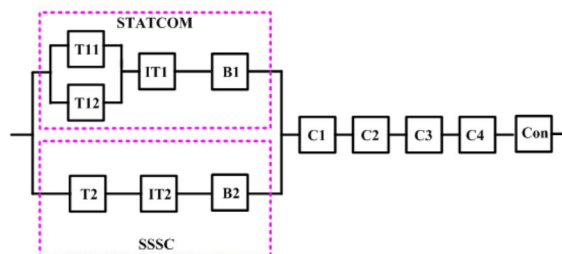

Figure 3. Reliability network diagram of a four-state UPFC model

UPFC states	Probability	Frequency (Occ./Yr)
Up	0.9357	4.5956
STATCOM	0.0313	2.3549
SSSC	0.0314	2.3564
Down	0.0016	0.2079

Table II. Reliability results of upfc using the four-state model

A comparison of the results in Table I and Table II shows that the probabilities of up state is effectively the same in the two models, in which the up state is defined in the same way. The results, therefore, mutually verify the correctness of both the models.

### III. RELIABILITY EVALUATION OF A BPS INCORPORATING UPFC

A state sampling Monte Carlo simulation method is utilized in this paper for BPS reliability evaluation. The details of this method are presented in [13-16]. The following section describes a methodology developed to embed the UPFC in the traditional OPF model to determine and implement an optimal load curtailment philosophy in the BPS reliability evaluation.

#### A. UPFC Mathematical Model

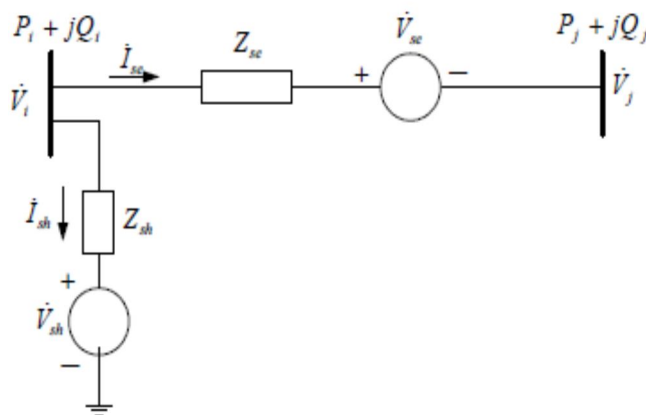

Figure 4. UPFC equivalent circuit

The equivalent circuit of a UPFC is shown in Figure 4. The shunt converter and the series converter are represented by two ideal voltage sources in series with corresponding equivalent impedances.  $V_{sh}$  and  $\theta_{sh}$  are the controllable magnitude and angle respectively of the voltage source associated with the shunt converter. Similarly,  $V_{se}$  and  $\theta_{se}$  are the magnitude and angle respectively of the voltage source associated with the series converter.  $Z_{se}$  and  $Z_{sh}$  are the equivalent impedance of the series and shunt converters respectively [1, 16].

Based on the UPFC equivalent circuit shown in Figure 4, the active and reactive power equations at bus  $i$  and bus  $j$  are [1, 2, 16]

$$\begin{aligned}
 P_i = & V_i^2 G_{ii} - V_i V_j (G_y \cos \theta_y + B_y \sin \theta_y) \\
 & - V_i V_{se} (G_y \cos(\theta_i - \theta_{se}) + B_y \sin(\theta_i - \theta_{se})) \\
 & - V_i V_{sh} (G_{sh} \cos(\theta_i - \theta_{sh}) + B_{sh} \sin(\theta_i - \theta_{sh}))
 \end{aligned} \tag{1}$$

$$\begin{aligned}
 Q_i = & -V_i^2 B_{ii} - V_i V_j (G_y \sin \theta_y - B_y \cos \theta_y) \\
 & - V_i V_{se} (G_y \sin(\theta_i - \theta_{se}) - B_y \cos(\theta_i - \theta_{se})) \\
 & - V_i V_{sh} (G_{sh} \sin(\theta_i - \theta_{sh}) - B_{sh} \cos(\theta_i - \theta_{sh}))
 \end{aligned} \tag{2}$$

$$P_j = V_j^2 G_{jj} - V_j V_j (G_{ij} \cos \theta_{ij} + B_{ij} \sin \theta_{ij}) \quad (3)$$

$$+ V_j V_{se} (G_{ij} \cos(\theta_j - \theta_{se}) + B_{ij} \sin(\theta_j - \theta_{se}))$$

$$Q_j = -V_j^2 B_{jj} - V_j V_j (G_{ij} \sin \theta_{ij} - B_{ij} \cos \theta_{ij}) \quad (4)$$

$$+ V_j V_{se} (G_{ij} \sin(\theta_j - \theta_{se}) - B_{ij} \cos(\theta_j - \theta_{se}))$$

where  $G_{ij} + jB_{ij} = 1/Z_{se}$ ;  $G_{sh} + jB_{sh} = 1/Z_{sh}$ ;  $G_{ii} = G_{ij} + G_{sh}$ ;  $B_{ii} = B_{ij} + B_{sh}$ ;

$G_{jj} = G_{ij}$ ;  $B_{jj} = B_{ij}$ ;  $\theta_{ij} = \theta_i - \theta_j$ ;  $\theta_{ji} = \theta_j - \theta_i$ ;  $\dot{V}_i = V_i \angle \theta_i$  and  $\dot{V}_j = V_j \angle \theta_j$

are the voltages at bus  $i$  and bus  $j$  respectively.

The power equations for the shunt converter are

$$P_{sh} = V_{sh}^2 G_{sh} - V_{sh} V_{sh} (G_{sh} \cos(\theta_{sh} - \theta_i) + B_{sh} \sin(\theta_{sh} - \theta_i)) \quad (5)$$

$$Q_{sh} = -V_{sh}^2 B_{sh} - V_{sh} V_{sh} (G_{sh} \sin(\theta_{sh} - \theta_i) - B_{sh} \cos(\theta_{sh} - \theta_i)) \quad (6)$$

The power equations for the series converter are

$$P_{se} = V_{se}^2 G_{ij} - V_{se} V_{se} (G_{ij} \cos(\theta_{se} - \theta_i) + B_{ij} \sin(\theta_{se} - \theta_i)) \quad (7)$$

$$+ V_{se} V_j (G_{ij} \cos(\theta_{se} - \theta_j) + B_{ij} \sin(\theta_{se} - \theta_j))$$

$$Q_{se} = -V_{se}^2 B_{ij} - V_{se} V_{se} (G_{ij} \sin(\theta_{se} - \theta_i) - B_{ij} \cos(\theta_{se} - \theta_i)) \quad (8)$$

$$+ V_{se} V_j (G_{ij} \sin(\theta_{se} - \theta_j) - B_{ij} \cos(\theta_{se} - \theta_j))$$

In an ideal situation, the active power supplied to the shunt converter must satisfy the active power demanded by the series converter, and therefore, the UPFC does not consume active power.

$$\text{Re}(\dot{V}_{sh} \dot{I}_{sh}^*) + \text{Re}(\dot{V}_{se} \dot{I}_{se}^*) = 0 \quad (9)$$

Where  $I_{se}$  is the current drawn from the series branch  $i-j$  at bus  $i$ ;  $I_{sh}$  is the current extracted from the shunt branch at bus  $i$ .

The bound constraints on the capacity of the two converters are

$$\sqrt{P_{sh}^2 + Q_{sh}^2} \leq S_{sh \max} \quad (10)$$

$$\sqrt{P_{se}^2 + Q_{se}^2} \leq S_{se \max} \quad (11)$$

where  $S_{se \max}$  and  $S_{sh \max}$  are the upper limits of the capacity of series and shunt converters respectively.

The bound constraints of the voltage magnitude and angle of the two ideal voltage sources are

$$V_{sh \min} \leq V_{sh} \leq V_{sh \max} \quad (12)$$

$$0 \leq \theta_{sh} \leq 2\pi \quad (13)$$

$$V_{se \min} \leq V_{se} \leq V_{se \max} \quad (14)$$

$$0 \leq \theta_{se} \leq 2\pi \quad (15)$$

where  $V_{se \max}$  ( $V_{se \min}$ ) and  $V_{sh \max}$  ( $V_{sh \min}$ ) are the upper (lower) limits of the voltage magnitude of series and shunt converters respectively.

**B. OPF Model for Load Curtailment Considering the Effects of UPFC**

A non-linear OPF model based on AC load flow method for optimal load curtailment in reliability evaluation of a BPS is presented in [15].

$$\text{Objective: } LC(x) = \min\left(\sum_{i=1}^n (P_{di} - P_{li})\right) \quad (16)$$

Subject to:

$$\begin{cases} P_i + P_g - P_{gi} = \sum_{j=1}^n V_i V_j (G_{ij} \cos \theta_{ij} + B_{ij} \sin \theta_{ij}) + P_{di} - P_{gi} = 0 \\ Q_i + Q_g - Q_{gi} = \sum_{j=1}^n V_i V_j (G_{ij} \sin \theta_{ij} - B_{ij} \cos \theta_{ij}) + Q_{di} - Q_{gi} = 0 \\ \forall i, j = 1, 2, \dots, n \end{cases} \quad (17)$$

$$\begin{cases} P_{gi\min} \leq P_{gi} \leq P_{gi\max} \\ Q_{gi\min} \leq Q_{gi} \leq Q_{gi\max} \\ \forall i = 1, 2, \dots, n_g \end{cases} \quad (18)$$

$$\begin{cases} 0 \leq P_{li} \leq P_{di} \\ 0 \leq Q_{li} \leq Q_{di} \\ P_{li} / Q_{li} = P_{di} / Q_{di} \\ \forall i = 1, 2, \dots, n_d \end{cases} \quad (19)$$

$$\begin{cases} |S_{ij}| = \sqrt{P_{ij}^2 + Q_{ij}^2} \leq S_{ij\max} \\ |S_{ji}| = \sqrt{P_{ji}^2 + Q_{ji}^2} \leq S_{ji\max} \\ ij \in [1, 2, \dots, n_b] \end{cases} \quad (20)$$

where  $P_i$  and  $Q_i$  are the active and reactive power respectively injected at bus  $i$ ;  $P_{gi\min}$  and  $P_{gi\max}$  are the active power limits of the generators at bus  $i$ ;  $Q_{gi\min}$  and  $Q_{gi\max}$  are the reactive power limits of the generators at bus  $i$ ;  $P_{gi}$  and  $Q_{gi}$  are the active and reactive generation outputs respectively at bus  $i$ ;  $P_{di}$  and  $Q_{di}$  are the load demands at bus  $i$ ;  $P_{li}$  and  $Q_{li}$  are the actual load supply at bus  $i$ ;  $S_{ij\max}$  is the line capacity limit of branch  $i-j$ ;  $V_{i\min}$  and  $V_{i\max}$  are the voltage magnitude limits of bus  $i$ ;  $n$ ,  $n_g$ ,  $n_d$  and  $n_b$  are the numbers of buses, generator buses, load buses and branches respectively.

Any change in power injection at bus  $i$  and  $j$  of Figure 4 is calculated from Equation (17), in which, the impact of UPFC on power injection at bus  $i$  is obtained from Equations (1-2), and at bus  $j$  is obtained from Equations (3-4) considering the constraints given in Equations (9-15). An OPF model that incorporates the SSSC mode or STACOM mode for load curtailment can similarly be done. Additional details on OPF models for different FACTS devices are discussed in [1].

**IV. CASE STUDIES**

A test system developed at the University of Saskatchewan designated as the RBTS [17] was used to illustrate the application of the proposed models. The RBTS has 11 generating units and a peak load of 185 MW. The generating unit and line reliability parameters are presented in [17].

The UPFC component reliability parameters provided in Reference [8] are used in this study. It is assumed that a UPFC has two 30MVA converters, and their equivalent impedances are  $Z_{se}=Z_{sh}=j0.1\text{p.u.}$ . The limits of magnitude  $V_{sh}$  and angle  $\theta_{sh}$  of the shunt voltage source are  $0.9 \leq V_{sh} \leq 1.1\text{p.u.}$  and  $0 \leq \theta_{sh} \leq 2\pi$  respectively [16]. The limits of the magnitude  $V_{se}$  and angle  $\theta_{se}$  of the series voltage source are  $0 \leq V_{se} \leq 0.5\text{p.u.}$  and  $0 \leq \theta_{se} \leq 2\pi$  respectively [16].

A computer program coded in C++ and MATLAB has been developed to incorporate the proposed model. In order to show the impact of UPFC on the system reliability, the reduction in  $EENS$  due to the application of UPFC is expressed as a percentage of the original  $EENS$  before the UPFC is incorporated in the power system

$$EENS\% = \frac{EENS_{\text{original}} - EENS_{\text{upfc}}}{EENS_{\text{original}}} \times 100 \quad (22)$$

TABLE III ANNUALIZED SYSTEM INDICES OF THE RBTS INCORPORATING A UPFC AT DIFFERENT LOCATIONS

Line No.	Different UPFC locations			Three-state model				Four-state model			
	From bus	To bus	Near bus	LOLP	LOLF (Occ./Yr)	EENS (MWh/Yr)	EENS%	LOLP	LOLF (Occ./Yr)	EENS (MWh/Yr)	EENS%
L4	3	4	3	0.01014	5.8095	1256.9	29.40	0.00999	5.5513	1248.8	29.86
L4	3	4	4	0.01301	8.5164	1380.8	22.44	0.01265	8.1187	1346.5	24.37
L5	3	5	3	0.01392	9.5586	1360.2	23.60	0.01363	9.2599	1310.0	26.41
L5	3	5	5	0.01377	9.4870	1311.5	26.33	0.01356	9.1453	1277.6	28.24
L8	4	5	4	0.01294	8.3771	1384.3	22.24	0.01257	7.9837	1350.0	24.17
L8	4	5	5	0.01016	5.9741	1277.4	28.25	0.01002	5.6685	1253.1	29.61
L9	5	6	5	0.01276	8.2831	1315.1	26.13	0.01242	7.8591	1275.6	28.35
L9	5	6	6	0.01269	8.2624	1320.6	25.82	0.01247	7.8991	1299.3	27.02
No UPFC				0.01654	12.2310	1780.3	-	-	-	-	-

where  $EENS_{original}$  and  $EENS_{upfc}$  are the system *EENS* indices without and with considering the UPFC respectively. The *EENS%* index obviously quantifies the degree of the impact of the UPFC on the system reliability. Because the UPFC is used to increase the use-capacity of existing transmission system, the peak load conditions and annualized reliability indices are used in this paper to examine

A. Basic Analysis

It can be seen from Table III that the reliability performance of the RBTS is improved when a UPFC is installed to a transmission line. This is due to the fact that the UPFC simultaneously and independently controls the active and reactive power flow in transmission lines, and controls the bus voltages. In this case, some abnormal states in the original RBTS system are converted to the normal states or states with reduced load curtailment. Table III also shows that the installed locations of the UPFC have a significant impact on the system reliability. Installation of the UPFC on branch L4 close to bus 3 of the RBTS provides the greatest improvement in the overall system reliability. The determination of the optimal UPFC location in a large power system is a very complex problem. The detailed discussion on this problem is beyond the scope of the paper.

B. Comparison Between The Three-State And Four-State Models

The four-state model represents the actual operating modes of a UPFC more closely than a three-state model, and therefore, provides more accurate results. Table III shows that the threestate model provides a more pessimistic reliability assessment than a four-state model. A sensitivity study was conducted for the two models using different failure rates for the UPFC converters. The impacts of converter failure rate on the system EENS are shown in Figure 5.

It can be seen from Figure 5 that the reduction in the system EENS increases with the converter failure rate when the UPFC is represented by the four-state model instead of the three-state model. This is due to the fact that the three-state model does not consider the STATCOM or SSSC state of a UPFC, and this model regards these two states as failure states in the reliability evaluation process. The control and adjustment of UPFC to alleviate or minimize the extent of system outage during these states are not recognized in the three-state model. The threestate model therefore usually provides an underestimation of the reliability performance, whereas the four-state model provides a more accurate technique for evaluating the impact of UPFC on the system reliability.

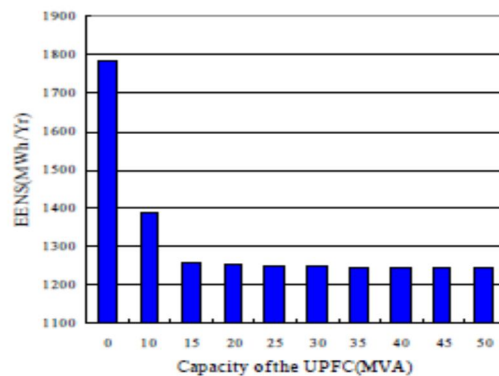



**C. Impacts of the capacity of UPFC on the system reliability**

Figure 6 shows the impact of the UPFC capacity on the annualized EENS index when the UPFC is installed on branch L4 close to bus 3. It can be seen from Figure 6 that the system EENS decreases, or the system reliability increases with an increase in the UPFC capacity, but tends to saturate when the UPFC capacity exceeds 30MVA. When the saturation occurs, other measures should be considered to improve the system reliability since an increase in UPFC capacity will not significantly contribute to improving system reliability.

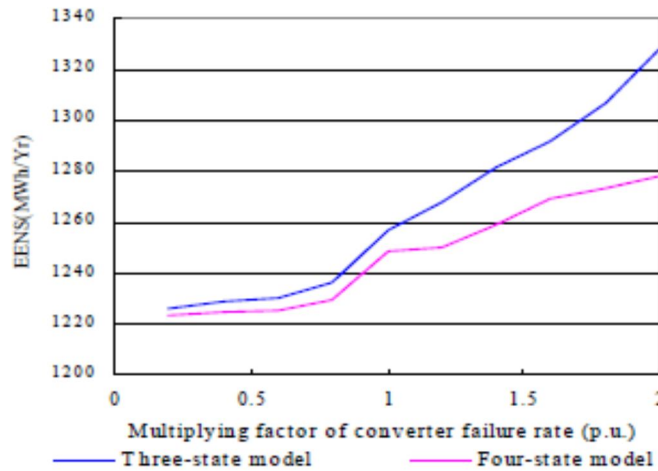

Figure 6. Impacts of converter failure rate on the EENS index

**V. CONCLUSION**

This paper proposes a new four-state reliability model for a UPFC. A methodology that incorporates the UPFC model in an AC flow-based optimal load shedding approach to identify optimum load curtailment in the reliability evaluation process is presented. Comparisons of the impacts of the UPFC on the system reliability using different models show that the precision of the proposed model is relatively higher than the traditional models.

**REFERENCES**

- [1] X. Zhang, C. Rehtanz and B. Pal, Flexible AC Transmission Systems: Modeling and Control. Berlin: Springer, 2006.
- [2] J. F. Keri, X. Lombard, A. A. Edris, A. S. Mehraban and A. Elriachy, "Unified Power Flow Controller(UPFC): Modeling and Analysis," IEEE Trans. Power Deliv., vol. 14, no. 2, pp. 648-654, Apr. 1999.
- [3] R. Billinton, M. Fotuhi-firuzabad and S. O. Faried, "Power System Reliability Enhancement using a Thyristor Controlled Series Capacitor," IEEE Trans. Power Syst., vol. 14, no. 1, pp. 369-374, Feb. 1999.
- [4] K. Verma, A. Srividya and B. C. Deka, "Impact of a FACTS controller on reliability of composite power generation and transmission system," Electric Power Systems Research, vol. 72, no. 2, pp. 125-130, Dec. 2004.
- [5] G. M. Huang and Y. Li, "Impact of Thyristor Controlled Series Capacitor on Bulk Power System Reliability," in proc. IEEE Power Engineering Society Summer Meeting, Chicago, America, Jul. 2002, pp. 975-980.
- [6] G. M. Huang and Y. Li, "Composite power system reliability evaluation for systems with SVC and TCPAR," in proc. IEEE Power Engineering Society General Meeting, Toronto, Canada, Jul. 2003, pp. 771-776.
- [7] C. D. Schauder, D. M. Hamai, L. Gyugyi, T. R. Rietman, A. Edris, M.
- [8] R. Lund and D. R. Torgerson, "Operation of the unified power flow controller (UPFC) under practical constraints," IEEE Trans. Power Deliv., vol. 13, no. 2, pp. 630-639, Apr. 1998.
- [9] F. Aminifar, M. Fotuhi-Firuzabad and R. Billinton, "Extended reliability model of a unified power flow controller," IET Proc-Gener. Transm. Distrib., vol. 1, no. 6, pp. 896-903, Nov. 2007.
- [10] Rajabi-Ghahnavieh, M. Fotuhi-Firuzabad and R. Feuillet, "Evaluation of UPFC impacts on power system reliability," in proc. IEEE/PES Transmission and Distribution Conference and Exposition, Chicago, America, Apr. 2008, pp. 1-8.
- [11] R. Billinton and Y. Cui, "Reliability evaluation of composite electric power systems incorporating FACTS," in proc. IEEE Canadian Conference on Electrical Computer Engineering, Winnipeg, Canada, May 2002, pp. 1-6.
- [12] R. Billinton and D. S. Ahluwalia, "Incorporation of a DC link in a composite system adequacy assessment — DC system modelling," IEE Proc-Gener. Transm. Distrib., vol. 139, no. 3, pp. 221-225, May 1992.
- [13] R. Billinton, S. Aboreshaid and M. Fotuhi-Firuzabad, "Well-being analysis for HVDC transmission system," IEEE Trans. Power Syst., vol. 12, no. 2, pp. 913-918, May 1997.
- [14] R. Billinton and R. N. Allan, Reliability of Electric Power System. New York and London: Plenum, 1996.
- [15] R. Billinton and W. Li, Reliability Assessment of Electric Power Systems Using Monte Carlo Methods. New York: Plenum, 1994.
- [16] W. Li, Risk Assessment of Power Systems: Models, Methods and Applications. Piscataway, NJ: IEEE Press, 2005.

[17] C. R. Fuerte-Esquivel and E. Acha, "Unified power flow controller: a critical comparison of Newton - Raphson UPFC algorithms in power flow studies," IEE Proc-Gener. Transm. Distrib., vol. 144, no. 5, pp. 437- 444, Sept. 1997.



[18] R. Billinton, S. Kumar, N. chowdhury, K. Chu, K. Debnath, L. Goel, E. Khan, P. Kos, G. Nourbakhsh and J. Oteng-Adjei, "A reliability test system for education purposes-basic data," IEEE Trans. Power Syst., vol. 4, no. 3, pp. 1238-1244, Aug. 1989.

### BIOGRAPHIES

Mr B Madhu

Assistant Professor EEE Department ,ACE Engineering College india, he received B.Tech from VJIT Hyderabad, M.Tech Electrical Power Systems from JBIET Hyderabad in 2012.currently pursuing Ph.D from JNTU

Hyderabad.his areas of interest are Power Systems Reliability and Power Quality.



Ms. G. Bhavani Deepthi

Student of EEE department. She was born in the year 1999. She did her intermediate from SR junior college, Boduppal & pursuing B.Tech from ACE Engineering college. Actively participate in several national hackathons. Her area of interest are control systems, power quality and power electronics.



Ms. T. Sumalatha

Student of EEE department. She was born in the year 1999. She did her Diploma in Government Polytechnic College, Nalgonda & pursuing B.Tech from ACE Engineering college. Actively participate in several national hackathons. Her area of interest are Machines, power quality and power electronics.



Mr. MD. Shujayathulla

Student of EEE department. He was born in the year 1997. He did his Diploma from TTR college of Engineering, Patancheru & pursuing B.Tech from ACE Engineering college. Actively participate in several national hackathons. His area of interest in power electronics.



10.22214/IJRASET



45.98



IMPACT FACTOR:  
7.129



IMPACT FACTOR:  
7.429



# INTERNATIONAL JOURNAL FOR RESEARCH

IN APPLIED SCIENCE & ENGINEERING TECHNOLOGY

Call : 08813907089  (24\*7 Support on Whatsapp)