



# **iJRASET**

International Journal For Research in  
Applied Science and Engineering Technology



---

# **INTERNATIONAL JOURNAL FOR RESEARCH**

IN APPLIED SCIENCE & ENGINEERING TECHNOLOGY

---

**Volume: 9      Issue: VI      Month of publication: June 2021**

**DOI: <https://doi.org/10.22214/ijraset.2021.35538>**

**[www.ijraset.com](http://www.ijraset.com)**

**Call:  08813907089**

**E-mail ID: [ijraset@gmail.com](mailto:ijraset@gmail.com)**

# Simulation of Fuzzy Logic Controller Interfaced, Utility Grid Integrated Solar Water Pumping System using PMSM Drive

Chenna Nikhil<sup>1</sup>, Suroju Sandeep<sup>2</sup>, Mothe Saikrishna Reddy<sup>3</sup>, Dr. P. Ravibabu<sup>4</sup>

<sup>1, 2, 3</sup>UG Student, <sup>4</sup>Professor of Dept. Of EEE, Sreenidhi Institute Of Science and Technology Hyderabad, INDIA.

**Abstract:** *In this paper we are integrating utility grid to the DC link of solar water pumping system to eliminate intermittent nature of a solar energy and interfacing fuzzy logic controller to eliminate non-linearity of the system, controlling speed of a motor to a precise level, smoothen the operation of motor without ripples in supply to PMSM (Permanent Magnet Synchronous Motor).*

**Keywords:** *Utility grid integration, FOC scheme with MRAS control, fuzzy logic controller.*

## I. INTRODUCTION

The rising energy concerns have motivated the researchers to look for alternate electrical energy solutions to slowly decrease the use of conventional energy sources. The renewable energy sources can be used alternative to conventional energy sources. We have to use the energy sources sustainably.

Solar water pumping system is one of the renewable energy sources and can decrease in the emission of greenhouse gases and carbon foot print. According to Paris climate agreement within United Nations Framework On Climate Change to reduce global emissions in effort to limit global temperature to 1.5degree C and INDIA signed it in 2016. As per UN 17 sustainable development goals "Blueprint to achieve a better and more sustainable future for all", 13<sup>th</sup> goal is on CLIMATE ACTION. We need to act to promote use of renewable energy.

Solar powered water pumping system for agricultural purpose is the operating of pump motors in agriculture is powered by solar panel. When the solar light falls on a solar panel, it will generate the DC voltage and current and this DC voltage is boosted by as per required to motor. DC voltage is converted to AC supply by voltage source inverter and this ac supply given to PMSM.

### A. Importance Of Solar Water Pumping System

The solar powered pumping system uses sunlight which does not cost at all. And by usage of solar energy we can promote the use of renewable energy which can decrease the carbon emissions leads to safe environment and the fossil fuel like coal, diesel cannot be exhausted for future generations. We the ones have to save our environment, ecosystem by reducing the non renewable methods of power generation.

And the Government of India, is promoting the use of solar energy world wide through International Solar Alliance(ISA). The Union Ministry of New and Renewable Energy (MNRE) has put calls for initiative to the One Sun, One World, One Grid (OSOWOG) initiative. The vision is 'The Sun Never Sets' and is a constant at some geographical location, globally, at any given point of time.

### B. Solar Pump Yojana 2020

Pradhan Mantri Kisan Urja Suraksha evam Utthan Mahabhiyan (PM-KUSUM) has already started in many states which aims to provide agricultural solar pumps with 90% subsidy.

### C. Drawbacks of Existed System

- 1) Intermittent nature of a solar energy.
- 2) Existed system uses a battery to store electrical energy and supply this energy whenever required to motor. But use of the battery the system complexity increases, battery maintenance needed, increase the cost and space required.
- 3) Also motor faces Intermittent of supply which leads to poor performance of the motor and less life.
- 4) The previous system not able to utilize the maximum energy from PV array.

## II. PROPOSED SYSTEM.

- 1) The Intermittent nature of solar energy from PV array is resolved by integration of Utility Grid to DC Link of solar water pumping system as grid is a source of energy which will improve the system reliability and enhances system utilization
- 2) The main reason for use of grid integration to reduce maintenance, space and cost on battery. And the another reason is the Telangana government providing the free electricity to farmers and GOI also giving incentives.
- 3) The PFC(power flow control) is used to facilitate the grid supply to DC Link as per required to motor.
- 4) MPPT(maximum power point track) to obtain maximum utilization of energy source from PV array through incremental conductance algorithm.
- 5) PMSM operated using sensor-less FOC(field oriented control) using MRAS(model reference adaptive system) aimed to control rotor speed and flux.
- 6) For the non-linear gains are required, which are provided by FUZZY LOGIC CONTROLLER.

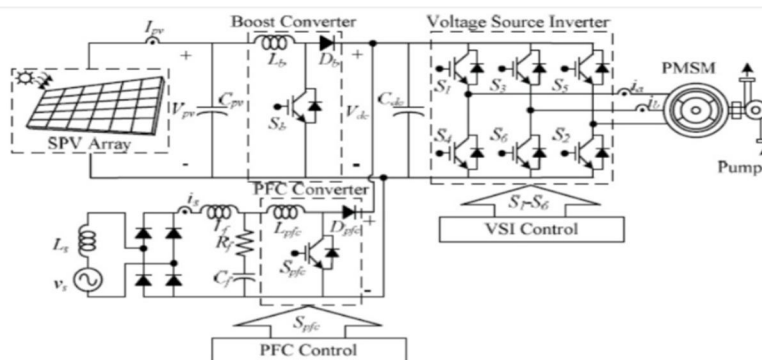

Fig 1.1 Circuit diagram of proposed system.

## III. IMPLEMENTATION OF PROPOSED SYSTEM.

So let us discuss operation and the proposed system techniques in operation. Firstly the Solar energy received by the solar panels which will convert into DC voltage and current. These DC supply needs to be amplified and inverted to feed the PMSM. The amplification of DC supply(25-41v) to the required(350v DC) to inversion(230v AC in each phase). There are two methods to amplification first one is use of Line frequency transformer by selecting proper turns ratio but due to bulkiness and high leakage inductance discourage its choice of selection. Second one is Two stage cascaded approach by dc-dc boost converter, first stage is boost of PV panel voltage to DC level by dc-dc boost converter and inversion to pure sine voltage which fed to motor by voltage source inverter stage. Two stage cascaded approach preferred here because of advantages are reduces size, power density of system is high.

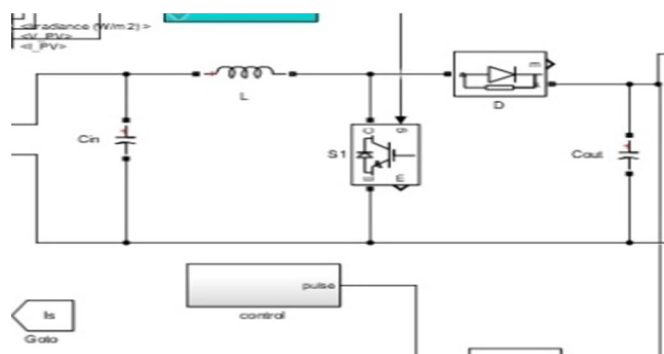

Fig 1.2 DC-DC booster.

As dc-dc boost converter shown above when switch open capacitor charged to  $V_c$  and when switch is closed here inductor charged to  $V_L$  and when switch opens it will oppose sudden change in current. so, inductor has high voltage and reverses polarity and now the total voltage is  $V_L + V_c$ , in this way DC of PV array amplified.

$V_c$ =voltage across capacitor.

$V_L$ =voltage across inductor.

A. MPPT Using INC(Incremental Conductance Method).

Now we will discuss about the MPPT(maximum power point track). MPPT is an electronic system which operates PV to achieve the maximum utilization of solar energy from PV array. MPPT is not a mechanical tracking. Maximum Power Point (MPP) does not lie at a particular point but it moves around P-V curve depends on light intensity and temperature. The widely known MPPT algorithm is P&O(perturbation& observation) and the flowchart of this algorithm can be seen is by comparing recent PV power (Pn) with the previous photovoltaic power (Pn-1). Photovoltaic power is calculated by measuring current (I) and voltage (V). When the difference between previous power and recent power is not 0, this algorithm will try to find the optimal point in the left or right side of recent position. The maximum power is attained when ΔP is equal to 0. If the recent power is higher than the previous, the duty cycle will be increased until the MPP is found. Incremental Conductance method uses the information of source voltage and current to find the required operating point.

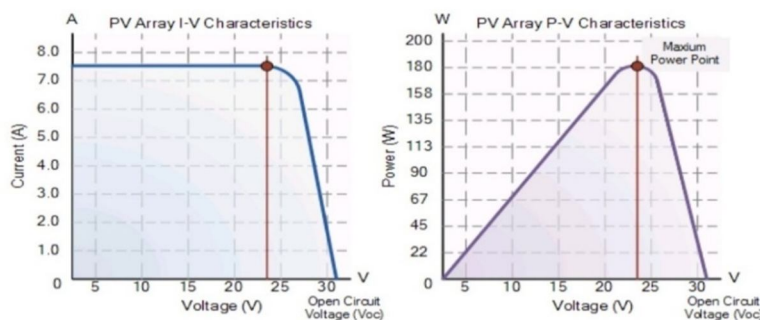

Fig 1.3 Characteristics of PV array.

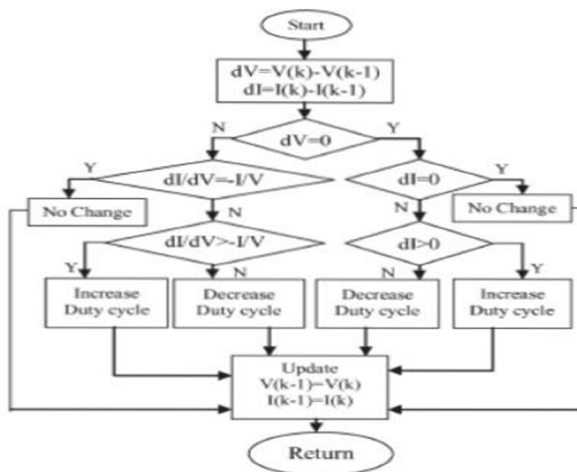

Fig 1.4 Incremental conductance algorithm for MPPT.

V(k)= Voltage of PVA(Photo voltaic array).

I(k) = Current of PVA.

V(k-1)= Past voltage value of PVA.

I(k-1)= Past current value of PVA.

Duty cycle= Ton/(Ton+Toff). For switch sb in Fig 1.1.

$$\frac{dI}{dV} = -\frac{I}{V} \quad \text{at MPP}$$

$$\frac{dI}{dV} > -\frac{I}{V} \quad \text{left of MPP}$$

$$\frac{dI}{dV} < -\frac{I}{V} \quad \text{right of MPP}$$

$$\frac{dP}{dV} = 0$$

Equation (8) can be rewritten as follows:

$$\frac{dP}{dV} = I \frac{dV}{dV} + V \cdot \frac{dI}{dV}$$

$$\frac{dP}{dV} = I + V \cdot \frac{dI}{dV}$$

And hence

$$I + V \cdot \frac{dI}{dV} = 0$$

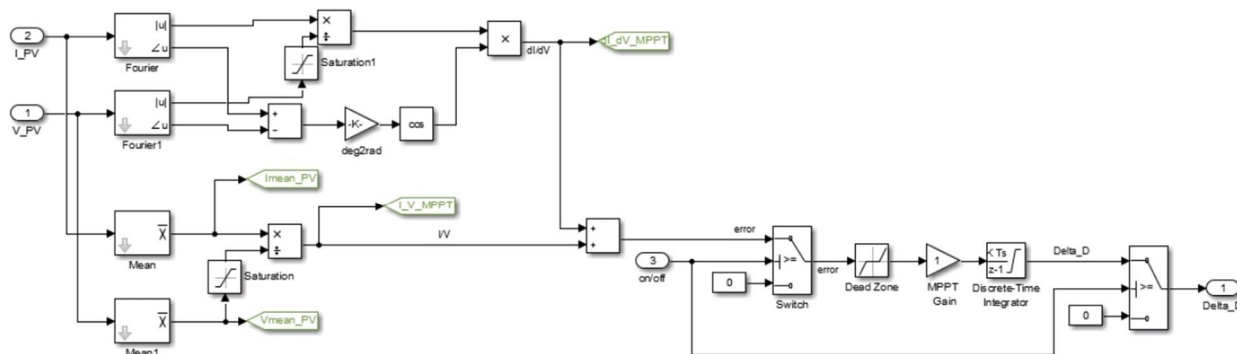

Fig 1.5 Modelling of incremental conductance MPPT method.

B. Power flow converter control (PFC).

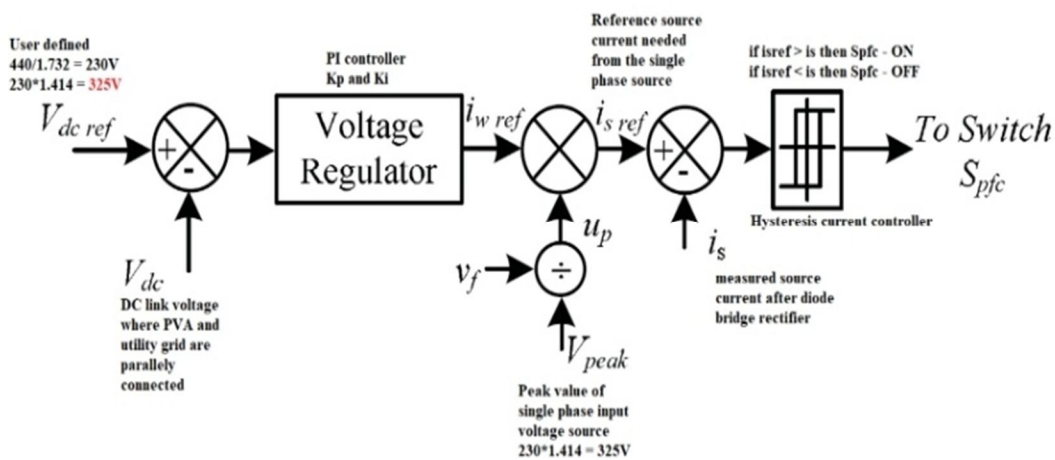

Fig 1.6 Block diagram of power flow converter control.

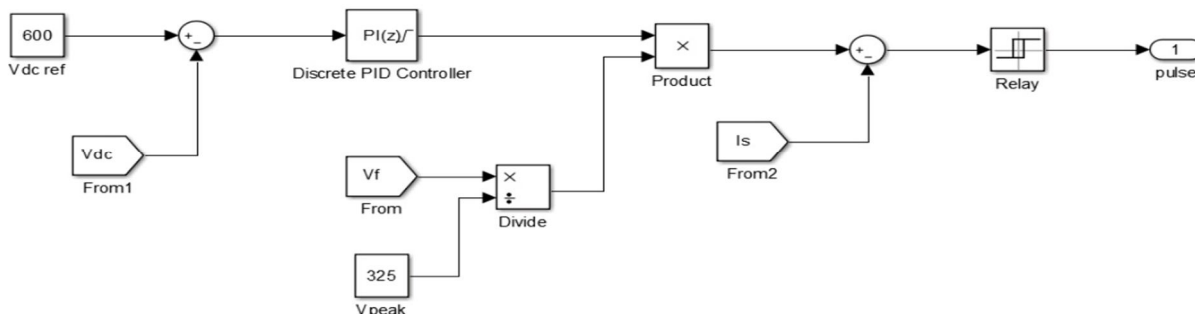

Fig 1.7 Modelling of power flow converter control.

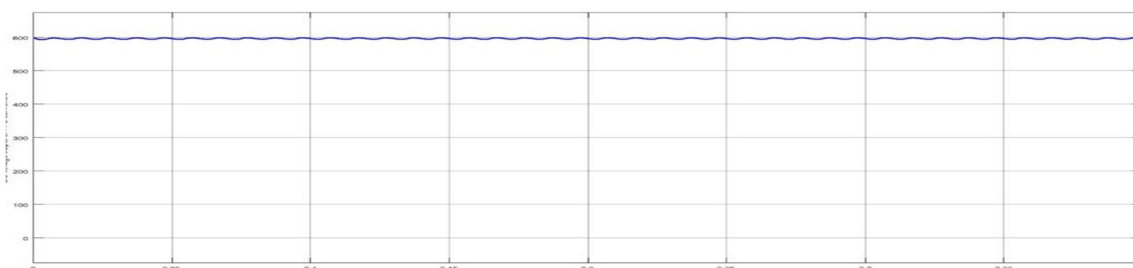

Fig 1.8 The DC maintaining constant at DC Link through PFC.

Now we will discuss about power flow control from single phase supply to DC Link as required at DC Link due to Intermittent nature of a solar energy. The single phase ac voltage is rectified by bridge rectifier and this DC passes through the RC filter to remove the harmonics and also passes through inductor which removes the ripples in DC supply and this pure DC fed to DC Link. The amount of requirement of grid supply is supplied through PFC to meet required level of DC for inversion. The PFC compares the values of Vdc and Vdc reference. Then error generates and will be given to hysteresis controller which will generates the signals which fed to the switch spfc as shown in Fig 1.1in this way the required DC voltage is maintained.

In the above controller the reference DC voltage taken is 600V which is maximum value of 440Vrms line to line voltage. The 600V is given as input to the sensor less FOC(field oriented control scheme) of PMSM drive for water pumping operation. The below is the modelling of water pumping system with PMSM drive using sensor less FOC.

**C. FOC Scheme with MRAS Control.**

FOC=field oriented control scheme.

MRAS=Model reference adaptive system.

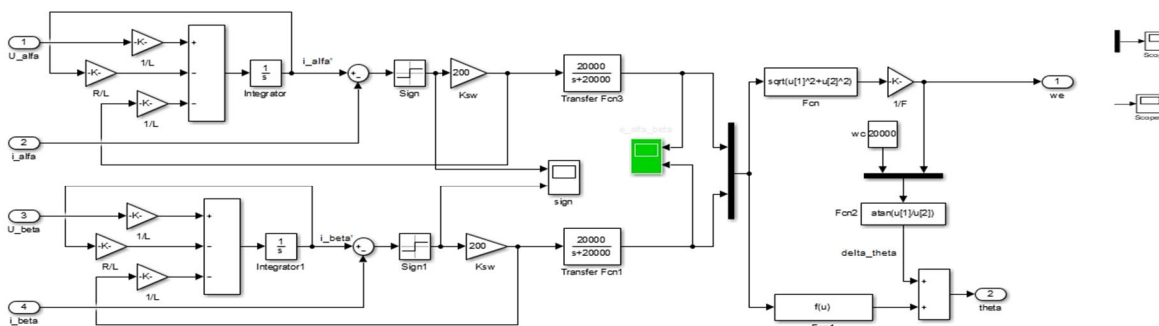

Fig 1.9 FOC scheme with MRAS control for speed control of PMSM.

Fig 2.0 MRAS control for estimation of speed and theta.

The PMSM is operated using sensor less field oriented control with speed estimator. The FOC scheme takes voltage and current feedback from the motor generating estimated speed of the machine using MRAS(model reference adaptive system) controller. The MRAS Operates by the three phase voltages given to sliding mode observer and The **Sliding Mode Observer** block computes the electrical position and mechanical speed of a PMSM by using the per unit voltage and current values and this computations given to hysteresis current controller which will generates the signals gives to switches of VSI to control speed of PMSM.

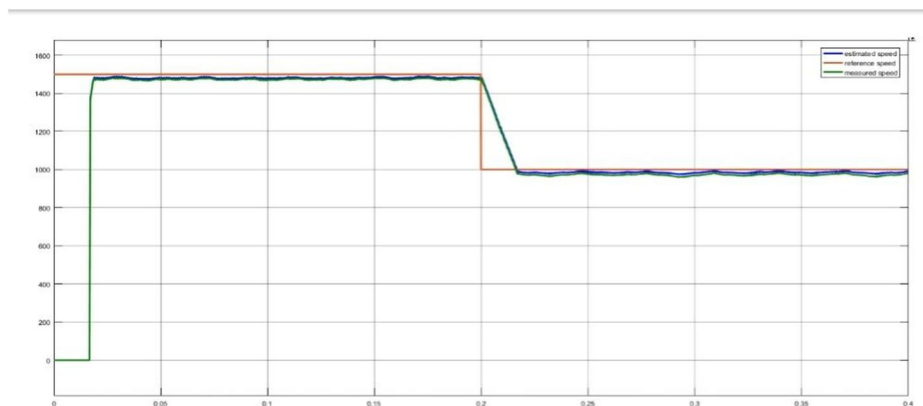

Fig 2.1 Speed of the machine compared with reference value.

#### D. Fuzzy Logic Controller

For controlling of speed of a motor to a precise level, we need to take feedback from the motor as a stator voltages(sine) and compared with the reference value and generates a error signal which will be given to controller, which will generates control excitation voltage to motor, so, speed will be maintained constant precisely. The previous system has PI regulator, which has compensator, two constants perfectly the gain constant and time constant. But in PI regulator dynamic performance satisfies but non-linearity is concerned. We have to linearize over the operating range, if not, you cannot tune controller properly. For this non-linear gains are required, which are provided by FUZZY LOGIC CONTROLLER. This will eliminate non-linearity. Smoothens the operation of motor, life and efficiency is increased to some extent.

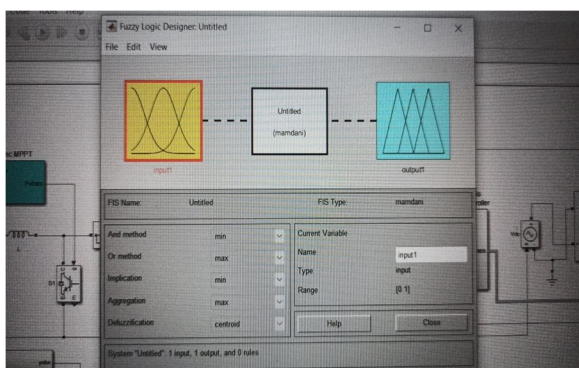

Fig 2.2 Fuzzy logic designer.

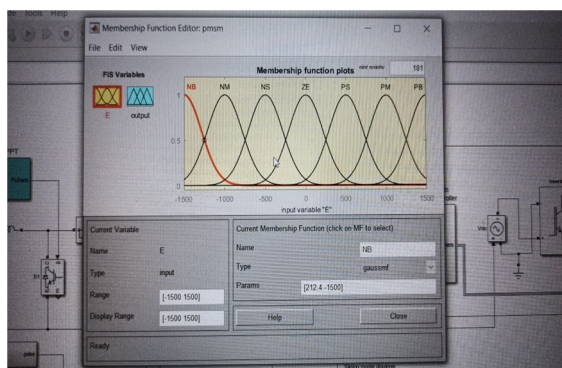

Fig 2.3 Membership function editor.

- 1) In order to implement this firstly we have to create a .fis file.
- 2) In command prompt window type FUZZY, it will display fuzzy logic designer.
- 3) Then name input and output as per your choice we named E and output respectively.
- 4) Next double click on input, it will displays MEMBERSHIP FUNCTION EDITOR to assign membership functions over speed ranges.
- 5) Select each membership function of displayed sine wave assign name and speed range for input and for output assign voltage range and name. The sequence is from low to high for speed range and voltage range.

We to apply rules through click EDIT on MEMBERSHIP FUNCTION EDITOR and select RULES.

- a) Now apply rules for membership functions as
- b) For LOW SPEED-HIGH VOLTAGE.
- c) For MEDIUM SPEED-NO CHANGE.
- d) For HIGH SPEED-LOW VOLTAGE
- e) So, according to change in speed the voltage will adjust.

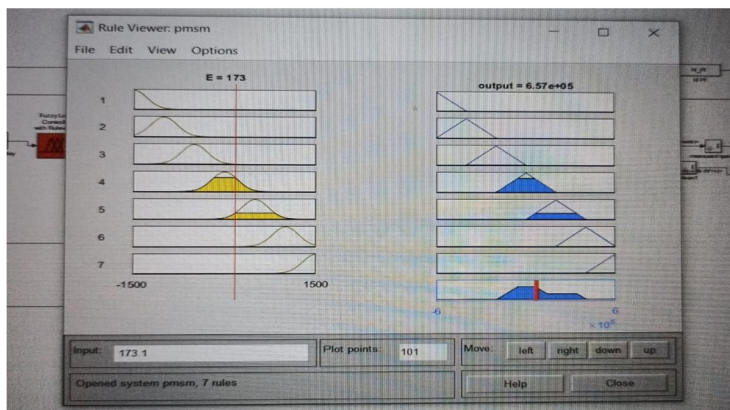
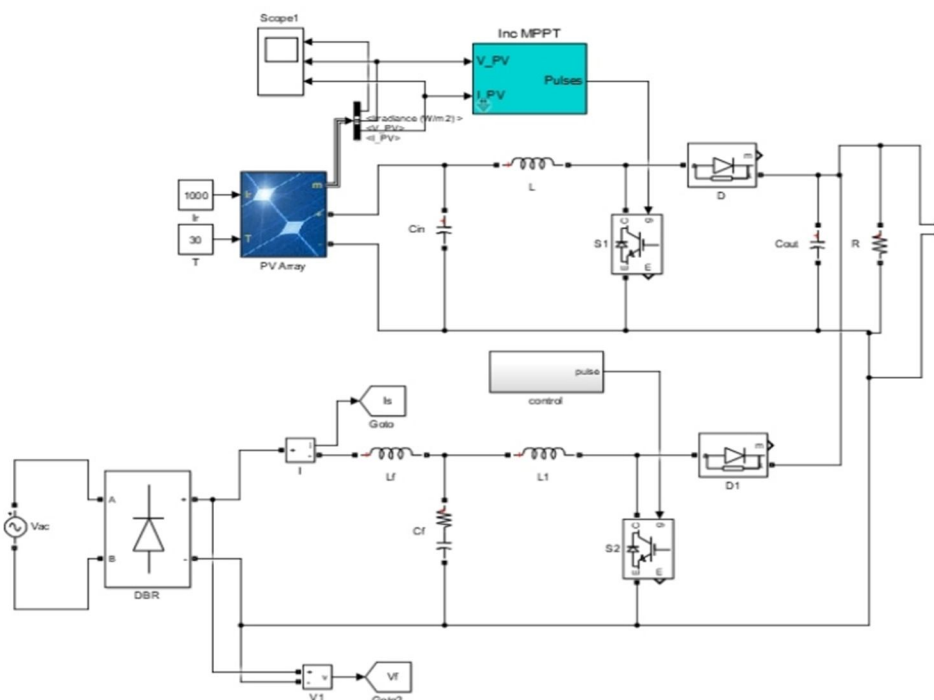

Fig 2.4 Rule viewer.

*E. Procedure To Obtain Results*

- 1) Run PI simulation file.
- 2) Open fuzzy command window. Displays fuzzy tool.
- 3) File→import from file.
- 4) Select PMSM. FIS file.
- 5) File→ export to workspace.
- 6) Run fuzzy simulation file.
- 7) Open scope 7.





#### IV. SIMULINK MODEL

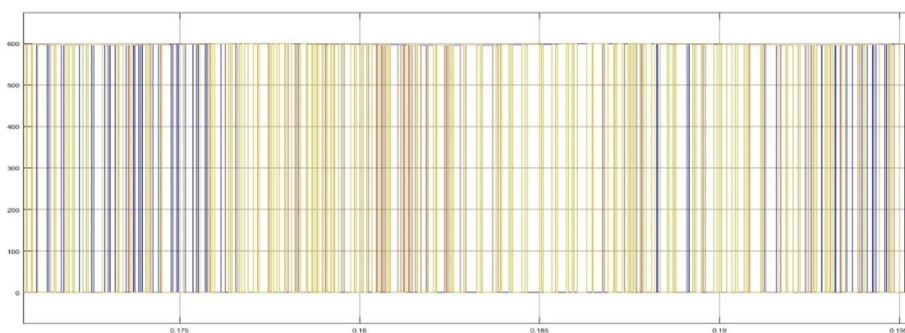
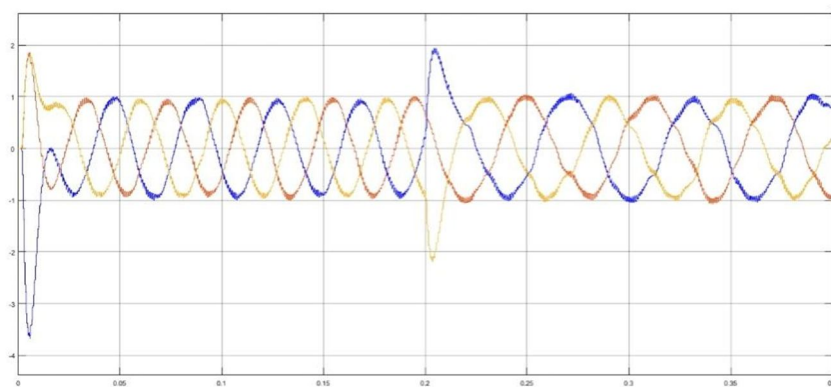

Fig 2.5 Simulink of proposed test system with PVA connected to grid.

Fig 2.6 Voltages and currents of PMSM respectively.

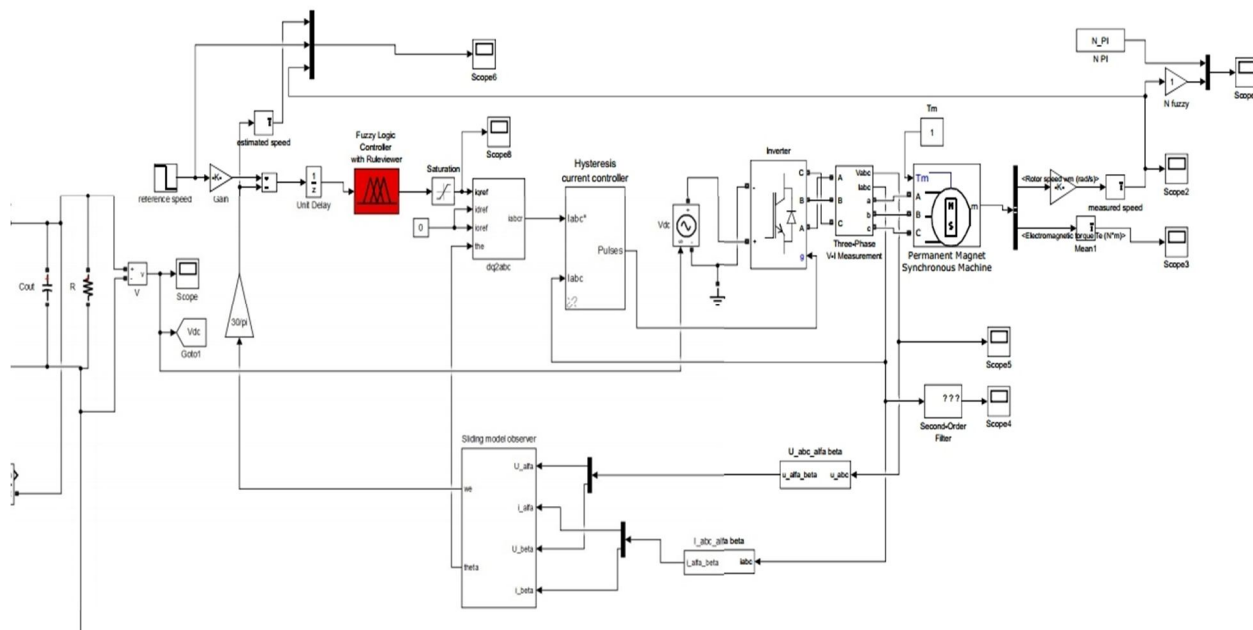

Fig 2.7 Simulink of Fuzzy logic controller.

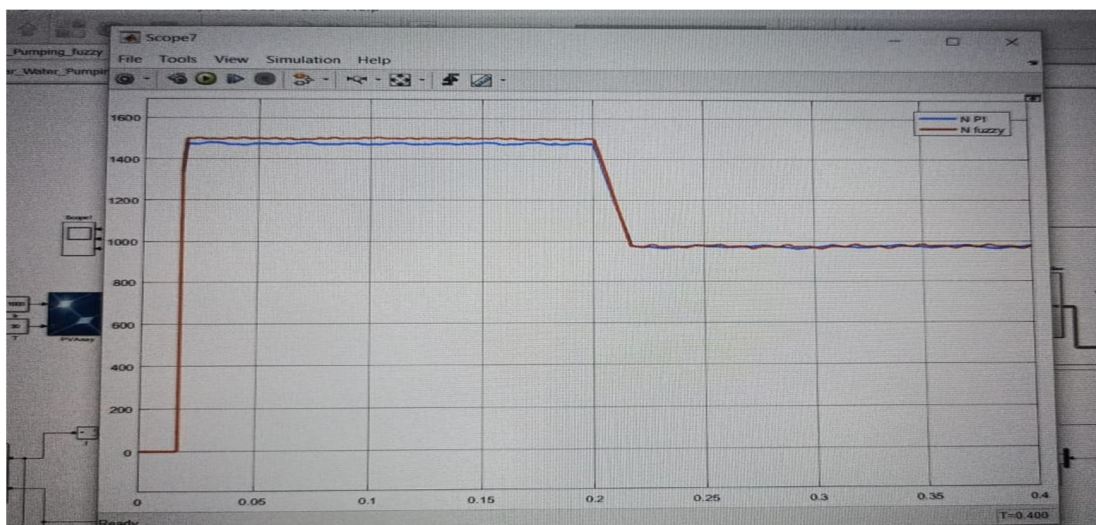

Fig 2.8 Output of Fuzzy logic controller(red line) comparing with PI controller(blue line).

The blue line and red line in picture of output indicates PI controller characteristics and Fuzzy Logic controller respectively. The characteristics shows that with fuzzy logic controller the motor operates smoothly, avoids oscillations.

#### V. ADVANTAGES

- A. Reduce dependency on fossil fuel.
- B. Reduce emissions of greenhouse gases.
- C. Reduce carbon foot print.
- D. Zero operating cost.
- E. Installation cost 90% given by GOI.
- F. Maintenance free, clean source of energy, abundant resource of nature.
- G. Resolves Intermittent nature of a solar energy.
- H. Reduce oscillations and improves the life of machine.
- I. Non-linearity eliminated.
- J. Life and efficiency of motor increases.
- K. Eliminates ripples in output supply.
- L.

#### VI. DISADVANTAGES

Conversion efficiency is still lower 44% by using amorphous silicon based cells.

#### VII. CONCLUSION

By the use of conventional energy sources the greenhouse emissions and carbon foot print increases, further global warming, this leads to increase in global temperature which will harm to mankind, living organisms in world like pandemics(novel Corona virus). In order to live living organisms, mankind have to use energy sources sustainably like use of renewable energy resources for electricity like solar water pump, electric cars which will reduce carbon emissions and coming to solar water pumping system we have integrated utility grid to DC Link which will avoid intermittent nature of solar energy, MPPT for maximum utilization of solar energy from PV panels and use of FOC with MRAS control increase the efficiency of system and finally fuzzy logic controller eliminate non-linearity of the system and eliminate ripples in output, so, life of motor increases and smooth operation of motor.

#### VIII. FUTURE SCOPE

- A. The conversion efficiency have to be increased, if conversion efficiency is increases to higher level whatever the consumption of electric energy from renewable source increases.
- B. The excess availability of electricity from panels after consumption to agricultural purpose, it can be supplied to utility grid.



#### IX. ACKNOWLEDGEMENT

We would like to place on record our sincere thanks to our project supervisor Prof. Dr. P. Ravibabu, Department of EEE, Sreenidhi Institute Of Science and Technology for his valuable help and co-operation rendered by him for completion of my project work.

#### REFERENCES

- [1] A literature survey of 'solar water pump' by Ibrahim alkhubaiji of IJERA.
- [2] A literature survey of 'solar PV array FOC scheme' by U.sharma of research gate.
- [3] [solarmagazine.com](http://solarmagazine.com)



10.22214/IJRASET



45.98



IMPACT FACTOR:  
7.129



IMPACT FACTOR:  
7.429



# INTERNATIONAL JOURNAL FOR RESEARCH

IN APPLIED SCIENCE & ENGINEERING TECHNOLOGY

Call : 08813907089  (24\*7 Support on Whatsapp)