



IJRASET

International Journal For Research in
Applied Science and Engineering Technology



INTERNATIONAL JOURNAL FOR RESEARCH

IN APPLIED SCIENCE & ENGINEERING TECHNOLOGY

Volume: 9 Issue: VI Month of publication: June 2021

DOI: <https://doi.org/10.22214/ijraset.2021.35551>

www.ijraset.com

Call:  08813907089

E-mail ID: ijraset@gmail.com

A Review on Smart Pendent

Deepak A. Pashine¹, Dhiraj A. Thakre², Nutan R. Deode³, Mayur Pandharkar⁴, Akash A. Kohad⁵, Sayali S. Raut⁶, Dr. Rajendra Rewatkar⁷

^{1, 2, 3, 4, 5, 6} B. E Student, ⁷Associate Professor Department of Electronics Engineering, Rashtrasant Tukdoji Maharaj University, Nagpur, Maharashtra, India

Abstract: *The world is facing a dangerous pandemic and it is a transmissible virus that infects people who came in contact with the infected person and with the things used by them. Many industries see huge economic losses, and businesses are going ruined. Although, unlock process is started still many industries facing problems due to the increasing rate of Covid positive patients, it is not possible to close working after the detection of individual positive employees. Also, it is difficult to find contacted employees with Covid positive employees. It became a challenging task to find out how many people came in contact with the infected people. So, to make this process somehow easy we have designed a small device. In this paper, we have described the smart pendent a small device that helps to detect how many people come in contact with the coronavirus infected person. It is a wearable RF device in the form factor of a Pendant, suitable for powering a smart Rf device. An experimental comparison between multistage Cockcroft-Walton and Dickson RF-DC converters shows that the Dickson topology offers higher efficiency at high input power, whereas the Cockcroft- Walton converter performs better for low input power. The pendant can produce up to 23.2 μ W at 10.4 m from a commercial isotropic 3 W RF power transmitter.*

Keywords: RF technology, ATmega, UVC band, technology for disinfection

I. INTRODUCTION

The global population is in front of the deadly coronavirus diseases. This disease is caused by the virus named coronavirus which has the same symptoms as viral fever, cough, etc. but it attacks some internal organs also such as respiratory organs, and makes them weak. This virus is transmissible and can infect one person to another. If any person comes in contact with the infected person or the things used by the infected person he or she gets infected. Also, it was a difficult task to find out how many people came in contact with the infected person. Hence UNO guided to lockdown countries where there is a red zone to break the coronavirus chain. This affected economic sectors like industries, MNC's, banks, etc. Many industries see enormous financial sufferers, and businesses are going penniless. The process of work from home started. This made huge losses for the companies. Then the question arises if there was something, some device which helps to detect how many people come in contact with the infected employee it would be easy in place of telling all the employee to work from home only the people who were in contact will be made to work from home. And the other entire employee can continue to work from the office itself. So, to make this process somehow easy we have designed a small device „Smart Pendent“. It is a wearable device and small in size. This device works on the RF transmission, MySQL server to store data and battery. This device consists of two sections transmitter section and the receiver section. When two employees having smart pendant comes close in contact it will automatically transmit a signal having the name and identity of the user to other pendent and this signal will be received by the other pendent and the data will be saved in the main server which is managed by the control room of the office. In this way, all the employee's data who came in each other contact will be saved on the server. And if any employee got infected due to coronavirus. The thing only to do will be just checked with whom he or she came in contact and take action needed. This device is effective and efficient. It is powered by a battery.

II. LITRETURE REVIEW

- A. This paper explains the protocol to be used is ZigBee communication Protocol with the IoT service. IoT connect anything on the internet using a specific protocol with sensors, devices, equipment to transfer the information and to communicate among devices intelligently to achieve smart monitoring and administration.
- B. This paper deals with the popular wireless communication standards, evaluating their main features and behaviors in terms of various metrics, including the transmission time, data coding efficiency, complexity, and power consumption. It is believed that the comparison presented in this paper would benefit application engineers in selecting an appropriate protocol.

- C. This paper explains establishment of a realistic indoor environment for the performance evaluation of a 51- node ZigBee wireless network. Several sets of practical experiments have been conducted to study its various features, including the (1) node connectivity, (2) packet loss rate, and (3) transmission throughput. The results show that our developed ZigBee platforms could work well under multihop transmission over an extended period of time.
- D. This paper reviews a gateway-based inter-PAN binding mechanism for global event detection and action invocation. By collecting device capabilities from each intra-PAN gateway, an inter-PAN gateway is used to create a binding specification. Once all events defined in the binding specification are received from related intra- PAN gateways, the inter-PAN gateway would initiate corresponding actions on all associated intra-PAN gateways. To demonstrate the practicality, an inter-PAN binding system for ZigBee sensors and actuators has been implemented based on the universal plug and play (UPnP) and representational state transfer (REST) Web services for intra-PAN gateway discovery and device capability collection. Also, a Web-based wizard has been provided to create binding specification. It is believed that the technique presented in this paper would enable the interaction between ZigBee PANs to perform wide-ranging WSN applications.
- E. This paper analyses the performance of IEEE 802.15.4 Low-Rate Wireless Personal Area Network (LR- WPAN) in a large-scale Wireless Sensor Network (WSN) application. To minimize the energy consumption of the entire network and to allow adequate network coverage, IEEE 802.15.4 peer-to-peer topology is selected, and configured to a beacon-enabled cluster-tree structure. The analysis consists of models for CSMA-CA mechanism and MAC operations specified by IEEE 802.15.4. Network layer operations in a cluster-tree network specified by ZigBee are included in the analysis. For realistic results, power consumption measurements on an IEEE 802.15.4 evaluation board are also included. The performances of a device and a coordinator are analyzed in terms of power consumption and goodput. The results are verified with simulations using Wireless Sensor Network Simulator (WISENES). The results depict that the minimum device power consumption is as low as 73 μ W, when beacon interval is 3.93 s, and data are transmitted at 4 min intervals. Coordinator power consumption and goodput with 15.36 ms CAP duration and 3.93 s beacon interval are around 370 μ W and 34 bits/s

III. BLOCK DIAGRAM

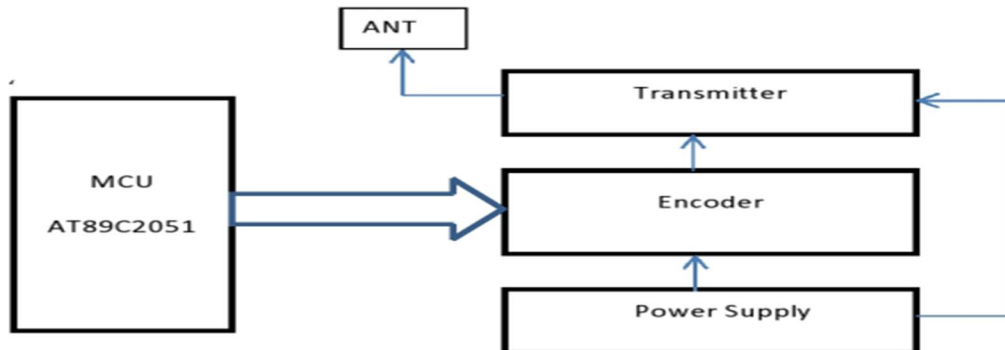

Fig 1. Block Diagram Smart Pendant Transmitter Section

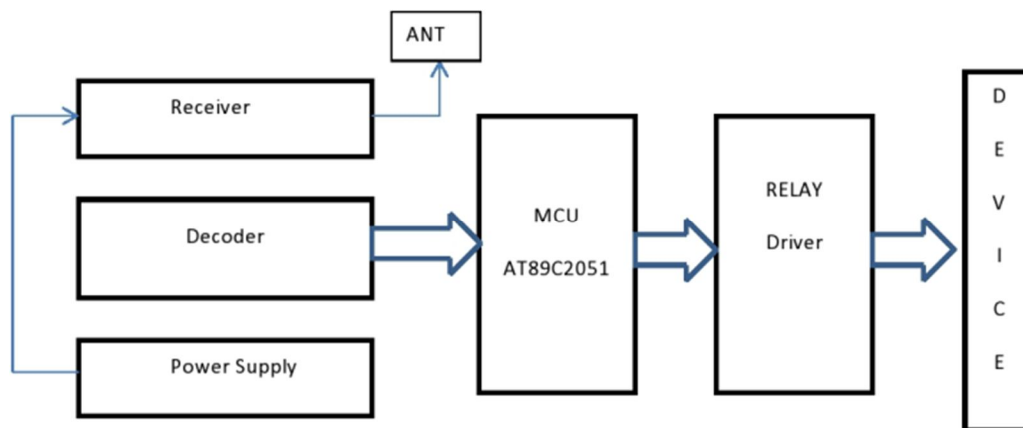

Fig 2. Block Diagram Smart Pendant Receiver Section

IV. OPERATION

The Smart pendant is divided into two parts transmitter section and the receiver section. The transmitter section consists of a transmitter, encoder, power supply, and transmitting antenna, and all the operations are controlled by MCU. The receiver section consists of the receiver, encoder, power supply, relay driver, and receiving antenna. The smart pendant has both a transmitter and receiver section. When one pendant comes in the nearby range it will alert the pendant automatically and starts the operation of exchanging the identity data. This data is then processed and sent to the server data room where it is saved for further process. If any employee gets infected then just enter details of the employee in the application and find out with how many people he or she came in contact with and take the required action as early as possible. All the data is saved in the server and can be accessed by the application linked with it.

V. CONCLUSION

This paper describes the smart pendant a small device that is used for finding with whom and how many people a coronavirus infected person came in contact with. This will make the detection process easy and the management can take required action as early as possible. Thus the employees except infected employees can work in an office and this will maintain the discipline of the office as well as the economic growth.

REFERANCES

- [1] Syed Sultan Mahmood, Pramod Sharma, "IoT Based Industrial Automation using Zigbee communication standard", International Journal Of Innovative Technology and Exploring Engineering, Volume-9 Issue-4, February 2020.
- [2] J. S. Lee, Y. W. Su, and C. C. Shen, "A comparative study of wireless protocols: bluetooth, UWB, ZigBee, and Wi-Fi", 33rd Annual Conference of the IEEE Industrial Electronics Society (IECON'07), pp. 46–51, Taipei, Taiwan, November 2007.
- [3] J. S. Lee, C. C. Chuang, and C. C. Shen, "Applications of short-range wireless technologies to industrial automation: a ZigBee approach", 5th Advanced International Conference on Telecommunications (AICT'09), pp. 15–20, Venice, Italy, May 2009.
- [4] C. H. Wu, H. S. Liu, Y. F. Lee, M. S. Wei, Y. J. Li, and J. S. Lee, "A gateway-based inter-PAN binding mechanism for ZigBee sensor networks", 37th Annual Conference on IEEE Industrial Electronics Society (IECON'11), pp. 3808–3813, Melbourne, Australia, November 2011.
- [5] M. Kohvakka, M. Kuorilehto, M. Hännikäinen, and T. D. Hämäläinen, "Performance analysis of ZigBee for large-scale wireless sensor network applications", 3rd ACM International Workshop on Performance Evaluation of Wireless ad hoc, Sensor and Ubiquitous Networks (PE-WASUN'06), pp. 48–57, Torremolinos, Spain, October 2006.
- [6] H. López-Fernández, P. Macedo, J. A. Afonso, J. H. Correia, and R. Simões, "Performance evaluation of a ZigBee-based medical sensor network", 3rd International Conference on Pervasive Computing Technologies for Healthcare (PervasiveHealth'09), pp. 1–4, London, UK, March 2009.
- [7] G. Anastasi, M. Conti, M. Di Francesco, and V. Neri, "Reliability and energy efficiency in multi-hop wireless sensor networks", 15th IEEE Symposium on Computers and Communications (ISCC'10), pp. 336–341, Riccione, Italy, June 2010.



10.22214/IJRASET



45.98



IMPACT FACTOR:
7.129



IMPACT FACTOR:
7.429



INTERNATIONAL JOURNAL FOR RESEARCH

IN APPLIED SCIENCE & ENGINEERING TECHNOLOGY

Call : 08813907089  (24*7 Support on Whatsapp)