



IJRASET

International Journal For Research in
Applied Science and Engineering Technology



INTERNATIONAL JOURNAL FOR RESEARCH

IN APPLIED SCIENCE & ENGINEERING TECHNOLOGY

Volume: 9 Issue: VI Month of publication: June 2021

DOI: <https://doi.org/10.22214/ijraset.2021.36027>

www.ijraset.com

Call:  08813907089

E-mail ID: ijraset@gmail.com

Three-Phase Fault Analysis on Transmission Line in Matlab Simulink

Harshal Vilas Patil¹, Prof. Pratik Ghutke²

¹(Mtech EE), ²Department of Electrical Engineering, Tulsiramji Gaikwal patil collage of engineering & technology, Nagpur

Abstract: *Now-a-days the demand of electricity or power are increases day by day this results to transmits more power by increasing the transmission line capacity from one place to the other place. But during the transmission some faults are occurred in the system, such as L-L fault (line to line), 1L-G fault (single line to ground) and 2L-G fault (double line to ground).*

These faults affect the power system equipments which are connected to it. The main aim of this paper is to study or analysis of faults and also identifies the effect of the fault in transmission line along with bus system which is connected to transmission line. Mainly the major faults in long transmission lines is (L-G) single line to ground fault which are harmful to the electrical equipment.

A proposed model in transmission line is simulated in MATLAB software to analysis and identified the faults. Fault block was taken from the sim-power system block library. The whole modeling and simulation of different operating and different conditions offault on transmission line, their faults are L-G fault, 2L-G fault, 3L-G fault and three line short circuit of the proposed work is presented in this paper.

Keywords:

L-L- Line to Line fault,

1L-G - Single Line to Ground fault,

2L-G Double Line to Ground fault

I. INTRODUCTION

When different types of fault occurs in power system then in the process of transmission line fault analysis, determination of bus voltage and the rms line current are possible. While consulting with the power system the terms bus voltage and rms current of line are very important. In case of three phase power system mainly two faults occurs, three phase balance fault and unbalance fault on transmission line of power system, such as line to ground fault, double line to ground fault and double line fault. The transmission line fault analysis helps to select and develop a better for protection purpose [1].

For the protection of transmission line we place the circuit breakers and its rating is depends on triple line fault. The reason behind is that the triple line fault current is very high as compare to other fault current. Hence by using MATLAB simulation in computer, the analysis of transmission line fault can be easily carried out.

The main purpose of this paper is to study the general fault type which is Unbalance faults of transmission line in the power system. Also to perform the analysis and obtain the Result of various parameters (voltage, current, power etc) from simulation on those types of fault Using MATLAB.

A new modeling framework for analysis and simulation of unbalance fault in power system is Procedure includes the frequency information in dynamical models and produces approximate non linear Models that are well adopted for analysis and simulation. The transformer model includes Saturation.

The parameters have been obtained from practical or experimental measurement. From the study it is seen that sags can produce transformer saturation when voltage recovers. This Leads to produce an inrush current that is similar to inrush current produced during the transformer Energizing. The study point out that the voltage recovery instant can take only discrete value, since the fault-clearing is produced in case of natural current zeroes [2]. The instant of voltage recovery Corresponds to the instant of fault clearing. For phase to phase fault and single phase fault, a single point-on-wave of voltage recovery can be defined. On the other hand for two-phase-to-ground and Three-phase fault, the recovery takes place in two or three steps [3]. In petrochemical industry, the Grounding and ground fault protection are very important factors. For that first it is important to have the proper system grounding for the particular system application, and along with this it is usually important to have the proper production against the ground fault.

II. LITRUTURE REVIEW

Normally, a power system operates under balanced conditions. When the system becomes unbalanced due to the failures of insulation at any point or due to the contact of live wires, a short circuit or fault is said to occur in the line. faults may occur in the power system due to the number of reasons like natural disturbances (lightning, high-speed winds, earthquakes), insulation breakdown, falling of a tree, bird shorting, etc. Faults that occur in transmission lines are broadly classified as:

- 1) Symmetrical faults
- 2) Unsymmetrical faults

A. Unsymmetrical Faults

As discussed above in three-phase transmission line of power system mainly two types of fault occur, balanced fault which is also called symmetrical fault and unbalanced fault called as unsymmetrical fault. But this paper only deals with the unsymmetrical. Unsymmetrical faults are the faults which lead to unequal currents with unequal phase shifts in a three-phase system. The unsymmetrical fault occurs in a system due to the presence of an open circuit or short circuit of transmission or distribution line. It can occur either by natural disturbances or by manual errors. The natural disturbances are heavy wind speed, ice loading on the lines, lightning strokes and other natural disasters [4]. The open circuit or short circuits of transmission or distribution lines will lead to unsymmetrical or symmetrical faults in the system. In case of tree branches falling on lines, a short circuit of transmission lines will occur. These line faults are classified as

- 1) Single line to ground faults (LG fault)
- 2) Double line fault (LL fault)
- 3) Double line to ground fault (LLG fault)

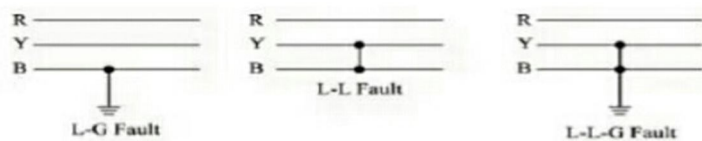

Figure 1

Single line to ground fault is the most frequently occurring fault (60 to 75% of occurrence). This fault will occur when any one line is in contact with the ground. Double line fault occurs when two lines are short-circuited. This type of fault occurrence ranges from 5 to 15%. Double line to ground fault occurs when two lines are short-circuited and are in contact with the ground. This type of fault occurrence ranges from 15 to 25% of occurrence.

B. Causes of Fault in Power System

- 1) Lightning strokes cause most faults on high-voltage transmission lines producing a very high transient that greatly exceeds the rated voltage of the line.
- 2) This voltage usually causes flashover between the phases and/or the ground creating an arc.
- 3) Since the impedance of this new path is usually low, an excessive current may flow.
- 4) Faults involving ionized current paths are also called transient faults. They usually clear if power is removed from the line for a short time and then restored [5].

C. Need of Fault Analysis in Power System

- 1) Electric systems occasionally experience short circuits.
- 2) This results in abnormally high currents.
- 3) Over current protective devices should isolate faults at a given location safely, with minimal damage.
- 4) The parts of the system shall be able to withstand the resulting mechanical and thermal stresses.
- 5) The magnitudes of fault currents are usually estimated by calculations.
- 6) The equipment is selected using the calculation results.

D. Fault Limiting Devices

It is possible to minimize causes like human errors, but not environmental changes. Fault clearing is a crucial task in power system network. If we manage to disrupt or break the circuit when a fault arises, it reduces the considerable damage to the equipments and also property. Some of these fault limiting devices include fuses, circuit breakers, relays, etc. and are discussed below [6].

- 1) Fuse
- 2) Circuit Breaker
- 3) Relay
- 4) Lighting power protection devices

III. METHODOLOGY

- 1) Project we were perform on IEEE 14 bus system without TCSC observe the voltage ,active power and reactive power waveform.
- 2) Connect the TCSC with IEEE 14 bus system and observe the voltage , active ,and reactive waveform.
- 3) Create the Three phase fault on IEEE 14 bus system and observe the effect of fault on 14 bus voltage waveform.
- 4) IEEE 14 bus system with three phase fault and TCSC connected it is observed that simulation result output TCSC improve the voltage stability and power flow control in power system network.

A. IEEE 14 Bus System

We were perform on IEEE 14 bus system having 14 bus and 20 lines. The system consists of 5 synchronous machine three of which are synchronous condenser and 2 synchronous generators. There are 11 loads in the system having net real and reactive power demand 259 MW and 81.1 MVAR, Respectively. The 14 system has been shown in figure.

B. Circuit Diagram

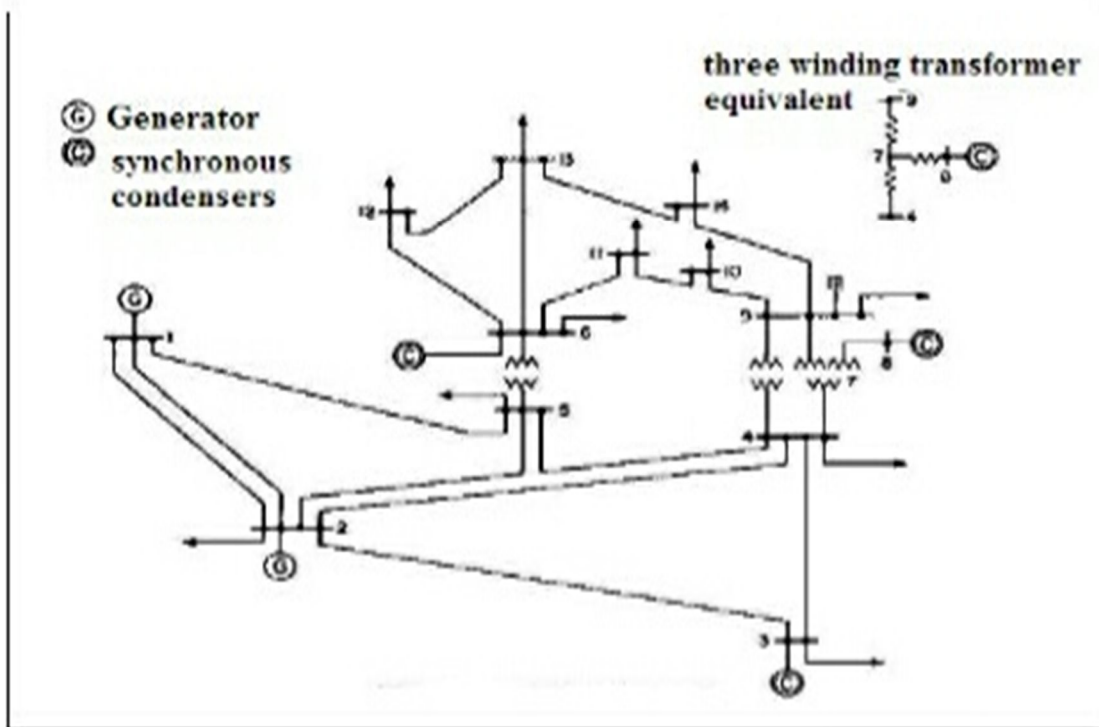

Fig. Single line diagram of IEEE 14 bus system

C. Simulink Model Description

1) IEEE 14 bus system without TCSC

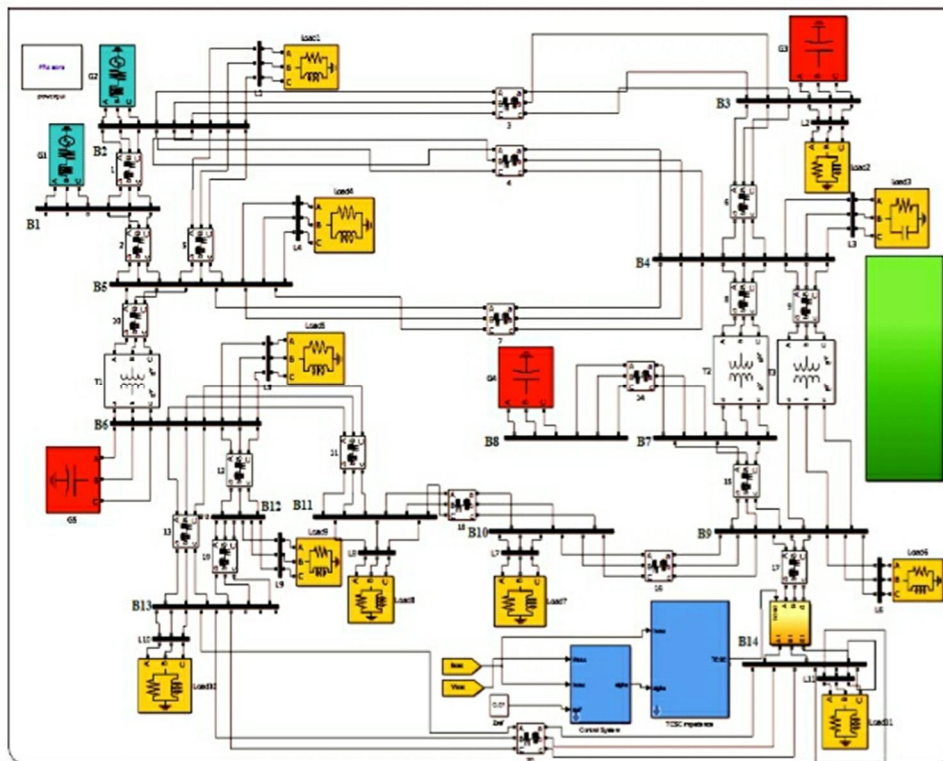

Figure 1: IEEE 14 bus system without TCSC

Project were perform on IEEE 14 bus system Having 14 buses and 20 line .the system consist of synchronous machine three of which are synchronous condensers. There are 11 loads in the system having net real and reactive power demand of 259 MWand 81.3 MVAR. Respectively.

2) IEEE 14 bus system with TCSC

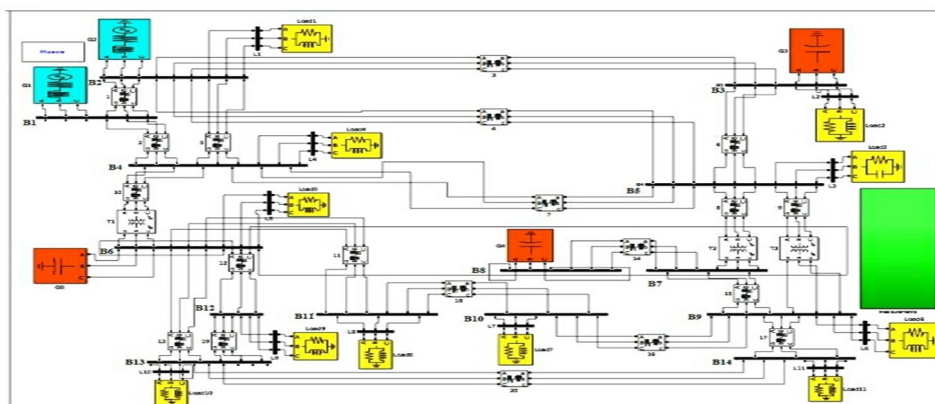

Figure 2: IEEE 14 bus system with TCSC

Figure 2 show the simulink model of IEEE 14 bus system with TCSC . TCSC connected to bus 14 . When TCSC operates in the constant impedance mode it uses voltage and current feedback for calculating the TCSC impedance. The reference impedance indirectly determines the power level, although an automatic power control mode could also be introduced.

3) IEEE 14 bus system with Three Phase Fault

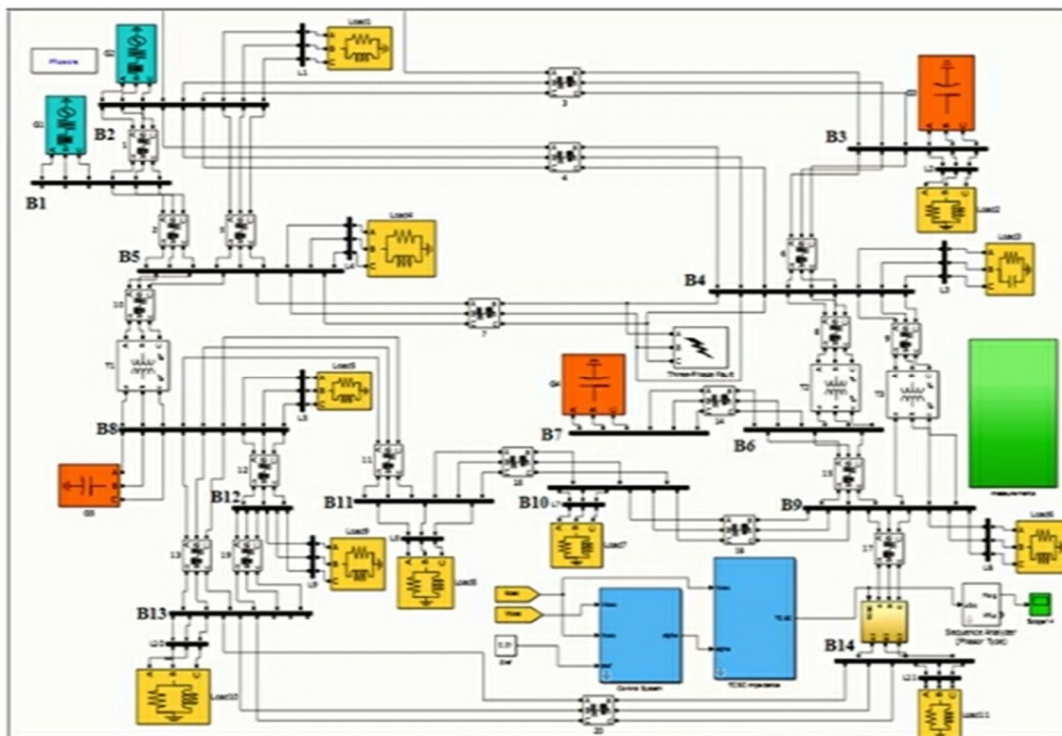

Figure 3: IEEE 14 bus system with Three phase fault.

Figure 2 show the simulink model of IEEE 14 bus system with Three phase fault .three phase fault created in between bus 4 and bus 5 for time duration of 10.00 to 10.05 sec.

4) IEEE 14 bus system with three phase fault and with TCSC

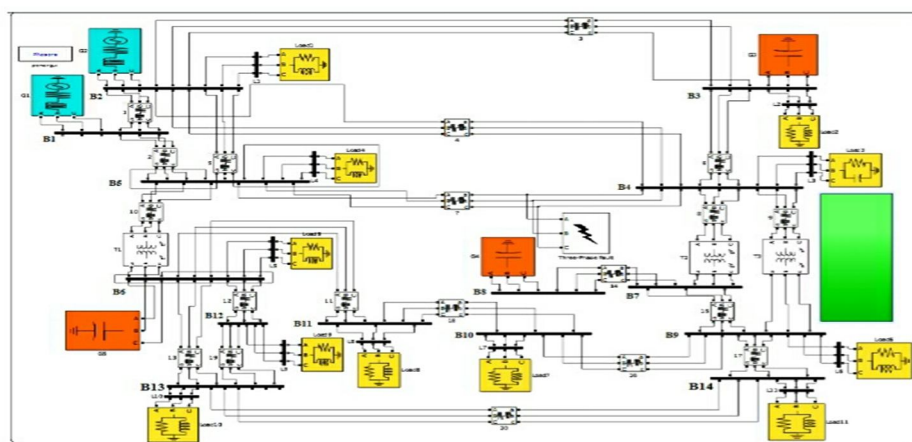

Figure 4: IEEE 14 bus system with Three phase fault with TCSC.

Figure 4 show the simulink model of IEEE 14 bus system with Three phase fault with TCSC .whenever fault occur in power system then TCSC improve the voltage stability and control the power flow in power system network.

Fig. Circuit diagram of 14 bus system in TCS

IV. CONCLUSION

In this dissertation, IEEE 14 bus system with 3 phase fault observe and TCSC FACTS controller is use to limit the fault and improve the voltage stability and power flow control in power system network .We reach at the conclusion that TCSC is one of the fast acting power electronic controller which can provide a smoothly variable series capacitive reactance. this is a new approach 14 bus system with TCSC to improve the voltage stability, limit fault and power flow control in power system network . IEEE 14 bus system with and without TCSC, comparative result and simulation result waveform show that, using TCSC we can improve the voltage stability and power flow control in power system network.and also limit the three phase fault

REFERENCES

- [1] Narain G. Hingorani and Laszlo Gyugyi, "Understanding FACTS Concepts and Technology of Flexible AC Transmission Systems", IEEE press, 2000
- [2] D. K. Tanti, M.K.Varma, Brijesh singh , O.N. Mehrotra, "Optimal Placement of Custom Power Devices in Power System Network to Mitigate Voltage sag under Fault," International Journal of power electronics Drive and system(IJPEDS), Vol. 2, Issue 3, September 2012, pp 267-275.
- [3] Venu Yarlagadda, Dr. B.V. Sankar Ram, Dr K.R.M. Rao,"Voltage Stability Improvement using Thyristor Controlled Series Capacitor (TCSC) based on Lmn and VCPI Stability Indices ," International Journal of scientific and Engineering Research , Vol. 3, Issue 4, April 2012,pp 1-5.
- [4] Manisha chadar , "Comparison of thyristor controlled series capacitor and discrete PWM generator six pulses in the reduction of voltage sag ,," International Journal of enhance research in science technology and engineering , Vol. 2, issues. 8, August 2013, pp 24-29.
- [5] Shrawan Ram, G.K. Joshi,"Power Flow Control using TCSC Facts controller," International Journal of computer application (IJCA), 2014 ,pp 23-27.
- [6] D.Jovcic, Member, IEEE and G.N. Pillai, "Analytical modelling of TCSC Dynamics" IEEE.
- [7] Sandeep Gupta, Prof. R. K. Tripathi, Member, IEEE, and Rishabh Dev Shukla" Voltage Stability Improvement in Power Systems using Facts Controllers : state- of the Art Review" IEEE .
- [8] K. R. Padiyar, "FACTS Controller in Transmission and Distribution System",
- [9] P.S.Chaudhari, P. P.Kulkarni, R.M.Holmukhe, Mrs.P.A.Kulkarni , "TCSC for protection of transmission line",IEEE.
- [10] Martin German-Sobek, ubomír Be, a, Roman Cimbala, "Using of the Thyristor Controlled Series Capacitor in Electric Power System", ELEKTROENERGETIKA, Vol.4, No.4, 2011, pp 11-15.
- [11] Kusum Arora, Dr. S. K. Agrawal, Dr Narendra Kumar ,Dharamvir. "Analysis of power flow control in power system network using Thyristor control series Capacitor",International journal of Engineering Research and Application (IJERA), Vol.3, Issue 3, Jun2013, pp 821-825.
- [12] J.V. Kadia, J.G. Jamnani , "Modelling and Analysis of TCSC Controller For Enhancement of Transmission Network", International Journal of Emerging Technology and Advanced Engineering, Vol.2, Issue.3, March 2012, pp 229-223.
- [13] Adebayo,I.G., Adejumbi, Olajire, O.S., "Power flow Analysis and voltage stability Enhancement Using Thyristor controlled Series Capacitor(TCSC) Facts Controller",International Journal of Engineering and Advanced Technology (IJEAT), Vol.2, Issue 3, February 2013, pp 100-104.
- [14] Shobhna patlay , Bhupesh Kumar Poosam, "How TCSC Controller Benefits AC Transmission line for voltage stability", International journal of Scientific Research , Vol.3, Issue 8, August 2012, pp 1-3.
- [15] Anita Kanwar, Rachit Sexena, "Behavior of TCSC in Transmission line using MATLAB /Simulation", International journal of Innovative research in Electrical ,Electronics ,Instrumentation and control Engineering, Vol.3, issue 5 , May 2015, pp 195-197.
- [16] Pravin Sonwane, Pratik Ghutke "Real-Time Implementation of an Automated Irrigation System for Effective Water Application to Improve Productivities of the Crop in India" Journal of The Institution of Engineers (India): Series A, Volume 101 Issue 3 page 485-493, Springer India. <https://doi.org/10.1007/s40030-020-00451-7>.



10.22214/IJRASET



45.98



IMPACT FACTOR:
7.129



IMPACT FACTOR:
7.429



INTERNATIONAL JOURNAL FOR RESEARCH

IN APPLIED SCIENCE & ENGINEERING TECHNOLOGY

Call : 08813907089  (24*7 Support on Whatsapp)