



iJRASET

International Journal For Research in
Applied Science and Engineering Technology



INTERNATIONAL JOURNAL FOR RESEARCH

IN APPLIED SCIENCE & ENGINEERING TECHNOLOGY

Volume: 9 Issue: VII Month of publication: July 2021

DOI: <https://doi.org/10.22214/ijraset.2021.36051>

www.ijraset.com

Call:  08813907089

E-mail ID: ijraset@gmail.com

IOT Based Self Vehicle Pollution Checking, Engine Temperature and Fuel Levels with Prediction Alerts

G. Naveen Kumar¹, P. Shashi kumar², T. Vignesh³, Dr. Ameet Chavan⁴

^{1, 2, 3}UG Students, ⁴Professor, Sreenidhi Institute of Science and Technology, Hyderabad, Telangana

Abstract: Pollution detection and ordinary tracking is extraordinarily good-sized errand in this point in time of in our present international. To make a higher and greater steady circumstance for individual, creatures, and plants. We ought to display screen and manage the infection via the Internet of factors innovation. This research proposes air infection and checking version which distinguishes infection in air primarily based totally on statistics mining calculation. The sensor System is used to apprehend the sensor regards from one of a kind fueloline sensors. The microcontroller is applied to trade the features from ADC to server. Information mining is applied to compute the pollution from numerous regions. ID3 set of rules is used to figuring the bottom of the traits on probability. Bluetooth module is applied to interface the controller with the purchaser and the purchaser related to the server via internet administrations. Remote sensors are applied to envision the extent of risky gases gives major all-round that, at last, offers a lower in infection. This framework now no longer simply computes the poisons gift major all-round yet, in addition, we are able to parent to preserve a strategic distance from destiny infection in and might ship the notification message to the particular dirtied location. Here we recall essentially the concoction Industry near Delhi and the metro city groups. These studies paper in particular centered at the evidence of pollutants tracking and locate on precise region or geographical area for an IOT bodily devices that collects statistics with admire to bodily parameters, making use of a complicated microcontroller stage, from one of a kind varieties of sensors, via various techniques of correspondence and after that transfers the statistics to the an internet. The displayed device has been supposed for far flung checking of weather numerous environments. These article facilities across the approach of moving received statistics at the internet with the intention that the device may be applied to remotely display screen weather parameters and in the end take a look at environmental extrade designs like temperature, humidity, Atmospheric Pressure. The paper additionally discusses the simple idea of Internet of Things and its capacity programs, specially for climate tracking.

Keywords – Air Pollution, IOT, Weather, Pollution Real-time far-flung tracking, Arduino, Raspberry Pi, Sensors.

I. INTRODUCTION

This looks at supposed to make a prototype System, which makes use of an embedded gadget making use of raspberry pi for looking the weather interchanges in numerous regions. This prototype talks approximately an looking at System which offers records approximately ecological function on a regularly close by dimension, the execution location is assessed by means of current, domestic and workplace programs and fast contacts the modern headways in checking nature and drawing out the brand-new extension in checking the prevailing circumstance issues. The System should display screen encompassing weather occasions together with stickiness, temperature, mild strength, soil dampness, and precipitation. The gift version and a comparable exam of nature System had been linked in an instance horticultural ranch, already said version System become located to be agreeable for ranchers for viably checking the home anywhere whenever, which ends up from value lower, resource-sparing, and worthwhile management in cultivating. The version System is created making use of open supply device Raspberry pi and WIFI which demonstrates realistic and having low strength utilization. The present sensors are collecting the statistics of various herbal affection and provide it to Raspberry pi, which is going approximately from principal server. The Raspberry pi dispatch the statistics making use of WIFI and the organized statistics might be proven on PC via attending to the server this is at the recipient side. It has a horrible impact on human well-being, amphibian existence and creatures. Pollution in city regions isn't a brand-new issue. The intake of coal has caused infection. Amid foggy situations, the infection transforms into exhaust clouds. Exhaust cloud reasons interruption of site visitors which can also additionally spark off conveyed city groups to a prevent and ascend in demise costs to extensively rise. General Health Act section endeavored to lower smoke infection.

In the 20 th century, better degree of current controls dwindled exhaust cloud infection. Smoke Abatement Act diminishes smoke outflows. Contamination is a bothersome extrade in bodily, concoction or natural features of air. Land or water which impacts the existence of character or makes well-being perils to residing creature. Air infection is a noteworthy chance component for well-being incorporating illnesses in pores and skin and eye.

Aggravation of the nose. Throat and eyes. Coronary illness. Lung malignancy, Bronchitis. Trouble in breathing. The essential drivers of infection are Carbon dioxide (CO₂) fueloline. Changes in ecosystem and weather situations were watched for pretty an extended time. Observing the climate framework versions is vital to decide the surroundings differences. There after which usually massive significance of weather influencing on human existence which had influenced to the improvement of entire clinical regions at the weather and climate observation. In the start there had been easy and misguided contraptions used, which had been insufficient for smooth studying and storing of measured parameters. Nowadays, there are numerous computerized observatories and climate forecasting structures all around the international accumulating the environmental parameters constantly for a number of the alternative programs which indicates the significance of the climate at each day existence. Transmission of the measured records will be completed by means of some of means: WI-FI hyperlink, GSM/GPRS hyperlink, satellite tv for pc hyperlink direct, a stressed-out hyperlink, etc. Weather forecasting must be dependable and accurate, irrespective of its application. Also, it has to offer easy get admission to to all of the measured parameters [1]. The Internet of Things (IoT) has the capacity to make the sector greater hospitable for gift and destiny generations of humanity. IoT gadgets may be deployed in severa approaches for sustainable improvement. The IOT gadgets may be used to degree bodily frameworks concerning a practical item and add them real-time to a web repository i.e. to cloud garage in which they could also be analyzed in realtime. Thus, the measured records may be located from everywhere round the sector the use of Internet-enabled gadgets. IoT, included with cloud computing, permits for decentralization of records garage, processing, and analysis. The gathered records also can be used to robotically manage different far-flung gadgets, the use of machine-to-machine (M2M) verbal exchange via the Internet. The great of sensors and precision of measurements can also additionally vary, and the area/ region of weather or climate forecasting station can determine the exactness and unwavering great of the weather statistics accumulation. As a rule, the patron is confined to the options given by means of the maker. Regardless of whether or not a mild extrade in parameter checking or statistics making ready is watched, the commercial enterprise devices ended up irrelative. For a few precise programs, it's miles required to have bendy and configurable solutions.

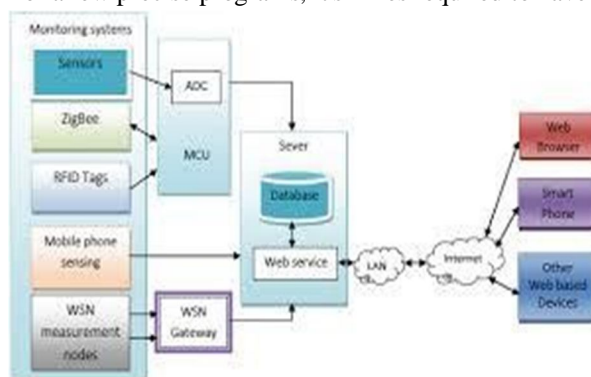

Figure 1: Block Diagram of Operational Procedures

- 1) *Methods:* This proposition altogether decreases the labor, spares time and works effectively beyond own meddling. This undertaking puts out the principal activity in accomplishing the ideal destination. With the approach in innovation, the current arrangements are created to contain inbuilt insight. Here classification will consequently communicate the ongoing location information.
- 2) *Discoveries:* In this undertaking we will watch nature conditions utilizing the brilliant sensors in inserted innovation, utilizing this task we can break down the atmosphere and contamination condition of our encompassing, utilizing this information, we can recoup existing climate from contamination.
- 3) *Applications:* The Arduino as the prime controller which uses ATMEGA328 microcontroller, temperature, dampness, gas, sound sensors are used to recognize nature condition and give the data to the Microcontroller which is used to watch the measurement and send the data to the cloud server by methods for IOT.

Among other things the commercial devices could be too expensive for some applications purposes. This paper deals with the weather forecasting prototype system developed for particular targets. Using relatively inexpensive components, the development of a prototype system for measuring of various parameters like temperature, humidity, lightintensity, rainfall and soil moisture is achieved in existing surrounding air, which could be an inexpensive module used in the agricultural land for the weather monitoring and forecasting the data to the server which could be viewed and used for the periodical statistical analysis of the weather statistical data.

II. EXISTING SYSTEM

From a wellbeing perspective, toxins from substance ventures are a significant factor. Contamination has expanded malignant growth rates, birth abandons and mental impediment. Among different issues with wellbeing. Daylight consolidates oxides of nitrogen with the unstable natural compound in the environment to make ozone. Huge mechanical offices, for example, service stations, pastry kitchens, cleaners can create the toxins. Engine vehicle discharges and stationary sources shaping extremely high centralizations of ozone. The most abnormal amounts of ozone were recorded in Los Angeles. Nitrogen dioxide causes flu causing lung disturbance and respiratory contaminations. Thus, an air contamination checking framework was created to gauge CO, NO₂, and SO₂ and O₃ gasses dependent on a smaller scale converter brilliant sensor that downloads poison levels to a system associated PC. The Smart Transducer Interface module was created utilizing simple gadgets to gather the gas focus level and STIM data that can be seen on the graphical UI. This framework results in the level of air toxins that utilization IEEE 1451 gauges and semiconductor.

A continuous checking is conceivable with remote sensor framework and with the assistance of Bluetooth gadget of harmful ecological unstable natural mixes with the assistance of Bluetooth gadget interface. In numerous enterprises, the unstable natural mixes are utilized that antagonistically influences the earth and human wellbeing. The fundamental wellsprings of VOC are depleting from the motors and can be found in high rush hour gridlock regions amid pinnacle hours. This framework manufactured a gadget which can identify dangerous unstable natural mixes continuously. To screen contaminations noticeable all around a geosensor is utilized comprising of more than 20 sensors and 8 switches. This framework is utilized to detect the contamination and gauge to private or distant zones to give wellbeing rules to human wellbeing. This detected information can be characterized in min, max, mean esteem. To distraction of the dirtied region and the unsafe rate of contamination can be resolved against various contamination counteractive actions prototypical. Against this model we discover two zones, for example, current risky zone and future hazardous region [2]. An epic method for information accumulation which is known as WAPMS. This epic strategy is named as Recursive Converging Quartiles which uses just three characteristics for readings of any length. This reduces the proportion of data to be transmitted to the sink, which controls the transmission imperativeness required and addresses the careful novel characteristics. The database is used to save the accumulated readings which can be gotten to independently as line or diagram.

III. PROPOSED SYSTEM

The various atmospheric conditions in the outside surroundings of the home or any structures are checked and information is transmitted to the cloud server. The inclination is it will regularly transmit the steady information. The information can be found in any bits of the world. This relevance is to watch and ordinarily revive the earth sphere. Condition conditions can be checked and if the ecological status goes irregular, variations from the norm can be refreshed in cloud an important activity to lessen those anomalies should be possible. The climate changes in the out stands of any structures are checked and data are transmitted to the cloud server. The preferences will consequently transmit the ongoing condition information. The data can be found in any pieces of the world. This application is to watch and routinely refresh nature condition. Condition can be observed and if the natural condition goes strange, variations from the norm can be refreshed in cloud and essential activity to lessen those anomalies should be possible [3][7].

A. Air Pollution Monitoring System

Air Pollution checking is an Internet of Things application, which serves too screens the climate state of some area or encompassing and the action can be seen by everyone with the assistance of web. This application is increasingly successful; quick in giving condition. It's very helps the people or Government to collect medicinal activities if the state of the existing climate ends up unusual. Condition checking System gives a strategy to confirm the status and difference occur concluded the encompassing. We use Arduino, Sound sensor, Gas sensor, Temperature Sensor, Humidity sensor, IOT module in this System. The temperature and suddenness sensor will screen and gives bits of knowledge concerning the climatic changes. It is important to cultivating. The gas and sound sensor is used for examining the tainting condition. Now a day, air and clamor contamination makes the environment increasingly defenseless. Utilizing this module, we can identify the contaminated territory and construct attention to the general population for living in the contamination explicitly. Rapidly changes in the existing atmospheric environment coordination can't be characterized precisely, and it might inadvertently be characterized in some cases however utilizing an IOT module we can portray progressively estimated the difference in a situation and it tends to be refreshed in the cloud [2].



Figure.2: Wi-Fi Module

The following are numerous Sensored modules utilized in various systems as:

- 1) *Sensor Module:* This sensor network is connected with large scale nodes of few sensor nodes, which can be used as dynamic tool for collecting information for various utilization supporting multiple positions. Diverse sensor is consolidated in this venture, which has its novel method for information gathering from the existing resources.
 - a) *Temperature Sensor:* This Sensor is the way to peruse heat accurately and too control a heat in a large portion of the applications. These Sensors are the way to peruse temperatures effectively and to control temperature in the vast majority of the applications [1]. This method uses the LM34 series of various temperature sensors.
 - b) *DHT11 Sensor:* The system utilizes the DHT11 mugginess sensors. It offers phenomenal quality, quick reaction, hostile to obstruction capacity and costadequacy. This sensor is incredibly precise on dampness adjustment.
 - c) *Gas Sensor:* The gas goes into the senses concluded the permeable layer into the working cathode where it is oxidized or decreased. This response reviews in an electric flow with the expectation of going through the outer circuit. Thus, it is utilized to recognize the contamination material noticeable all around.
 - d) *Sound Sensor:* This identification gives through ahead methodology to screen sound and is commonly used for distinguishing sound power. This module can be used for security and checking applications. Its precision can be effectively balanced for the use of settlement.
- 2) *Power Module:* The power for the entire method can be utilized by connector or/and USB. An Arduino board can be filled by using the USB interface or with an outer case its electrical supply. Required power resource can be picked subsequently.
- 3) *Controller Module:* An Arduino UNO is the existing controller of existing function, the Arduino board changes over analog information, which is made by the sensor to cutting edge data. Arduino is made to screen or comprehend nature or including by gathering a commitment from various sensors and it can affect its atmospheric information by managing lights, motors, and distinctive actuators. The miniaturized scale controller on the board is modified utilizing the arduino programming language and arduino improvement condition. Arduino ventures can be confined or utilizing they can speak with programming on running on a PC.
- 4) *Internet of Things Modules:* Internet of things board is intended to accommodated an assortment of web/online application necessities with particular points of interest that empower the implanted System architect to effectively, rapidly and flawlessly add web network to their applications, the module's UART refresh highlight and site page control make them ideal for online remote functions, for example, ecological sensors and information from compact battery worked remote sensor arrange gadgets. Lumisense Internet of Things board highlighted with SIM900 GPRS modem or segment to initiate web connection, so furnished with a controller to process all info UART information to GPRS established online information.

B. Software Development

- 1) Wi-Fi setup
- 2) Coding in raspberry Pi
- 3) Multiple Interfacing with the customer – server Python: Python is used for general purpose programming which is free to use and high-level language. Python is an interpreted, interactive, and object-oriented and beginner's programming language, it can run on Linux kernel. IDLE (Integrated Development and Learning Environment) is the special text editor software used for programming in python.

C. Hardware Requirements/Components

- 1) **Improvement board Raspberry PI:** It is a card-sized ARM controlled Linux PC movement board. There are all things considered of 5 sorts of the different board with various confirmation, for the proposed Weather measuring structure Raspberry PI 2 show B is utilized as the fundamental improvement barricade which is appearing in Figure-3 The raspberry pi contains four USB Ports and one 10/100 Base T Ethernet Socket. Forty pins GPIO Header are open in the raspberry pi board which is utilized for join forces with Analog to Digital converter chip (MCP3008) to which the sensors are connected. A 5V Micro USB control port is open to which the power supply is given for the gadget. An HDMI port is available through which interfacing of the screen and the Raspberry Pi ought to be possible and the USB ports for the solace and mouse interfacing. At the last, a Micro SD Card Slot is given where the Micro SD card is to be introduced with the Raspbian Jessie butting programming which dependent on the Linux mastermind. The GPIO pins have indisputable uses openly, for example, control supply, ground, clock, UART interfaces, SPI (progressive fringe interface transport), and so on.
- 2) **MCP3008:** This analog to digital converter, which is a 16 stuck and 8 redirected chip which changes over the straightforward voltages to 10 bit combined code showed up in Figure3. The chip is interfacing with the external clock which is given by the Raspberry pi. LCD Display (16X2) LCD show is a 16 stick module which can be used in two strategy for movement 8 bit and 4 bit assignment. The contraption can moreover be set to a 4 bit mode, which grants sending information in one or more irregularities (or tidbit) of 4 bit, which present to us the mind blowing favored stance of decline number of GPIO affiliations including.
- 3) **Sensors:** Sensors are used for the acknowledgment of the distinctive frameworks in the atmosphere and in soil for the gauging of the atmosphere conditions again and again showed up in Figure-4. Coming up next are the depiction of the sensors in detail.
 - a) **DHT11:** It contains a moistness detecting part, a NTC temperature sensor and an IC on the back of the sensor. The stickiness detecting segment, distinguishing portion has two terminals with dampness holding substrate between them. So as the stickiness changes, the conductivity of the substrate changes or the restriction between these terminals changes which are evaluated and arranged by the IC and sogginess regard is resolved. As the temperature constructs the NTC indoor controller resistance lessens coming about the extension in the yield voltage which by then dealt with by the IC and the temperature regard is resolved.
 - b) **Temperature Sensor (LM35):** This sensor represents a precision IC temperature sensor with its yield in respect to the temperature (in °C). The sensor equipment is fixed and thus it isn't presented to oxidation and distinctive systems. Using the LM35, temperature can be evaluated more accurately than an indoor controller. It in like manner have low self-warming and does not cause more than 0.1 °C temperature climb in still air. The working temperature run is from - 55°C to 150°C. The yield voltage moves by 10mV in light of each °C rise/fall in including temperature, i.e., its scale factor is 0.01V/°C, and the out voltage of the sensor is changed over to the electronic through the ADC chip.
 - c) **Rain Sensor:** The downpour sensor segment is a simple instrument for downpour identification. It will be utilized as a switch when raindrop falls concluded the drizzling panel and furthermore to gauge precipitation power. The module includes, a downpour board and the control board connected to comfort, control pointer LED The simple yield is in the measure of precipitation. Associated with 3.3V/5V control supply and the sensor works dependent on the dimension of the water interfacing the downpour board, the yield voltage of the gadget different on the length of the downpour panel being wet over to computerized based ADC chip.

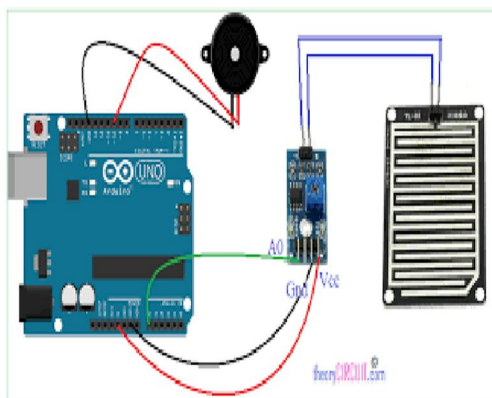

Figure .3: Arduino Rain sensor operational mechanism

e) *LDR-Light Dependent Resistor*: A LDR photograph resistor is a gadget whose resistivity is a component of the occurrence of electromagnetic radiation. These are comprised of semiconductor materials having high opposition. Its opposition under typical lighting is roughly 10K Ohm, while in obscurity these increments to over 2MOhm. When there is heaps of exact light concentrating on the LDR it results in a small obstruction, bringing about the yield voltage dropping towards 0V. When it is dull the LDR opposition increments bringing about the yield voltage expanding towards 3.3V and the different yield voltages are changed over to advanced based ADC chip.

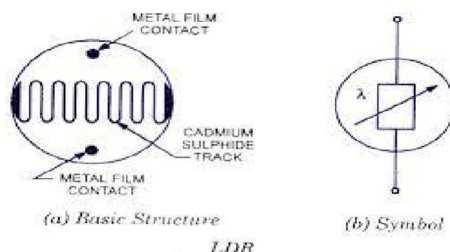

Figure.4: Light Dependent Resistor (LDR)

The proposed inserted gadget is for observing temperature, humidity, and pressure, light force, sound and power levels and CO, CO2 levels in the climate to make the atmospheric keen or intelligent with the items ended remote correspondence. The proposed model has appeared in figure.2 which is progressively versatile and distributive in nature to screen the ecological frameworks.

f) *Carbon Monoxide (CO) Sensor*: CO Sensor fitting for recognizing CO concentrates observably all around, the MQ-7 can perceive CO-gas concentrates some place in the scope of 20 to 2000ppm. This sensor has a high affectability and snappy response time. The sensor's yield is a straightforward resistance. The drive circuit is extremely straightforward; you should simply control the warmer curl with 5V, include a heap obstruction, and associate the yield to an ADC.



Figure 5 : CO Sensor

A tag has a recognizable proof (ID) number and a memory that stores extra information, for example, maker, item type, ecological factors, i.e, temperature, dampness, and so forth.. The peruser can peruse and additionally compose information to labels by means of remote transmissions. In a run of the mill RFID application, labels are appended or installed into articles that need ID or following. RFID labels can be ordered into three noteworthy classes by their capacity source: dynamic labels, inactive labels, and semialoof (semi-dynamic) label. Cell phones or advanced mobile phones that are empowered with sensors are utilized for ecological development by detecting at the right time portable innovation must be utilized for ecological ensuring, detecting and to impact in the nick of time data to make developments and activities natural well disposed of [7].

The portal goes about as the system facilitator responsible for hub validation, message buffering, where you can gather, process, break down and current your estimation information. Remote sensor arranges the executives model comprises of end gadget, switch, portal hub, and the board observing focus. The end gadget is in charge of gathering remote sensor organize information and sending them to the

parent hub, at that point information are sent to the entryway hub from the parent hub straightforwardly or by a switch. In the wake of getting information from the remote sensor organize, the passage hub extricates information subsequent to investigating and bundling them into ethernet group information, sends them to the server.

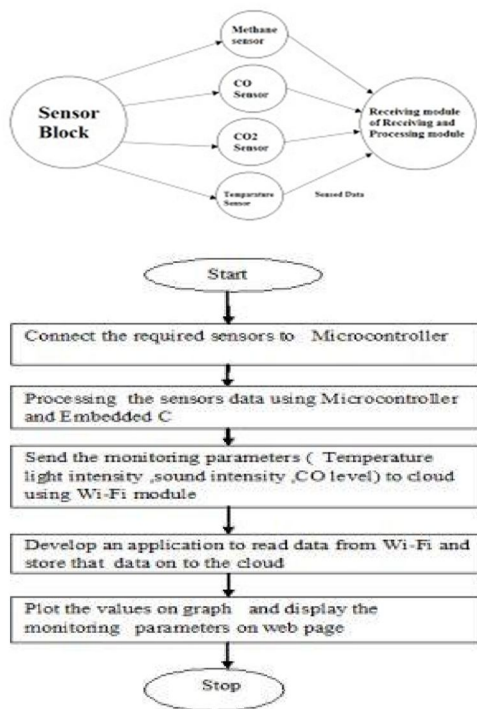

Figure. 6: Sensor identified and Figure. 7: Flow Chart

A server is an example of PC necessary acts a particular acknowledges and reacts to demands made by another program; known as a customer. Less formally, any PC that runs server programming could be viewed as a server also. Servers are utilized to oversee organize assets. The administrations or data in the servers are given concluded the internet a certain are communicated in the bag LAN and made accessible for number of clients by means like a client- server architecture procedure, for example internet access by number of clients from server. Industrialization and urbanization has prompted across the board issues identifying with condition contamination of water, air and land. Industrialization has additionally prompted contamination in the above zones. The ecological obligation and laborer security ought to be the prime saying of any industry alongside profitability and proficiency. This model (Fig.1) is for identifying those unsafe poisonous gases and demonstrates the continuous checking of the centralization of the gases in the mechanical floor [3]. This idea utilizes three gas sensors in particular:

MQ-6, MQ-7, MQ-135 and furthermore utilizing the DHT11 (temperature and humidity) sensor. The sensors can be inserted in tops, caps or wrist watches which can be worn by laborers. The presentation of adaptable, light weight sensors can additionally help up the execution [5]. The thought can be acknowledged by presenting Raspberry-pi and IoT shield .The aim of this paper is to detect the dimension of different gases in the modern floor and transfer this information to the Google spread sheet. Additionally it gives the notice caution if the dimension of gases surpasses as far as standards [8].

With IoT Shield, gadget makers, System integrators and IoT arrange administrators can quickly verify and validate with manage gadgets, with no requirement for any security ability, no continually improvement and testing assets and no change to the application code or gadget functionality. The IoT Shield gives response for different layers of utilization level security and is perfect for assurance of multiple gateways, Industrial utilized PCs and Linux-based edge gadgets. IoT shield counteracts harm to gadget activity and protections associated IoT arrange parts in their exist environment. The API (Application Process Interface) can be empowered which fills in as a medium between the Raspberry-Pi and the Google server or any cloud server. It likewise gives the authorization to the sensor to compose the readings on the Google cloud web server by sharing the customer email id from the (.json envelope) which can be downloaded subsequent to empowering the API for Google spread sheet [5].

MQ-6/7/135 GAS Sensors is one of semiconductor Gas Sensor (Fig. 2) that can be utilized for discovery of gases for the most part utilized for workshops and business structures. This has numerous highlights, for example, High affectability, Fast reaction, Wide recognition extend, Stable execution and long life, Simple drive circuit. Opposition estimations of these sensors contrast with different groupings of gases. Along these lines, when utilizing this part, affectability change is extremely vital.

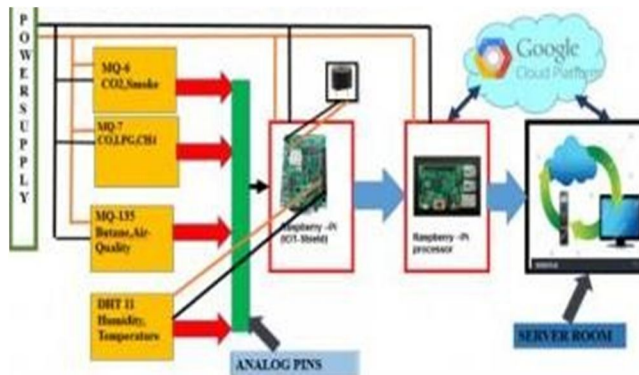

Figure.8: Physical view of the hardware setup

As an elective answer for networking, intelligent routing algorithms which can boost arrange lifetime and alter transmission power can be considered. Upgraded load adjusting and versatile power banks can improve the execution of multihop systems as of vitality.

IV. RESULTS

The proposed plan can be utilized to screen a specific territory of an industry and to gauge the air quality. The nearness of various poisonous gases can be checked. This paper, for the most part, centers around estimating gases like Carbon Monoxide (CO) and Liquefied Petroleum Gas (LPG), Methane, Butane, and Air Quality. A trial setup was created to gauge the gases. The sensor information acquired were gathered and transferred in the Google spreadsheet (Fig. 9).

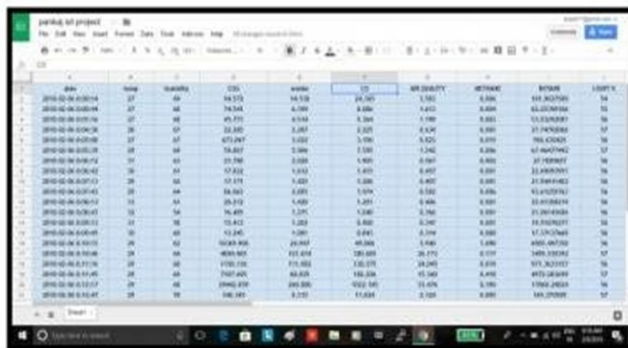

Figure.9: Google spread sheet (sample readings)

The variety in the convergence of different gases can be plainly examined from the Google spread sheet which can be derived to by approved people from any part of the globe (Fig.3). Plots can likewise be acquired to show the varieties at various timespans (Figure. 10,11). Investigations were directed under controlled conditions and can be utilized in any constant situation.

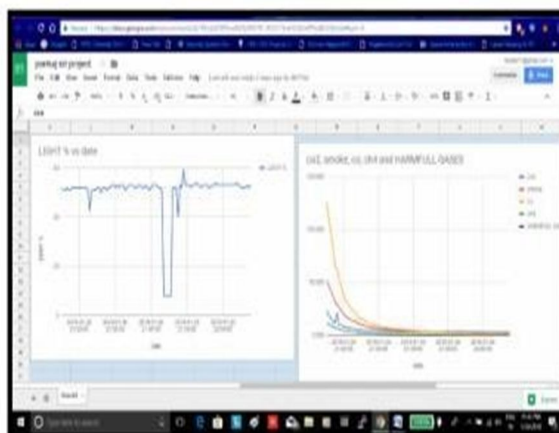

Figure 10: Variation in concentration of various gases.

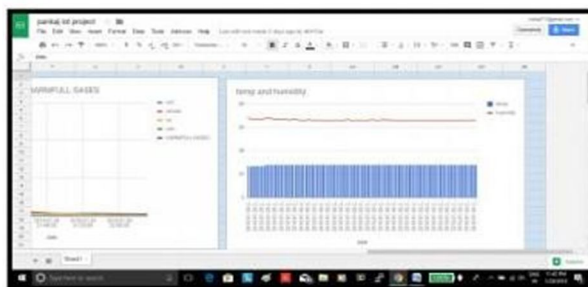

Figure 11: Temperatures and Humidity

This mechanism provides ongoing data about the dimension of air contamination in various areas just as gives alarms in instances of radical change in the nature of air. In light of these readings, such data would then be able to be utilized by the specialists to take brief activities, for example, emptying individuals or sending a crisis reaction group. The plan can be improved by adding a remote system card to the microcontroller hardware for better and simpler control of the sensors readings.

V. CONCLUSION

These method completely monitors and identifies the progressions occurring over the current geographical location and gives adequate approaches to the clients to get to the data from anyplace through a cloud storage. The temperature and dampness sensor, contamination sensors will screen and gives insights regarding the progressions occurring over the atmosphere, these gases and sound sensors are utilized for checking the contamination over condition; the monitored situation will be refreshed in the cloud. Information can be seen from any part on the planet. By utilizing this System the customer can consistently screen distinctive ecological parameters with no communication with an extra server. Raspberry Pi itself goes acts as a server. This is effectively done by Raspbian working System. This climate checking System is structured utilizing Raspberry pi is having minimal effort, little size, low power utilization, quick information exchange, great execution, and remote observing. This System has a few confinements; it doesn't have worked in Wi-Fi and inherent Real Time Clock. For systems administration, direct web association must be given. Just as all sensors must be associate specifically to the GPIO header. For future advancement improved rendition of Raspberry Pi board, a System can be utilized. More sensors can be added to grow the System additionally for remote area checking sun oriented board and wind plant can be utilized for providing a capacity to the System.

A System which can screen the spillage of harmful gases and thus the dimension of contamination utilizing Raspberry-Pi and IoT is proposed which can avoid deadly mishaps. By the utilization of MQ135/6/7 gas sensors, the alert gases can be detected an alarm can be given to spare the life of individuals. Raspberry-Pi fills in as the core of this module which controls the whole procedure. Wi-Fi module associates the entire procedure to web and LCD is utilized for the visual output. The utilization of wearable technology innovation is likewise an achievement which can guarantee the security of specialists in the modern floor. The air checking System can help in the advancement of new practices to defeat the issues of exceptionally contaminated regions, which is a noteworthy issue. Its support the fresh innovation and successfully underpins the sound life idea. This setup has additionally a component which empowers individuals to screen the measure of contamination on their cell phones utilizing the application.

REFERENCES

- [1] Folea S. C. & Mois G. 2015. A low-power wireless sensor for online ambient monitoring. *IEEE Sensors Journal*. 15(2): 742-749
- [2] Sandeep V., Gopal K. L., Naveen S., Amudhan A. & Kumar L. S. 2015, August. Globally accessible machine automation using Raspberry pi based on Internet of Things. In: *Advances in Computing, Communications and Informatics (ICACCI)*, 2015 International Conference on. IEEE. pp. 1144-1147.
- [3] Jindarat S. & Wuttidittachotti P. 2015, April. Smart farm monitoring using Raspberry Pi and Arduino. In: *Computer, Communications, and Control Technology (I4CT)*, 2015 International Conference on . IEEE. pp. 284-288.
- [4] Vallikannu R, A.George and S.K.Srivatsa, A Novel Energy Consumption Model using Residual Energy Based Mobile Agent Selection Scheme (REMA) in MANETs. *Proc. 2nd IEEE International Conference on Signal Processing and Integrated Networks (SPIN)*, New Delhi, 2015.
- [5] Savić T. & Radonjić M. 2015, November. One approach to weather station design based on Raspberry Pi platform. In: *Telecommunications Forum Telfor (TELFOR)*, 23rd . IEEE. pp. 623626
- [6] <https://circuitdigest.com/microcontroller-projects/iot-air-pollution-monitoring-using-Arduino>.
- [7] Grzegorz Lehmann, Andreas Rieger, Marco Blumendorf, SahinAlbayrakDAI, "A 3-Layer Architecture for Smart Environment Models"/A model-based approach/Labor Technische University Berlin, Germany 978-1-4244-5328-3/10 © IEEE,2010
- [8] Subhas Chandra Mukhopadhyay et al. *Wearable Flexible Sensors: A Review*. *IEEE Sensors Journal*, July 2017.



10.22214/IJRASET



45.98



IMPACT FACTOR:
7.129



IMPACT FACTOR:
7.429



INTERNATIONAL JOURNAL FOR RESEARCH

IN APPLIED SCIENCE & ENGINEERING TECHNOLOGY

Call : 08813907089  (24*7 Support on Whatsapp)