



# **iJRASET**

International Journal For Research in  
Applied Science and Engineering Technology



---

# **INTERNATIONAL JOURNAL FOR RESEARCH**

IN APPLIED SCIENCE & ENGINEERING TECHNOLOGY

---

**Volume: 9      Issue: VI      Month of publication: June 2021**

**DOI: <https://doi.org/10.22214/ijraset.2021.36053>**

**[www.ijraset.com](http://www.ijraset.com)**

**Call:  08813907089**

**E-mail ID: [ijraset@gmail.com](mailto:ijraset@gmail.com)**

# Signal Detection in Spatially Multiplexed MIMO Systems

Mohan Reddy<sup>1</sup>, Dinesh Reddy<sup>2</sup>, Sai Krishna Modugula<sup>3</sup>, Dr SPV Subba Rao<sup>4</sup>

<sup>1, 2, 3</sup>U.G, IV year Electronics and Communications Department, Sreenidhi Institute of Science and Technology, Hyderabad, Telangana, India

<sup>4</sup>Professor and Head of ECE Department, Sreenidhi Institute of Science and Technology, Hyderabad, Telangana, India

**Abstract:** The transmission of several signals and reception of those signals, it requires the implementation of multiple transmitters at the transmitter side and the multiple receivers at the receiver side. This type of system is called multiple input multiple output (M.I.M.O) system. The M.I.M.O systems will result in obtaining the better use of the available spectrum for transmissions of the different signals in the same spectrum and this makes the M.I.M.O systems most dependable for the wireless communications. But the presence of several signals in the same bandwidth of spatial multiplexing matrix in M.I.M.O systems makes it difficult for the signal to get detected at the receiver end. There are plenty of techniques introduced to avoid the difficulty in sensing the signal at receiver in M.I.M.O systems. In this paper we will be discussing about the signal detection technique called minimum mean square error technique (MMSE) which uses the inversion of the matrix to retrieve the signal and the iteration-based method that is an improvised technique than MMSE technique where the matrix inversion step is avoided and provides better results. The results are obtained by plotting the bit error rate versus the signal to noise ratio using MATLAB

**Keywords:** Iteration method, MATLAB, MIMO, MMSE.

## I. INTRODUCTION

A variety of different methods are used to make radio-communications very strong, even if there are different channels which include time variations (different times and channel encoding methods), and frequency differences (different channels, wide distribution, and OFDM), location variations. Location variations require the utility of multiple antennas at the transmitter side or at end of the receiver. Many antenna systems are commonly called Multiple Input, Multiple Output systems (MIMO). Many antenna technologies might help to increase the data rate through spatial transmission instead of taming durability. In practice, these two methods are used distinctly or in combination, based on the channel standings. MIMO technology attracts multipath performance using multiple transmitters, and smart-receivers without additional bandwidth to maximize performance and scope. MIMO allows multiple horns to send and receive multiple local streams at the same time. MIMO makes the horns work smarter by enabling them to integrate the streaming of data from different channels and at different times to effectively increase signal capture capabilities. The smart antennas use a variety of spatial technology, which sets out the optimal use of antennas. If there are more antennas than local streams, additional antennas can upsurge the diversity of the receiving system and increase the bandwidth. The detection of the M.I.M.O signal is the process of retrieving the original transmitted signal from the signal that is received.

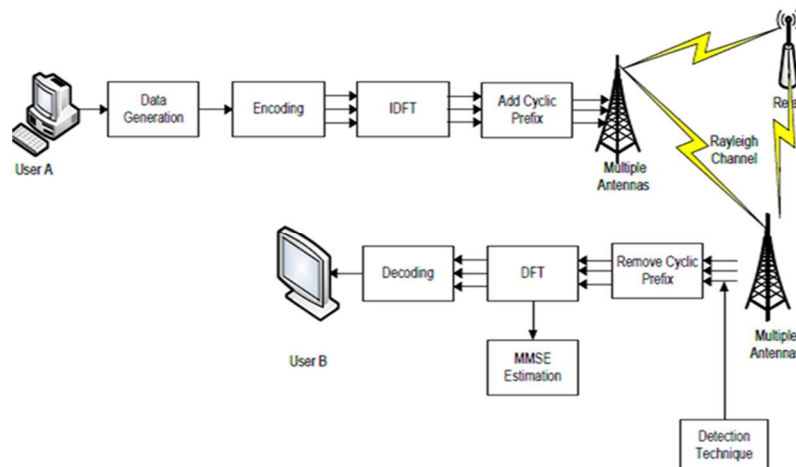

Fig.1: Block diagram of M.I.M.O system

The data we generated will first gets encoded and then converted to inverse discrete form. Later, cyclic prefix id added to the signal before getting transmitted. The original signal  $x$  is transmitted in the form of  $y$  with a multiplication matrix and a bit noise added to it. The transmitted signal is given in the form as:

$$y=H*x + n \tag{1}$$

Where  $y$ = transmitted signal,  $H$ = multiplexed matrix,  $x$  is the original signal,  $n$  is noise added. The process of obtaining the signal  $x$  from  $y$  at the receiver end is called signal detection. After receiving the signal that travelled in wireless medium at the receiving antenna it should first get passed through one of the detection techniques to retrieve the original signal. Then cyclic prefix should be removed it should be converted to discrete form and hence it will be decoded and made available for the user. The detection task is always a tough for M.I.M.O systems so we will go through MMSE technique and iterative method signal detection that outperforms the MMSE technique and analyze their performance with the help of BER vs SNR plots.

## II. LITERATURE SURVEY

Rajvirsinh. C Rana has published his works on “study and analysis of performance of spatial multiplexing equalizer for transmit-receive diversity” [1] in an international journal (ijettcs) helped in understanding the concepts of spatial multiplexing in mimo systems. Zhi Zhang, Meixiang Zhang and Sooyoung Kim proposed “a compact soft MMSE detection scheme for uplink coded massive mimo systems” [2]. They proposed the algorithm of how mmse detection technique can be used to retrieve the signal in mimo systems. It was observed that the mmse detection technique is having higher complexity as it has to perform the matrix inversion at the receiver end. In order to decrease the complexity of signal detector we are proposing an iterative method that has higher performance than mmse detection technique.

## III. MINIMUM MEAN SQUARE ERROR DETECTION TECHNIQUE

The MMSE detection technique is one of the linear detection techniques that are available to retrieve the signal after receiving at the receiver antenna. This technique inverses the gain matrix in the received signal to estimate the original signal.

### A. Working

Consider the equation 1 as the transmitted signal vector with  $x$  as the original signal vector and  $n$  as the white gaussian noise and  $H$  is covariance matrix. Now as we receive the signal as in equation 1 then we need to estimate the vector  $x$  from the vector  $y$ . MMSE method uses a formula that will remove the  $H$  matrix to obtain the estimated vector  $\hat{x}$ .

$$\hat{x} = \text{inv} (Hh*H + (\sigma Z) ^2*I_k) *Hh *y \tag{2}$$

In the equation 2 the  $\hat{x}$  is the estimated signal. And it is obtained with the matrix inversion of signal  $y$ . In equation 2  $Hh$  is the Hermitian of  $H$  matrix,  $\sigma Z$  is the noise variance and  $I_k$  is the identity matrix. The combination of the equation 1 and 2 would result in minimum of the mean of the square of the error. The error values of each antenna and its signal to noise ratio per each receiving antenna will be plotted to analyze the performance of the MMSE detection technique. The value of noise if gets bigger, the MMSE technique would become the matched filter technique and as the noise value gets smaller the MMSE technique would become the zero-forcing detector. The complexity order of the MMSE detection technique is of the order  $O(l^3)$  where  $l$  is the number of receiving antennas. The complexity is high due to the matrix inversion process.

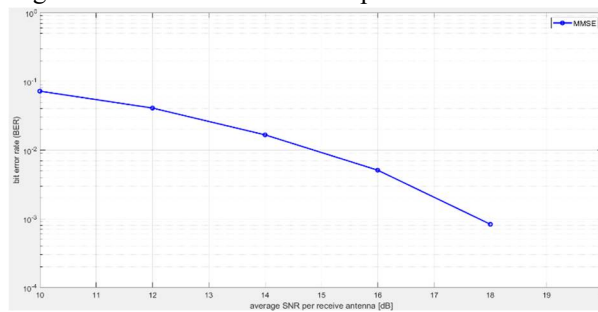

Fig.2 MMSE technique BER vs SNR plot

The BER vs SNR plot of the MMSE detection technique is shown in the fig 2. At the BER value of 0.1, the average snr value per antenna is 10 decibels. And when the value of BER is 0.001 the average snr value per antenna is 18 decibels.

It is clear that as the bit error rate value gets decreased the average snr value per antenna is increasing.

#### IV. PROPOSED METHOD

##### A. Iterative Based Mmse Detection

The major drawback in the MMSE detection technique is found to be its complexity. The inversion of the h matrix that is required to get the signal back in the MMSE technique makes the complexity higher in the order of  $O(k^3)$ . In order to lessen the complexity and remove this drawback in the MMSE technique we proposed a method that would lessen the complexity and provides the results with improved snr value.

Working:

First, we need to decompose the original H matrix in to the diagonal ( $D_i$ ) of h, the upper triangular ( $U_t$ ) part of matrix and then the lower triangular ( $L_t$ ) part of the matrix.

$$H = D_i + L_t + U_t \quad (3)$$

The equation 3 shows the parts in to which the h matrix has to be split. Then we need to initialize the estimation, based on the iterative method to zero as we don't know the initial information. Later we have to estimate the signal based on the iteration method.

$$X_{es}(n) = \text{inv}(D_i + L_t) (y_{mf} - U_t * X_{es}(n-1)) \quad (4)$$

The equation 4 will help in estimating the signal based on iteration method. Where n is the number of current iterations, ymf is matched filter and xes is the signal estimated.

After completing the iteration limit then the signal is detected, now we need to find out how exactly the signal is detected and this can be done based on the bit error rate analysis versus the snr plots.

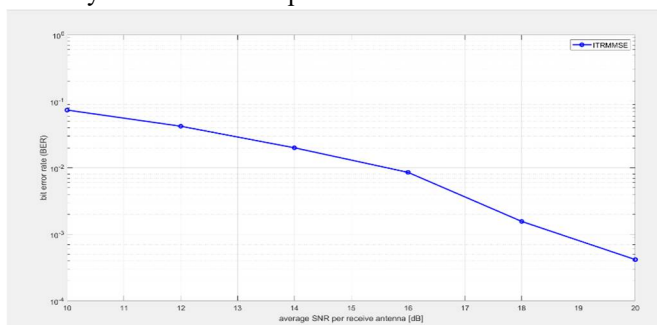

Fig.3 Iterative based MMSE BER Vs SNR plot

The figure 3 shows the plot of BER vs SNR for the iterative based MMSE detection of the signal.

At the BER value of 0.08 the snr value is 10 decibels and when the BER value is  $10^{-3}$  the snr value is 18.5 decibels.

It is clear that as the BER value gets decreased the snr value increasing.

##### B. Comparison Of MMSE And Iterative MMSE

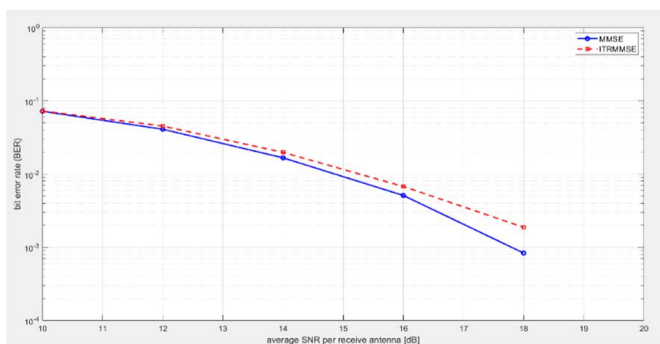

Fig.4. comparison of MMSE and iterative MMSE detection

The fig 4 shows the plots obtained for the MMSE detection technique and the iterative based MMSE detection technique at the fourth iteration which is plotted with the BER vs snr. It is observed that for every value of BER the snr value of the iterative based MMSE technique is high than that of the MMSE technique.

The complexity of the iterative based technique has an order of  $O(k^2)$  where k is number of transmitting antennas. The performance in reducing the complexity and the removal of noise is better in proposed method than that of the MMSE.

## V. FUTURESCOPE

In this paper, many challenges with the MIMO receiver systems were investigated and acceptable solutions for signal detection was offered. It is a well-known fact that the research is a never-ending process as the fresh beginnings occurs. As a result the signal detection requires a lot of focus in establishing a good system performance. The proposed technique can be used in MIMO systems. These techniques can be useful in implementation of 5g technologies.

## VI. CONCLUSIONS

When it comes to MIMO systems, the detection of signal is quite a difficult task. In this paper we have seen that the MMSE detection technique which was one of the frontline detection technique has a high complexity. The complexity is high due to the presence of the matrix inversion step at the receiver end. In the proposed technique we have reduced the complexity as we split the entire matrix and then performed the inversion which made the We have seen how our proposed technique could reduce the complexity and reduce the noise in detecting the signal.

## VII. ACKNOWLEDGEMENT

The author would like to thank the guide for our project Dr S.P.V Subba Rao for being available all the time and guiding us through our project and our coordinator Dr. Shruthi Bhargava Choube for being helpful and making this project successful one.

## REFERENCES

- [1] H. Taub, D. L. Schilling, G. Saha "Taub's Principles of Communication": Tata McGraw Hill, 2008.
- [2] T.S. Rappaport, "Wireless Communication: Principles and Practice": 2<sup>nd</sup> edition, Prentice Hall, 2002.
- [3] S. H. Han, J. H. Lee, "Overview of Peak – to- average Power reduction in Multicarrier Transmission strategies", IEEE Transaction on wireless Communications, April 2005.
- [4] S. Y. L. Goff, B. K. Khoo, C. C. Tsimenidis, B. S. Sharif, "selected Novel Map PAPR reduction technology in OFDM systems", IEEE Communications, vol. 56, No. 11, November 2008.
- [5] Ahmed, Bannour, and Mohammad Abdul Matin. Encoding MIMO-OFDM in Future Wireless plans. Springer international publishing, 2015.
- [6] Dick, Chris and Fred Harris. "OFPM FPGA Implementation in conference record of the Thirty seventh Asilomar Conference, 2004.
- [7] Han, Seung Hee and Jae Hong Lee. "Summary of PAPR rate in multicarrier transmission", Wireless Communications, IEEE 2005
- [8] C. Singh and A. Singh, "Using clipping and filtering to reduce PAPR", International Journal of Advanced Computer Research Science and software engineering and Instrumentation, Vol. 3, 2014.
- [9] Y. A. Jawahar et al., "A Review of Partial Transmit Sequence for PAPR Reduction in the OFDM systems," in IEEE Access, vol. 7. 2019.
- [10] Richard van Nee, Ramjee Prasad. OFDM for wireless communications, 2000.
- [11] Kavitha Mhatre, Uday Pandit Khot. "Efficient selective Mapping PAPR Reduction Technique", in Science Direct, 2015
- [12] T. Datta, N. A. Kumar, A. Chockalingam and B. S. Rajan, " A novel MCMC algorithm for near optimal detection in large scale uplink multiuser MIMO systems," in proc. Inf. Theory Appl, Feb, 2012, pp, 69-77.
- [13] W. C. Sun, W. H. Wu, C. H. Yang, and Y. L. Ueng, " An iterative detection and decoding receiver for LDPC -coded MIMO systems," IEEE Trans Circuits Syst. I, vol.62.



10.22214/IJRASET



45.98



IMPACT FACTOR:  
7.129



IMPACT FACTOR:  
7.429



# INTERNATIONAL JOURNAL FOR RESEARCH

IN APPLIED SCIENCE & ENGINEERING TECHNOLOGY

Call : 08813907089  (24\*7 Support on Whatsapp)