



# IJRASET

International Journal For Research in  
Applied Science and Engineering Technology



---

# INTERNATIONAL JOURNAL FOR RESEARCH

IN APPLIED SCIENCE & ENGINEERING TECHNOLOGY

---

**Volume: 9      Issue: VI      Month of publication: June 2021**

**DOI: <https://doi.org/10.22214/ijraset.2021.36062>**

**[www.ijraset.com](http://www.ijraset.com)**

**Call:  08813907089**

**E-mail ID: [ijraset@gmail.com](mailto:ijraset@gmail.com)**

# Design of Inbuilt Automatic Pneumatic Jack for Four Wheelers

Chandrashekhar Sakhale<sup>1</sup>, Sagar Sakharwade<sup>2</sup>, Kshitij Wahane<sup>3</sup>, Rahul Thuse<sup>4</sup>, Rushikesh Kolgotwar<sup>5</sup>, Khemraj Bhojar<sup>6</sup>, Rutvik Atkarne<sup>7</sup>

<sup>1</sup>Assistant Professor, <sup>2,3,4,5,6,7</sup>Under Graduate Scholars

Department of Mechanical Engineering, Priyadarshini College of Engineering, Nagpur, India

**Abstract** — This project deals with design and manufacturing of automatic pneumatic jack, which can lift the light weight vehicles and will be use full to maintain and inspect the vehicle's vital components connected to downside. This jack would be permanently mounted on the chassis on the vehicle and will be automatically operated which will eliminate manually operating it to raise the vehicle and would save valuable time. The most important thing about this research is that it does not require any external power supply for its functioning and it consists of the pneumatic system and hence does not require the storage of air as it is easily available unlike the hydraulic system where the oil tank is required to store the oil. The objective of the project is to develop an automatic pneumatic lifter which automatically lifts the vehicle.

**Keywords**— Pneumatic Jack, jackscrew, hydraulic jack, pneumatic cylinder, rack and pinion, automation.

## I. INTRODUCTION

Due to the matter of operating automobile jacks, various kinds of electric jacks are proffered. With the event of such electric jacks has gradually come an understanding of variety of the problems associated therewith. thanks to the torque needed to lift something as heavy as most automobiles, direct drive electric motors aren't reliable; therefore, gearing drive mechanisms of some sort should be used , as a severe ratio must be utilized. Direct motor-to-jack drive, with only two gears, fails to accomplish this task. Electric jacks that are built into an automobile haven't been accepted because of expense and thus the need to a minimum of lift all sides of an auto, if not all corners individually. If a system is chosen to individually lift each corner of the auto, even greater expense in design, production, and price is encountered. Some have even entertained total encasement of a jackscrew type device. The invention relates to hydraulic jack and more specifically to an automobile hydraulic jack system. In most of the garages the vehicles are lifted by using jackscrew . This needs high man power and skilled labors within the past both hydraulic and pneumatic jack has been utilized together with the structure of automobile. they need always utilized a separate jack for every of 4 wheels by having the jacks permanently installed on the vehicle.

They are able to operation in the least time. device has been installed on vehicle, like air device . Various sorts of jack or lift devices has been installed on vehicle which are turned in 1 fashion or another from a horizontal altitude into a vertical altitude then extended for the aim of lifting the vehicle. Thus automatic pneumatic jack is one solution for all this problems. Pneumatic cylinder is employed during this concept. Selection of pneumatic jack is predicated on weight of auto . Manual operated direction control valve is employed to actuate cylinder. it's believed that "Necessity is that the mother of invention". Here the necessity lies in reducing the human effort applied during manual operation of the jacks and hence the need of the invention. In day to day life it's extremely tedious job to figure the jack manually and it is also a very time consuming work also . to scale back the human effort for operating any quite jack separately. this may most appropriately benefit senior citizens to supply a secure and straightforward automatic pneumatic jacking system without manual effort. to supply a totally unique jacking system which can be operated from within the vehicle by means of a dashboard control panel . There are certain mechanisms already available for the same purpose which features a particular capacity to lift the car on 2 wheels viz. a jackscrew , hydraulic jack etc. But the general idea of the project is to attenuate the human effort while operating the jack. to supply a completely unique pneumatic jacking system that's directly and permanently incorporated into the vehicle frame such how on prevent the extra risk of injury or wear and tear.

## II. LITERATURE STUDY

A. C. JAGADEESH et. al. Studied that Style and Fabrication of a Vehicle with Inbuilt Automatic Pneumatic Jack

There are many safety hazards posed with manually raising a vehicle to vary a tire. Standard car jacks pose an excellent safety hazard thanks to the physical and time consuming involvement of the operator. Aftermarket automatic hydraulic jacks though safer still are hazardous as they need to be manually placed under the vehicle and have limited use. A pneumatic car jack that's permanently attached to the under body of a vehicle will reduce and eliminate many of those questions of safety . The pneumatic jack was designed based on the relative weights of the customer requirements that are given the foremost importance and therefore the engineering features with the very best relative importance so as to ensure that customer needs are met. This

ensured that the car jack was designed with the customer's needs in view and thus proved to be a successful product. Thus, by given above construction and dealing, the research work is completed successfully.

The design is completed on Catia software. Hence this research work beats hydraulic jack and improves its efficiency. This reduces human effort. The air is required for pneumatics and it's available enormous level in atmosphere. to regulate the system, only ON and OFF are used and therefore the system consists only of ordinary cylinders and other components, making it simpler than hydraulics. As our jack is inbuilt the work fatigue is a smaller amount also as cost is additionally less.

*B. S. SATHIYARAJ et. al. Studied that Style and fabrication of pneumatic jack for automation*

The main target of project is to enhance version of a mini pneumatic jack. this may be more efficient for the user. This machine is pneumatic powered which has low coefficient of friction. A pneumatic cylinder erected provides power to lift up the Jacky. This is a pneumatic powered machine and requires no other means of power to work . The required components are Compressor, Pneumatic cylinder, Solenoid, Control circuit and Jack.

The project administered by us made an impressing task within the field of automobile and automobile workshops. it's very usefully for the workers to figure in the automobile workshop are within the station . This project has also reduced the cost involved within the concern. Project has been designed to perform the whole requirement task which has also been provided.

*C. MANJESH B C et.al. studied that the problem in lifting any passenger and light moving vehicle sort of light vehicle*

The survey within the regard in several automobile garages, revealed the facts that some difficult methods involving physical efforts were adopted in lifting the vehicles for reconditioning. The project is especially targeting this difficulty; hence an appropriate arrangement has been designed by the mixture of two main stages. compressed gas production using vehicles suspensor: during this project, the atmospheric air is sucked using our experimental setup and obtain compressed by non-conventional method just by driving vehicle air is stored within the tank .

Automatic pneumatic jack for four wheelers: by utilizing the compressed gas , the pneumatic jack which is mounted on the chassis are often operated so as to lift the vehicle for the aim of adjusting tyre or for wheel alignment etc. They have combined the inbuilt jack with applications of the compressed gas production using vehicle suspensor. The compressed gas production using vehicle suspensor get its energy requirements from the mobility of the vehicle, there's no need of counting on external source for air compression.

The Inbuilt automatic pneumatic jack are often operated using the compressed gas so as to lift the vehicle for changing of tires, wheel alignment, under chassis repair work etc. This project is an experimental setup during which there's no engine or gearbox assembly to run and compress the air but the methodology utilized in our work are often implemented which is practically possible. Thus, the event of an Inbuilt Automatic Pneumatic Jack for passenger vehicle or any LMV's may be a low cost automation. The procedure of this technique is extremely simple, so a person can operate. By using more techniques. They can be modified and developed consistent with the applications. As they know that jack is inbuilt this has less chances of fatigue.

*D. P.S.BORKAR et.al. studied that the fabrication is predicated on pneumatic which deals with the study and application of pressurized air to supply mechanical motion. Pneumatic jack may be a fabricated model which when installed in four wheeler, will ease within the problem arising within the conventional operated jack*

After completing the project they need come to the conclusion that pneumatics jacks can act within the place of hydraulic jacks efficiently. The inbuilt jack is the boon for the cars. The air required for the operating of the jack is definitely available within the nature. Cost of the project isn't high compared with other jacks. As their jack is inbuilt the fatigue is a smaller amount . If made within the lot the value might be less. It serves better than hydraulic jacks which is employed for lifting up. Pneumatics working fluid is additionally widely available and most factories are pre-plumbed for compressed gas distribution, hence pneumatic equipment is simpler to set-up then hydraulics. For opening and shutting of underwater valves, pneumatic systems work well because they will sustain overload pressure conditions.

*E. VIVEK.J.V et.al. studied that to increase the productivity, the skilled labours were going for automation. To overcome this stage they have selected project work is to acquire practical knowledge in the field of mechanism using jack*

They selected pneumatic lifting jack, as their project work and they used this process in all machine attachment like drilling, milling jig boring and surface grinding. The material handling mechanism is achieved by movable of handle in this jack. When the compressed air is passed through the pneumatic cylinder the piston will move. At the end of the piston connected to the moving rod. The moving rod is move to forward and backward stroke will obtained. The fixed rod to fixed in the base table. Now the piston movement to lift the load. The fabrication of the model lifting jack with pneumatic arrangement has completed successfully and efficiently and it is count to be good. The initial cost of the cost is moderate to other costly pneumatic jacks used in various expensive cars. The objective of the project was to design a quick lifting pneumatic jack which was more efficient than the conventional screw jack used in light weight vehicles in productions today.

### III. OBJECTIVE OF PROJECT

The specific objectives of the study can be summarised as follows.

- A. To design and develop efficient jack system.
- B. To minimize manual affords.

### IV. WORKING

When there is a need to lift the vehicle for any reason like, to remove the puncture, to inspect the inner important components the driver need to press a button. This button actuates the air compressor fitted in the system. The air compressor sends the compressed air to the pneumatically operated cylinder.

This cylinder then acts as the actuator and lifts the vehicle. After the objective, working of driver got complete, he needs to press the button again. The pneumatic circuit is made in such manner so that after pressing the button vehicle comes to its original position. The basic layout of a pneumatic system is shown in fig. It might be observed that the essential components involved are almost like a mechanism .

#### A. Working of Pneumatic Cylinder

Basic principle of Pneumatic System

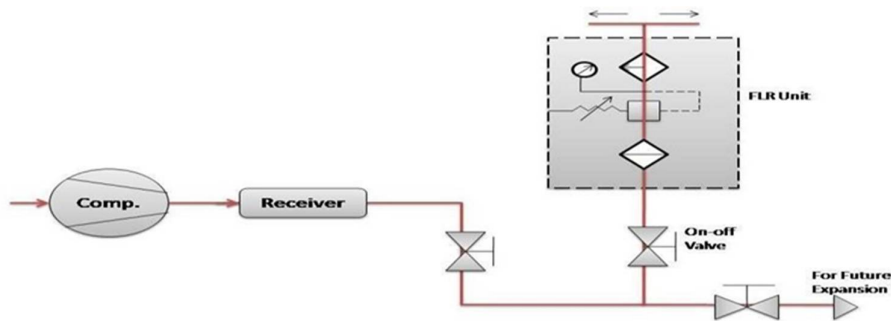

Fig 1 Basic pneumatic system

The basic differences between hydraulic and pneumatic systems are that in mechanism the input energy is imparted to the oil is by pump, whereas, in pneumatic systems the working fluid being air, the energy is imparted to air by a compressor. Further, a mechanism usually operates at very high pressures to transmit the massive force and power while a pneumatic system operates at low pressures of about 5 – 7 bar for industrial applications. The major components of the pneumatic systems are:

- A compressor of appropriate capacity to satisfy the compressed gas requirements.
- A receiver to store the compressed gas.
- Air distribution lines to distribute the air to varied components of the system.
- Filter lubricator regulator (FLR) unit for conditioning of air and regulation of pressure.
- Pneumatic control valves to manage, control & monitor the air energy.

### V. CAD DESINGS

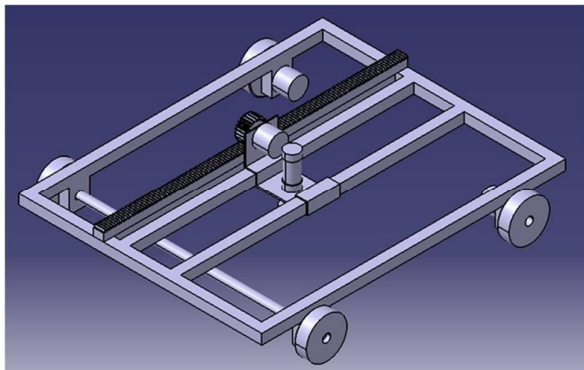

Figure 2: Automatic pneumatic jack

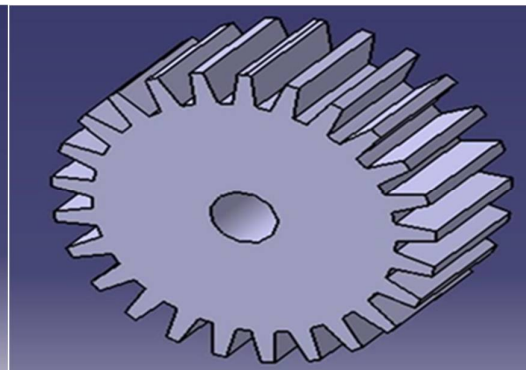

Fig 3: Pinion

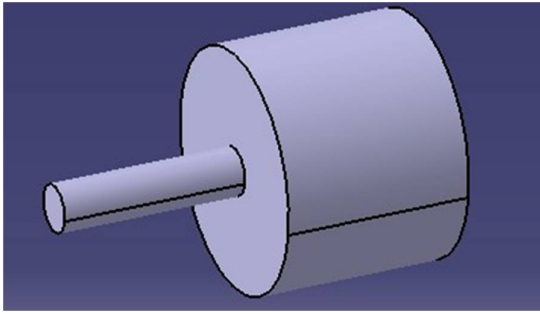

Fig 4 Motor used to move the system

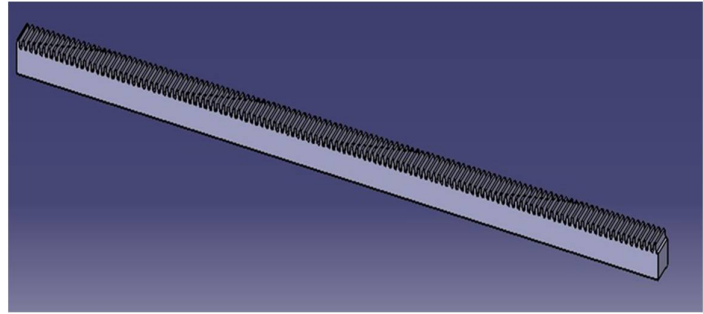

Fig 5 Rack

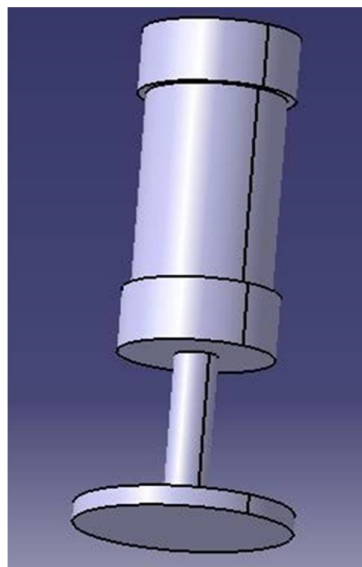

Fig 6 Pneumatic cylinder

## VI. RESULTS AND DISCUSSION

### A. Result

- 1) We can lift the weight of 25 kg at 327 KPa.
- 2) Pneumatics working fluid is also widely available and most factories are pre-plumbed for compressed air distribution, hence pneumatic equipment is easier to set-up than hydraulics.
- 3) To control the system, only ON and OFF toggle switch are used and the system consists only of standard cylinders and other components, making it simpler than hydraulics.
- 4) The working fluid of the pneumatic system absorbs excessive force, leading to less frequent damage to equipment.
- 5) In case of excess pressure built-in, a pressure relief valve can be installed to release the excessive pressure when it crosses the required pressure limit.

### B. Advantages

- 1) The loaded light vehicle can be easily checked and cleaned, as the main parts are screwed.
- 2) Main parts are screwed.
- 3) No manual power required.
- 4) Easy to repair.
- 5) Replacement of parts is easy.
- 6) Handling is easy.
- 7) Maximum height up to 1.5 feet can be reached.



### C. Possible Outcomes

- 1) From the evolution of Vehicles, the common problem when tire goes flat is changing of tires by lifting the vehicle using Jack and lever and it's a tedious job for any person in that case.
- 2) Generally to operate it a person must bent down to squatting position which may lead a back pain. Especially for Senior citizens, female drivers and physically challenged drivers it is an impossible task. The work input on the jack completely depends on the weight of the vehicle that is to be lifted. In this project an inbuilt automatic pneumatic jack is built and placed in the vehicle.
- 3) Now a day we are using automated hydraulic jack which consists of spring, compressor, pressure gauge, storage, single acting cylinder etc. This automated jack doesn't require any kind of human effort and can be operated by anyone like children, women, and old people. It does not make a person to bend or to be in squat position to operate.

## VII. CONCLUSION AND FUTURE SCOPE

### A. Conclusions

- 1) The Inbuilt automatic pneumatic jack are often operated using the compressed gas so as to lift the vehicle for changing of tires, wheel alignment, under chassis repair work etc.
- 2) Our project is an experimental setup in which there is rack and pinion assembly due to which the jack can move in forward and backward direction as per the requirement.
- 3) Thus, the event of an Inbuilt Automatic Pneumatic Jack for passenger vehicle or any LMV's may be a low cost automation. The procedure of this system is very simple, so any person can operate. By using more techniques, they can be modified according to the applications. As we know that our jack is inbuilt this has less chances of fatigue.
- 4) Less human efforts are required.

### B. Future Scope

This innovation would help the ladies elders and other fellow folks to simply change the tires when stuck within the middle of nowhere. This innovation would save time of putting in a manual jack and unloading the vehicle because the problem of unloading would be minimized. It would help in washing of the lower body of the car because it would raise the car by about 2 feet. It would help the mechanic to repair on road because the innovation would increase the road clearance of the car and would be easily repaired.

Since a jack has always been an integral a part of any operation related to servicing of the vehicle therefore with some substantial modifications like, by increasing the specified torque and power capacity of the jack it are often used also for LMVs. Some modifications can also be implemented into the designing of the vehicle chassis to accommodate the jack. This will not only be an efficient design but also be rugged.

## REFERENCES

- [1] Sreevalsan S Menon, Sooraj M S, Sanjay Mohan, Rino Disney, Suneeth Sukumaran "Design and Analysis of KERS in Bicycles", International Journal of Innovative Research in Science, Engineering & Technology, Vol. 2, Issue 8, 2013.
- [2] Ricardo Chicurel, "A Compromise Solution for Energy Recovery in Vehicle Braking," Energy, vol.24, 2009.
- [3] Medicott P.A.C., "Development of A Light Weight Low Cost Flywheel Energy Storage System for A Regenerative Braking Application," The British Petroleum Company Plc. 20th Inter Society Energy Conversion Engineering Conference (IECEC), Miami Beach, Florida, 1985.
- [4] Radhika Kapoor, C. Malik Parveen, "Comparative Study on Various KERS", Proceedings on the World Congress on Engineering, Vol. 3, 2013.
- [5] JackK.Sainath, Mohd Salahuddin "Design of Mechanical Hydraulic", International Journal of Innovative Research in Science, Engineering & Technology, Vol. 2, Issue 8, 2002.
- [6] Rajmohan G, Jazim Harris: "Inbuilt Lifting Arrangements for Heavy Vehicles Braking," Energy, vol.24, 2004. Vigneswari: "Compressed Air Production Using Vehicle Suspension", "Comparative Study on Various KERS", Proceedings on the World Congress on Engineering, Vol. 3, 2005.
- [7] Sourabh Savadatti, Amit Doddamani: "Android Controlled Automatic Jack System for Vehicle" fluid mechanism and hydraulic Machines, R. K. Bansal, Laxmi Publications Pvt., Ltd, 22, Golden House, Daryaganj, New Delhi – 110 002
- [8] Farhad Razzaghi (2007) "Automated Car Jack", International Journal of Current Engineering and Technology (Vol.4, No.4, Aug 2014) E-ISSN 2277 – 4106, P-ISSN 2347 – 5161.
- [9] Thomas J. Prather (2009) "Automated Car Jack", International Journal of Current Engineering and Technology Vol.4, No.4, Aug 2014) E-ISSN 2277 – 4106, P-ISSN 2347 – 5161.
- [10] Lokhande Tarachand G., Chatpalliwar Ashwin S. And Bhojar Amar A., "Optimizing Efficiency of Square Threaded Mechanical Screw Jack by Varying Helix Angle", International Journal of Modern Engineering
- [11] Research (IJMER) (Vol.2, Issue.1, Jan-Feb 2012 pp- a 504-508) ISSN: 2249-6645



10.22214/IJRASET



45.98



IMPACT FACTOR:  
7.129



IMPACT FACTOR:  
7.429



# INTERNATIONAL JOURNAL FOR RESEARCH

IN APPLIED SCIENCE & ENGINEERING TECHNOLOGY

Call : 08813907089  (24\*7 Support on Whatsapp)