



IJRASET

International Journal For Research in
Applied Science and Engineering Technology



INTERNATIONAL JOURNAL FOR RESEARCH

IN APPLIED SCIENCE & ENGINEERING TECHNOLOGY

Volume: 9 Issue: VI Month of publication: June 2021

DOI: <https://doi.org/10.22214/ijraset.2021.36138>

www.ijraset.com

Call:  08813907089

E-mail ID: ijraset@gmail.com

A New Type of Solar Energy Measurement System using PIC Controller

Anjali Kumari¹, Debabnjana Das², Debarati Roy³, Mahuya Maity⁴, Plaban Mal⁵, Koushik Pal⁶, Samiran Chatterjee⁷

^{1, 2, 3, 4, 5, 6} Department Of Electronics and Communication Engineering ,Guru Nanak Institute Of Technology

⁷Department Of Electronic And Communication, Vignans Institute Of Management And Technology For Women, Hyderabad

Abstract: As we know solar energy is an very important aspect in respect to the present environmental situation. It is necessary to change our energy resources from non renewable to renewable sources. This project is designed to measure energy of solar panels. The current and voltage are measured so that we can monitor these parameters and get to know where to use them and what updations should be made to increase there productivity, efficiency with low maintenance. Here, the measurements are done by the help of different sensors and PIC microcontroller.

Keywords: Solar Energy, Renewable sources, PIC microcontroller

I. INTRODUCTION

In this project we will discuss about the solar energy measurement using pic microcontroller. As we know the solar energy market place is one of the most quickly growing renewable energy advertise in the whole world as now a days it is very important to use renewable energy to preserve the world from destruction. It is a major goal of todays economies to switch to sustainable resources so that the technology can grow in its pace without harming the planet. Due to which it is necessary to choose the correct place where the solar plants can be installed so that we can harvest the maximum of the energy and put it to good use. The more we will use solar energy the less our environment will be harmed. Whether we need sites pattern of solar power generation or monitoring act of accessible solar installations or superior solar monitoring .The precise measurement of voltage and current are very crucial as they can help the designing and making more developed product which will require less maintenance and will be much more efficient. In this project we are using Pic microcontroller specifically pic16f877a. Which is a very high performance microcontroller. And current and voltage sensors to take the measurements.[1]

II. OBJECTIVE

The main purpose of this solar energy measurement system project is to design a solar energy measurement system for determining the solar cell parameters like current, voltage, temperature and also light intensity through multiple sensors

The solar energy marketplace is one of the most quickly growing renewable energy advertise in the United States. Currently, we have seen an important enhancement in requirements for remote monitoring and equipment control for different applications of solar energy. Whether you are assessed a sites potential for solar power generation, monitoring act of accessible solar installations, or superior solar monitoring, consistent and precise measurements are crucial. They help in decision making, development of the product, maintenance of the system and in many other ways. General meteorological measurements with wind direction, wind speed, relative humidity, barometric pressure and rainfall, all have theyre applied in solar applications. Of course, the solar energy measurements are particularly significant and sensors are accessible for measuring all features of solar radiation[2][3].

III. METHODOLOGY

In the block diagram we can see voltage sensor and current sensor are used. These devices mainly measure the voltage and current flowing to load from solar panels as the solar panels are power sources. Liquid crystal is also used for displaying the value of current and voltage and the power of solar panels. Here 5 volt DC power is used. It provides operating voltages to microcontroller and liquid crystal display.In circuit diagram we can see that a voltage driver is used. It drives voltage lower than 5 volt as microcontroller cannot read voltage more than 5 volt. So voltage driver is used to lower voltage more than 5 volt. Then a polar and non polar capacitors are used. These remove harmonics and provide constant voltage to ADC pin of microcontroller. Here polar capacitor is used to avoid voltage fluctuations and non polar capacitor is used here to remove harmonics. LM35 temperature sensor can be used too. It is calibrated in Celsius over Kelvin as in Kelvin calibrated sensor there is a requirement. It subtracts a constant voltage from its output. With the single power supply LM35 temperature sensor can also be used. -55 to +150 is the temperature range in between which the device can be used.[4][5]

IV. GENERAL DESCRIPTION OF THE COMPONENTS

- 1) *PIC microcontroller (16f877a)*: The PIC microcontroller PIC16f877a is one of the most renowned microcontrollers in the industry. This microcontroller is very convenient to use, the coding or programming of this controller is also easier. One of the main advantages is that it can be write-erase as many times as possible because it uses FLASH memory technology. It has a total number of 40 pins and there are 33 pins for input and output. PIC16F877A is used in many pic microcontroller projects. PIC16F877A also have much application in digital electronics circuits. An EEPROM is also featured in it which makes it possible to store some of the information permanently like transmitter codes and receiver frequencies and some other related data. The cost of this controller is low and its handling is also easy. It has a smaller 35 instructions set. It can operate up to 20MHz frequency. The operating voltage is between 4.2 volts to 5.5 volts. If you provide it voltage more than 5.5 volts, it may get damaged permanently. It does not have an internal oscillator like other PIC18F46K22, PIC18F4550. The maximum current each PORT can sink or source is around 100mA. Therefore, the current limit for each GPIO pin of PIC16F877A is 10 milliamperere. It is available in four IC packaging such as 40-pin PDIP 44-pin PLCC, 44-pin TQFP, 44-pin QFN
- 2) *Solar Panel*: Expose the cell to light, and the energy from each photon (light particle) hitting the silicon, will liberate an electron and a corresponding hole. If this happens within range of the electric fields influence, the electrons will be sent to the N side and the holes to the P-one, resulting in yet further disruption of electrical neutrality. This flow of electrons is current; the electrical field in the cell causes a voltage and the product of these two is power.
- 3) *LDR*: A photo-resistor or light dependent resistor (LDR) is a resistor whose resistance decreases with increasing incident light intensity. It can also be referred to as a photoconductor. A photo-resistor is made of a high resistance semiconductor. If light falling on the device is of high enough frequency, photons absorbed by the semiconductor give bound electrons enough energy to jump into the conduction band.[7]

V. BLOCK DIAGRAM

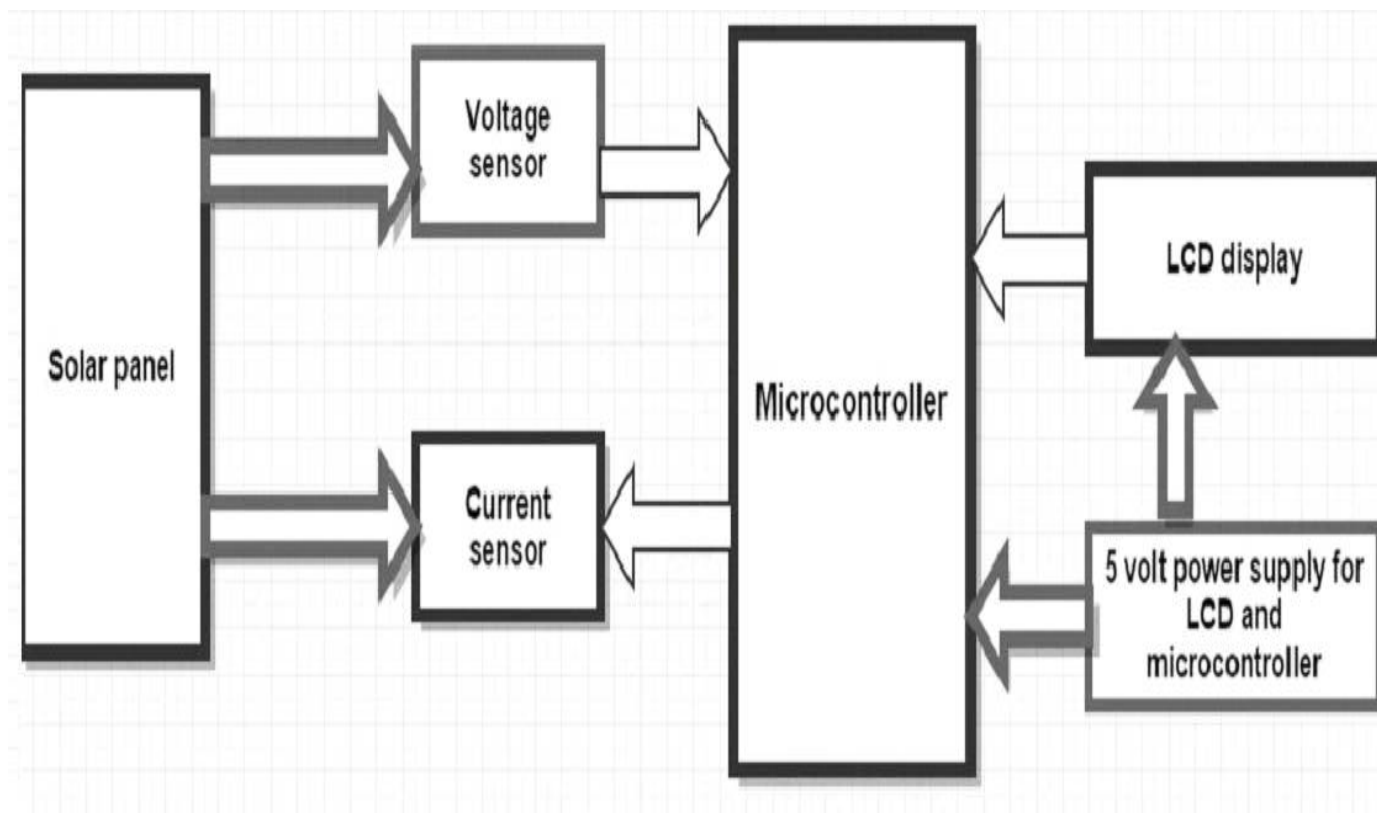

VI. FLOWCHART

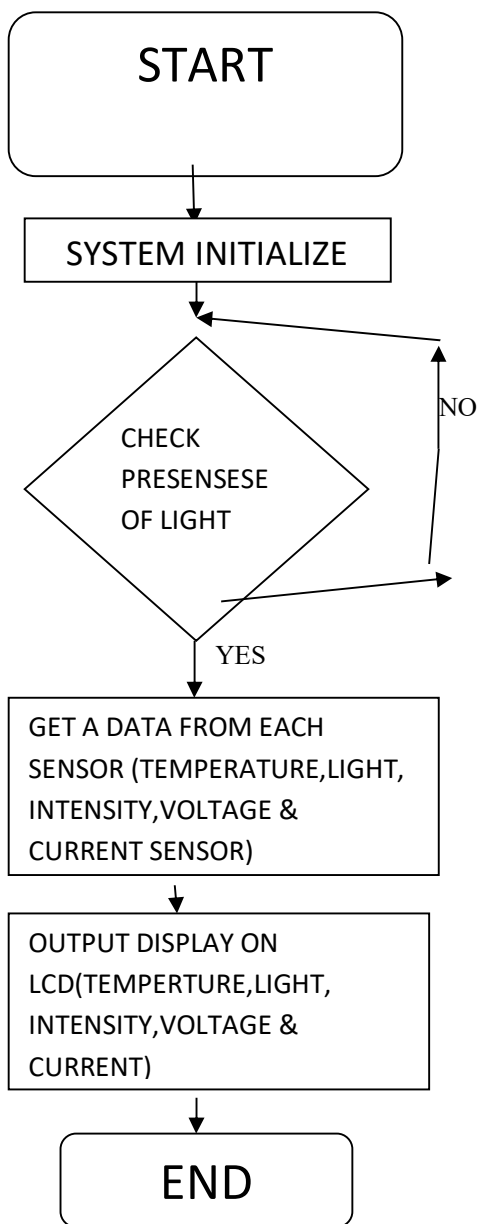

VII. WORKING OF THE SYSTEM

To better understand the working of the project we can divide the whole working into three parts.

First part is about measuring the voltage using PIC microcontroller. The voltage divider is used to divide voltage to lower than 5 volt. Input to circuit is 220 volt AC voltage. Potential transformer step downs 220 volt AC voltage in 12 volt AC. After that bridge rectifier converts step down AC into pulsating dc voltage. Voltage divider further divides the voltage into two parts. Voltage less than 5 volt appear across analog to digital converter pin of pic16f877a microcontroller. Because microcontroller can not read voltage more than 5 volt. Therefore voltage divider is used to lower voltage less than 5 volt. Polar and non polar capacitors are used to remove harmonics and to provide constant voltage to adc pin of microcontroller. Polar capacitor is used to avoid voltage fluctuation and non polar capacitor is used remove harmonics and it will stop harmonics to read to microcontroller which may damage microcontroller. Microcontrollers are basically small micro computers which understand only digital values. Built in analog to digital converter module of pic16f877a microcontroller converts analog values of AC voltage into digital values.

These digital values are used in processing of data with in microcontroller. Pieces of instructions written in the form of coding told microcontroller what to do .Microcontroller itself do not do anything. Now the second part is how to measure alternating current? To better understand this we can divide the whole current measurement part in two parts — one is how to use a current transformer to measure ac current and what is the best way to interface current transformer (CT) with PIC16F877A microcontroller. CT is used to measure an alternating high current of the order of thousand Amperes. It steps down ac current to lower value so that it can be easily read with the help of a microcontroller. The step-down the ability of the current transformer depends on the rating of the current transformer and its current step down ratio. Suppose a current transformer with a current ratio of 100:10 Ampere. Its mean primary current of the transformer is 100 Amp and the secondary current is 10 Amp. We can not use this current transformer to measure current more than 100 Amp. By measuring the secondary side low current, we can easily convert it into primary current value by using the current ratio formula. We cannot measure current directly. Firstly, we convert the secondary side current into voltage. We can use a known value of resistor load. We measure the voltage across this known resistor. After that, we can convert this measured voltage into the current. We can use ohms law formula to convert the voltage into the current. To measure ac current with a PIC microcontroller, we have to use the ADC module of PIC microcontroller. To use the ADC module, we will convert current into voltage form by using a shunt resistor of .05 ohm is used in series to load. Voltage drop across shunt resistor used to measure current. In other words, shunt resistor used as a transducers which is used to convert current into voltage form because microcontroller can not read current directly. Output of shunt resistor is fed to difference amplifier. Difference amplifier is also step up voltage. Because in case of very low current, small voltage will appear across shunt resistor and microcontroller can not read voltage less than its resolution but the problem is ADC of the pic microcontroller can never measure voltage greater than 5 volts. Therefore to solve this problem, we can use the difference amplifiers. Because, by adjusting the gain of the difference amplifier, we can reduce voltage lower than 5 volts. The following diagram shows the circuit of CT and difference amplifier interfacing. We can use any op-amp such as LM741, TL074.Connecting the secondary side of CT to the points shown on the schematic .After that, connecting the shunt resistor in parallel with the current sensor. The difference amplifier circuit converts voltage below 5-volt magnitude. It also shifts the level of ac voltage from the negative side to the positive side. Now connecting output of difference amplifier with RA1 or analog channel one of PIC16F877A. Now the last part is to interface the LCD with the microcontroller. Liquid crystal display is used to display values of current, voltage and power on LCD. It is very easy to interface LCD with pic16f877a microcontroller. It can work in two modes, 4-bit and 8-bit. In this tutorial, we have used the 4-bit mode which uses only 4 data lines, thus saving pins of the microcontroller. So it is recommended to use LCD in four bits mode to save pins of the microcontroller for other applications. A variable resistor is used to adjust the contrast of 5×8 dot pixels according to background light. Therefore, if we are not able to see anything on LCD after programming, the maximum changes are that we need to adjust contrast with the variable resistor. This contrast register makes adjust to the voltage applied on the VEE pin.[6][4][9]

VIII. CIRCUIT DIAGRAM

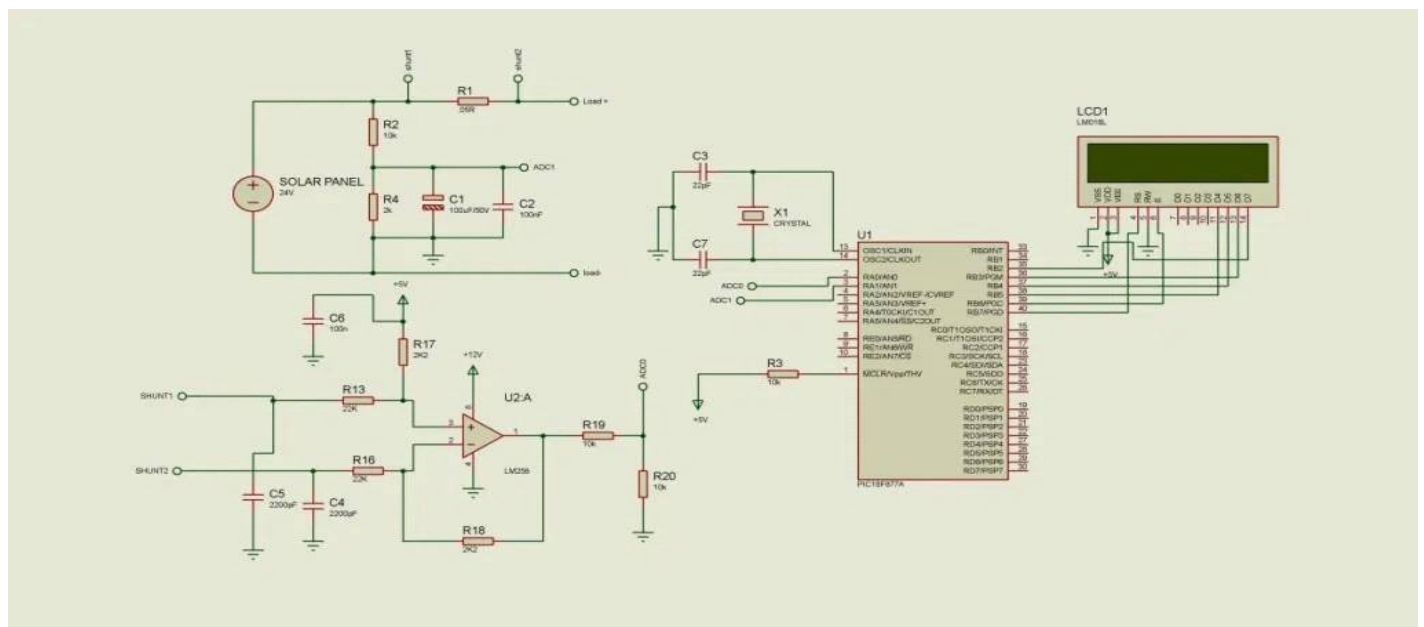

IX. CONCLUSION

In this project we attempted to determine solar cell parameters like voltage, current, power, temperature using PIC16F877A microcontroller. PIC microcontroller can be used to compute simple estimations of these solar cell parameters and easy to computerized to converter which is in worked in PIC microcontroller. There are various approaches to detect voltage. But in this proposed work, we can do so without much of a stretch measure voltage of sun based board utilizing voltage divider. Two capacitors are based parallel to voltage estimation resistor to stay away from voltage variance and dodge sound to go into ADC of PIC microcontroller. In this system we have used differential intensifier to enhance voltage showing over shunt resistor.

X. FUTURE SCOPE

Solar energy is used as an efficient energy source in modern days and generation of solar energy is quickly growing in every country. Solar panels are used to convert solar energy into electricity to power house lighting, appliances etc. The main purpose of this project is to design a system to determine solar cell parameters like current, voltage etc. So this has very good scope in the near future in various industries.

REFERENCES

- [1] "Solar radiation measurement" written by Tom Stoffel & Steve Wilcox at Aug. 20004.
- [2] "How a solar cell converts solar Energy to Electricity" written by Turner, Gillian in 2006.
- [3] microcontrollerslab.com
- [4] N.Femia, G. Petrone, G. Spagnuolo, and M. Vitelli, "Optimization of perturbation observe maximum power point tracking method," IEEE Trans. Power Electron., vol. 20, no. 4, pp. 963—973, Jul. 2005.
- [5] N. Kasa, T. Iida, and L. Chen, "Flyback inverter controlled by sensorless current MPPT for photovoltaic power system," IEEE Trans. Ind. Electron., vol. 52, no. 4, pp. 1145—1152, Aug. 2005.
- [7] Components101.com/microcontrollers/pic16f877a-pin-diagram-description-features-datasheet
- [8] Microcontrollerslab.com/pic16f877a-introduction-features
- [9] www.eia.gov/energyexplained/solar/solar-energy-and-the-environment
- [10] www.ucsusa.org/resources/environmental-impacts-solar-power



10.22214/IJRASET



45.98



IMPACT FACTOR:
7.129



IMPACT FACTOR:
7.429



INTERNATIONAL JOURNAL FOR RESEARCH

IN APPLIED SCIENCE & ENGINEERING TECHNOLOGY

Call : 08813907089  (24*7 Support on Whatsapp)