



IJRASET

International Journal For Research in
Applied Science and Engineering Technology



INTERNATIONAL JOURNAL FOR RESEARCH

IN APPLIED SCIENCE & ENGINEERING TECHNOLOGY

Volume: 9 Issue: VII Month of publication: July 2021

DOI: <https://doi.org/10.22214/ijraset.2021.36151>

www.ijraset.com

Call:  08813907089

E-mail ID: ijraset@gmail.com

Small Size Digital Oscilloscope Using ARM Processor

Ms. Dhanshri Damodar Patil¹, Prof. V. M. Umale²

¹(M.E.Student) Electronics Department, SSGM College of Engineering, Shegaon

²(Asst. Professor), Electronics Department SSGM College of Engineering, Shegaon

Abstract: Oscilloscopes are indispensable tools for anyone designing, manufacturing or repairing electronic equipment. In today's fast-paced world, engineers need the best tools available to solve their measurement challenges quickly and accurately. As the eyes of the engineer, oscilloscopes are the key to meeting today's demanding measurement challenges. There are many types of oscilloscope available in the market. The main types of oscilloscopes are analog oscilloscope, digital oscilloscope and PC based oscilloscope. From which the digital oscilloscope are widely used now a days due there accuracy portability, high speed, high resolution, data storing capability etc. here we provide an alternative solution which is basically a digital oscilloscope with almost all the control options which any standard digital oscilloscope has. This paper describes the development of a portable, very low cost oscilloscope. The user can start/stop the display, adjust the time division and adjust the voltage division. The features of this device make it suitable for implementing as an educational re-source for graduate students from Electrical, Electronics, Instrumentation, and Computer Science faculties.

Keywords: ARM processors, Oscilloscope, GLCD.

I. INTRODUCTION

Oscilloscope is a measuring device which can show various waveforms & voltages, Frequency, time period, wavelength on screen. Graph show the variation of signal amplitude (Y-axis) with time (X- axis). The oscilloscope accepts voltage signals at its input, but virtually any type of signal (vibration, heartbeat, ECG, speed of objects, sound, light ashes, etc.) can be viewed in an oscilloscope with the use of transducers. Today world is moving towards digitization & now days Advanced RISC Machine (ARM) is the most important building blocks in lots of applications. The digital oscilloscopes takes the input signal and convert it into a digital signal, through an analog-to-digital converter (ADC), which is then analyzed and used to plot an image of the original signal on liquid crystal display (LCD) screen. The digital oscilloscope produces every waveform as a sequence of samples. These samples are then saved until it accumulates enough samples to portray a waveform. The advantage of these types of scopes is that a trace can be store and displayed along-side others for comparison or calibration. Digital oscilloscope can allow you to capture and view events that may happen only once transient event. Thus, digital oscilloscopes are widely used all over the world due to its advantages.

The primary parts are microprocessor and display device. ARM microprocessor is used as a controlling element and this will produce output at very fast speed when compared to microcontrollers. ARM consists of in-build ADC thus there is no need to externally interface it. Graphical Display is used for displaying signals because of its better features. The basic parts of oscilloscopes are probes for sensing signal values, and switches to make device user friendly. Switches are provided for adjusting Voltages, Frequency and its time base. This is a design of oscilloscope for medium range frequencies.

II. SYSTEM OVERVIEW

ARM7 is one of the widely used micro-controller family in embedded system application. LPC2148 is the widely used IC from ARM-7 family. It is manufactured by Philips and it is pre-loaded with many inbuilt peripherals making it more efficient and a reliable option for the beginners as well as high end application developer. ARM7 has Princeton memory architecture.

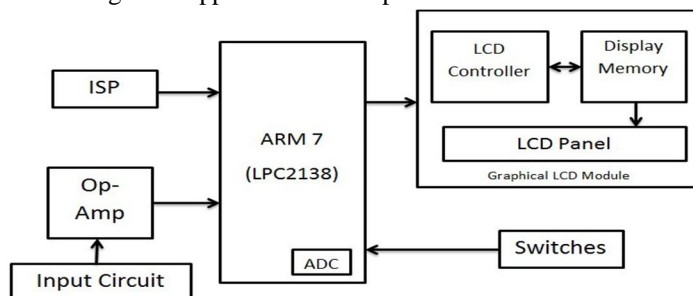

Figure 2.1: Block Diagram

As ARM consists of in-build ADC, there is no need to externally interface it. So the sensed signals from probe are directly send to the microprocessor, where it is converted to its digital value. ARM processor will sit ideal until a new data or digital value is sensed at probes. Then it will pass the data to being displayed on GLCD. At some point of time tuning and altering of waveform is also required, for its proper demonstration. Switches are provided for adjusting voltages, frequency and its time base. The values of voltage and frequency are chosen such that the waveform is displayed in an appropriate manner. Triggering is also an important factor because if its value is not properly set then waveforms will not be shown. This will be a design of auto triggering. In this type of designs user does not have to take care of horizontal and vertical triggering

III.HARDWARE DETAILS

A. LPC2148

ARM LPC2148 is used as a controlling device and graphical display for displaying signals. Probes will be there for testing circuit. The probes will be similar to as used in bigger oscilloscopes. By using ARM it will be an easier task to sense a particular signal and control it. As ARM consists of in-build ADC, there is no need to externally interface it. So the sensed signals from probe are directly send to the microprocessor, where it is converted to its digital value. ARM processor will sit ideal until a new data or digital value is sensed at probes. Then it will pass the data to being displayed on GLCD. At some point of time tuning and altering of waveform is also required, for its proper demonstration. Switches are provided for adjusting voltages, frequency and its time base. The values of voltage and frequency are chosen such that the waveform is displayed in an appropriate manner. Triggering is also an important factor because if its value is not properly set then waveforms will not be shown. This will be a design of auto triggering. In this type of designs user does not have to take care of horizontal and vertical triggering[1].

B. A/D Converter

ARM provides an advantage of in-built ADC. This will minimize the hardware requirements of device. ARM has two in-built analog to digital converter, with the features as 10 bit successive approximation method is used for conversion in ARM7, input multiplexing approximation analog to digital converter and Measurement ranges 0 V to VREF (typically 3 V).

C. Comparator Circuit

In the comparator circuit, input is captured from an external source via BNC connector. This input signal may be AC or DC. Thus, firstly signal is passed through one op-amp to convert an input signal to DC signal and then the next operational amplifier will compare the input DC signal with a predefined voltage. If input signal is weak then it will amplify with respect to Vref, on the other hand if signal carries some sort of noise or errors it is also attenuated by using comparator. The output of comparator circuit is given to ADC0.0 channel. Only a single channel of Analog to digital converter is used because this is a single channel oscilloscope. Thus a single waveform will display at a time.

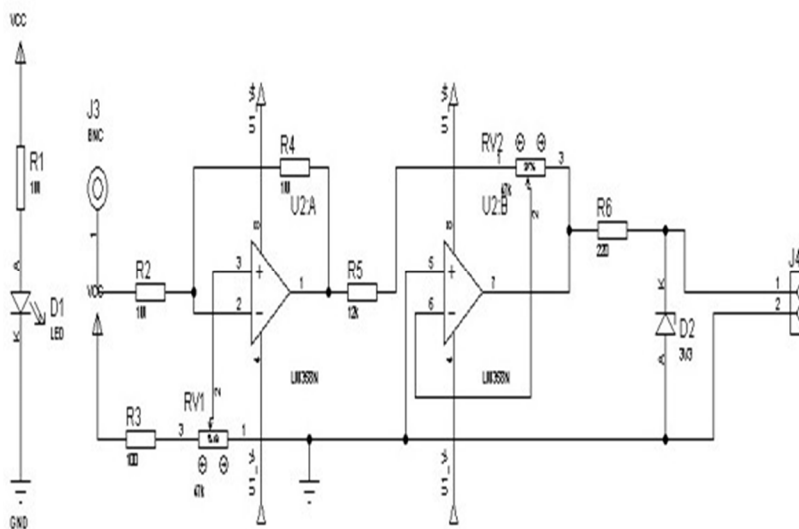

Figure 3.1: Comparator Circuit

D. Display Device

LCDs are used in a wide range of applications including televisions, computer monitors, aircraft cockpit displays, instrument panels, and signage. Graphical Liquid Crystal Displays add versatility to any project.

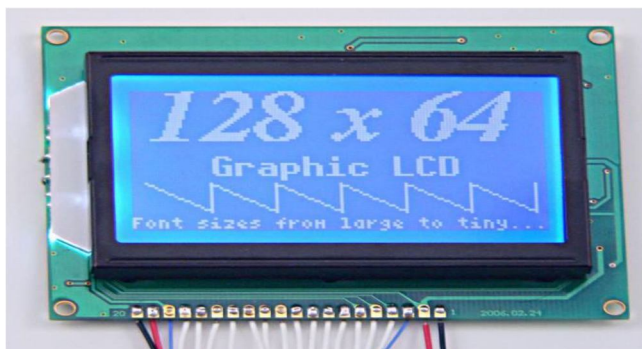

Figure 3.2: Graphical Liquid Crystal Displays

This GLCD is of 128 x 64 pixel. Graphic displays featured with a low-power LED-backlight. Brightness can be switched off and adjusted infinitely. Consumer devices such as clocks, video players, calculators, gaming devices, watches, and telephones are also some application of LCD. Graphical display devices replaced cathode ray tube (CRT) displays in most applications. Wider range of screen sizes is available for GLCD than CRT and plasma displays, and they do not use phosphors. The LCD screen is more energy efficient and can be disposed of more safely than a CRT.

IV. IMPLEMENTATION

This section describes how voltage and frequency are determined. To determine voltage and frequency, the input wave is sampled first and then further processed.

A. Voltage Determination

The heart of the computer-based data acquisition is usually the analog to digital converter (ADC). Basically this device is a voltmeter. Its input is voltage and its output is a digital number (a collection of 0's and 1's) proportional to the input voltage. The controller is usually programmed to convert this outputted digital number into a number that represents the measured voltage. The LPC 2148 consists of two 10 bit successive approximation ADC. Consider, for example, ADC designed to measure between 0 and 10 volts and convert this measurement into an 8-bit digital number. Then a 0 volt input is associated with the digital output of 0 (in binary 0000 0000) and a 9.999 volt input is associated with the digital output of 255 (in binary 11111111). In general the digital output of the ADC is related to the input voltage by the equation[2]:

$$\text{Digital Output} = \frac{\text{Integer part of } (256 * \text{Input Voltage})}{10}$$

If the input voltage is 4.78231415 volts then the ADC would produce the number 122 as its output. The computer program would then take this number and relate it with a voltage using the equation[2]:

$$\text{Voltage Reading} = \frac{\text{Digital Output} * 10}{256}$$

For this example this final conversion yields 4.78. Note that because the input was converted to an 8-bit integer in the middle of the process, a great deal of potential precision has been lost. For the 8-bit device with a range of 0-10 volt, the smallest change in the output reflects a difference of 0.039 volts (10 Volts/256) on the input. Thus the error caused by the processing of a signal through this ADC would be ±0.02 volts.

B. Frequency Determination

This section describes the implementation of a single pin measurement of frequencies up to 500 kHz using the Timer 2 counter input pin. The code written implements a frequency acquisition system that can be combined with a voltage measurement via the ADC to track both the frequency and voltage of the input signal. The measurement is displayed on a LCD screen. Since frequency is the number of cycles of a given waveform recorded over 1 second, both the number of cycles and the time taken for that number of cycles have to be measured. By measuring the number of cycles over 1 second, the frequency of the waveform is determined. In order to measure the number of cycles, a record of the number of times a 1-to-0 transition occurs on the waveform should be maintained. This is done using the Timer 2 counter input pin, which increments the Timer 2 registers on a 1-to-0 transition. There are two ways to measure a second. The first involves setting up Timer 0 with reload values such that it overflows when 10 ms has elapsed. By counting 100 of these overflows, a 1 second interval can be measured.

V. FLOWCHART

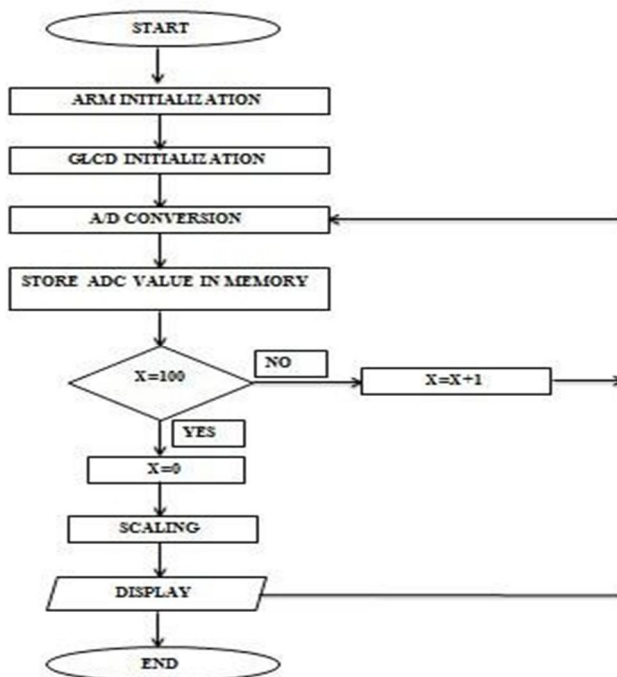

Figure 5.1: Flowchart

After the display of welcome screen, program will be at pause state until a "start" button is pressed. Whenever a new digital value appear at Analog to Digital Converter after real time sampling of input signal, that particular digital value is displayed on Graphical Display as a form of pixels. Graphical Display is of 128 x 64 pixels, In this 100 pixels are used for displaying signal and remaining 28 pixels for displaying digital values of voltage, frequency. This process will continue until device is in switch on mode.

VI. RESULT



Figure 6.1: 2V and 100Hz Sinosodal Wave



Figure 6.2: 3V and 1KHz Square Wave

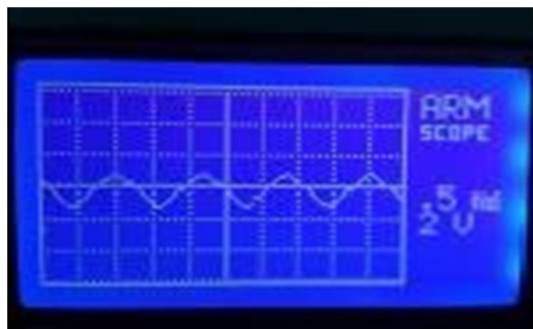

Figure 6.3: 2V and 1KHz Triangular Wave

VII. CONCLUSION

The usefulness of an oscilloscope is not limited to the world of electronics. The oscilloscope is low cost and avoid of the complexity use in the development of conventional scopes. It produces comparative results. It is a choice for all non-critical work that goes on every day in the laboratory and in out-of-lab measurements due to its portability. Initially the ARM Oscilloscope was tested feeding the signals from function generator. Provided facility for having different sampling rate and variable voltage divisions. The kind of input waveform, like sine wave, triangular wave, square wave or any other function can be continuously changed and tested in this oscilloscope.

REFERENCES

- [1] "The LPC2148 Introduction," IEEE White Paper, Nov. 2010.
- [2] Rajitha.G ,Venu.I, and Safia Shaik,"Implementation of ARM Based Digital CRO"International Journal of Science, Engineering and Technology Research (IJSETR), Volume 1, Issue 6,December 2012
- [3] Praveen Kumar.C.K. (2006), "PIC+ Graphical LCD based Mini-Oscilloscope for frequency stabilization of the External Cavity Diode Laser", International School of Photonics Cochin University of Science and Technology.
- [4] Sachin Shinde, Sapna Prabhu (Feb, 2013), "Labview Based Digital CRO For Electronic Measurement Techniques", Fr. Conceicao Rodrigues College Of Engineering, Bandra (w.) pp.693-698 ISSN: 2248-9622.
- [5] J. Karthika1, P. Karthik, "ARM 7 Based Portable Oscilloscope using LabVIEW", International Journal of Innovative Research in Electrical, Electronics, Instrumentation and Control Engineering ISO 3297:2007 Certified Vol. 4, Issue 10, October 2016.
- [6] Pereira, J.M.D., "The history and technology of oscilloscopes", Instrumentation & Measurement Magazine, IEEE Volume 9, Issue 6, 2006
- [7] M.M. VIJAI ANAND. (2002, December). PC-based Oscilloscope. [Online].Circuit1_oscilloscopr.pdf. http://www.electronicsforu.com/efylinux/circuit/dec2002/circuit1_oscilloscope.pdf.



10.22214/IJRASET



45.98



IMPACT FACTOR:
7.129



IMPACT FACTOR:
7.429



INTERNATIONAL JOURNAL FOR RESEARCH

IN APPLIED SCIENCE & ENGINEERING TECHNOLOGY

Call : 08813907089  (24*7 Support on Whatsapp)