



iJRASET

International Journal For Research in
Applied Science and Engineering Technology



INTERNATIONAL JOURNAL FOR RESEARCH

IN APPLIED SCIENCE & ENGINEERING TECHNOLOGY

Volume: 9 Issue: VI Month of publication: June 2021

DOI: <https://doi.org/10.22214/ijraset.2021.36157>

www.ijraset.com

Call:  08813907089

E-mail ID: ijraset@gmail.com

GSM based Energy Meter Monitoring and Load Control via SMS using Arduino

Kannan Kaliappan¹, Medishetty Manish Kumar², Boina Ramya³, Shaik Unnisa⁴, T Praveen Kumar⁵

^{1,5}Associate Professor, Department of EEE, Sreenidhi Institute of Science and Technology, Hyderabad, India

^{2,3,4}B.Tech Student, Department of EEE, Sreenidhi Institute of Science and Technology, Hyderabad, India

Abstract: *The main objective of the project is to develop a GSM based energy meter reading system and load control through SMS. Electricity department sends employees to take meter reading every month, which is an expensive and time consuming job. The proposed project provides a convenient and efficient method to avoid this problem. The electricity department and the user can get the readings of the energy meter of consumers via SMS. The loads can also be controlled by the user of this system via SMS using this project. A microcontroller input is effectively interfaced to a digital energy meter that takes the reading from the energy meter and displays the same on an LCD. The reading of the energy meter is also sent to the control room by an SMS via SIM loaded GSM modem. This GSM modem can also receive commands from the cell phone to control the owner's electrical loads. It uses a standard digital energy meter that delivers output pulses to the microcontroller to perform counting for necessary action. On receiving command it can switch ON/OFF the loads.*

Keywords: *Energy Meter, GSM modem, Arduino, load control*

I. INTRODUCTION

Gsm based energy meter monitoring and load control via sms using Arduino is a device, that not only calculate the monthly electric bill of consumer, as well as it also has a capability to control the load of user defined area. Beside this, the user can get their home load information and on or off their loads with the help of mobile phone. In other words, it has dual function capability. So many systems are available in market like this, but they do not have dual function capability as well as their cost is also so much high. Beside this they are not so much efficient and reliable. We have designed this power meter billing plus load control using GSM system with the help of step down ac transformer, bridge rectifier, voltage regulator, LCD display, relay Driver, Max 232, energy meter, GSM modem and arduino. This power meter billing plus load control using GSM system controls the load of user defined area and calculate their monthly bill more efficiently and intelligently as compared to other systems. The block diagram of this Gsm based energy meter monitoring and load control via sms using Arduino with all their essential components is shown below.

This project has been divided into various parts namely

- 1) Smps
- 2) Energy meter
- 3) Relay
- 4) Aurdino
- 5) GSM modem
- 6) LCD Display
- 7) Level Shifter IC
- 8) Opto isolator

In this project we use 220 volts of AC supply this 220 volts has been stepped down to 12 years DC with the help of SMPS. Relay are used at the output side when one command is sent then 1 relay will be on and when another command is sent then the relay will be off. The relay works on 12 volt dc.

II. ENERGY METER

An electricity meter, electric meter, electrical meter, or energy meter is a device that measures the amount of electric energy consumed by a residence, a business, or an electrically powered device. Electric utilities use electric meters installed at customers' premises for billing and monitoring purposes. They are typically calibrated in billing units, the most common one being the kilowatt hour (kWh). They are usually read once each billing period.

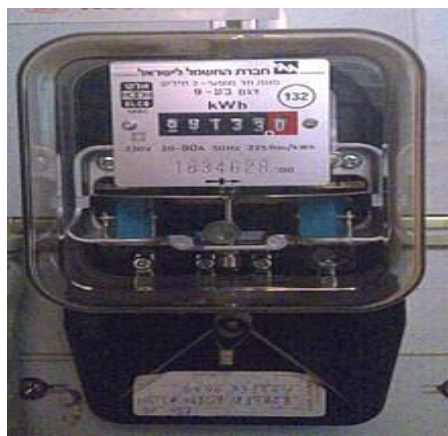

Fig. 1. Energy meter

Electricity meters operate by continuously measuring the instantaneous voltage (volts) and current (amperes) to give energy used (in joules, kilowatt-hours etc.). Meters for smaller services (such as small residential customers) can be connected directly in-line between source and customer. For larger loads, more than about 200 ampere of load, current transformers are used, so that the meter can be located somewhere other than in line with the service conductors. The meters fall into two basic categories, electromechanical and electronic.

III. ARDUINO

Arduino is a tool for making computers that can sense and control more of the physical world than your desktop computer. It's an open-source physical computing platform based on a simple microcontroller board, and a development environment for writing software for the board.

Arduino can be used to develop interactive objects, taking inputs from a variety of switches or sensors, and controlling a variety of lights, motors, and other physical outputs. Arduino projects can be stand-alone, or they can communicate with software running on your computer (e.g. Flash, Processing, MaxMSP.) The boards can be assembled by hand or purchased preassembled; the open-source IDE can be downloaded for free.

The Arduino programming language is an implementation of Wiring, a similar physical computing platform, which is based on the Processing multimedia programming environment.

There are many other microcontrollers and microcontroller platforms available for physical computing. Parallax Basic Stamp, Netmedia's BX-24, Phidgets, MIT's Handy board, and many others offer similar functionality. All of these tools take the messy details of microcontroller programming and wrap it up in an easy-to-use package. Arduino also simplifies the process of working with microcontrollers, but it offers some advantage for teachers, students, and interested amateurs over other systems.

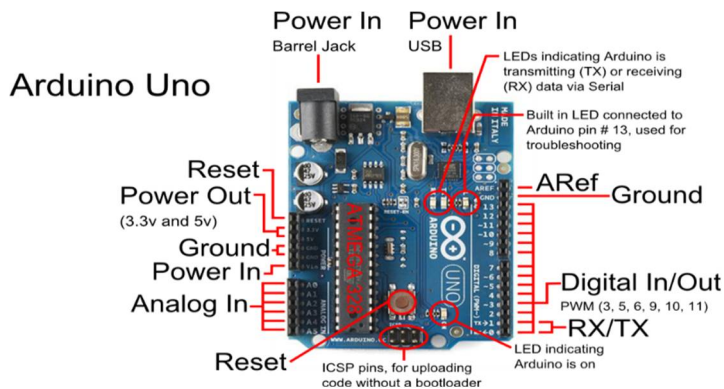

Fig.2. Arduino

IV. BLOCK DIAGRAM

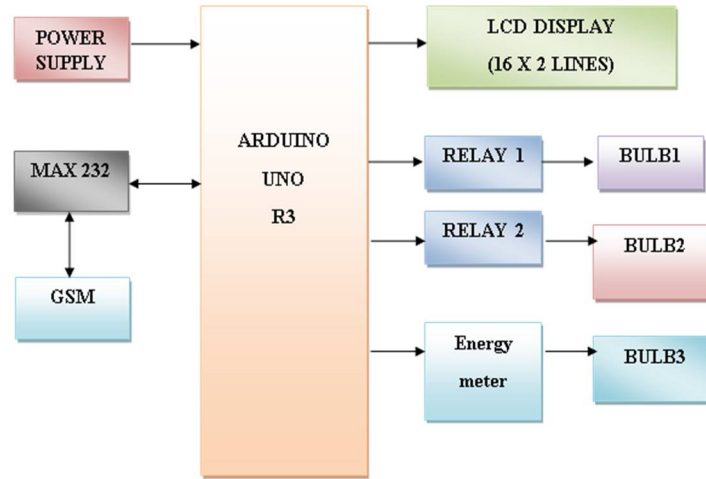

Fig. 3. Block Diagram

V. SCHEMATIC DIAGRAM

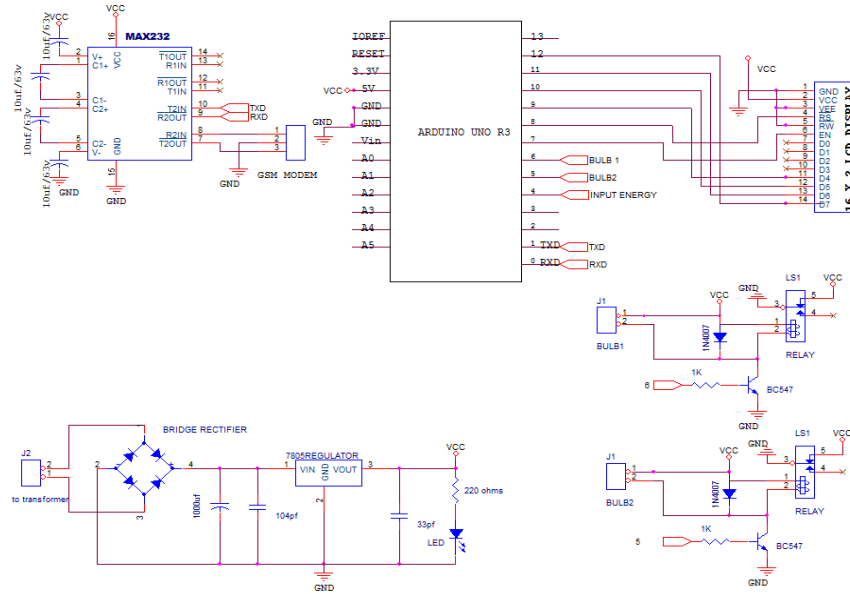

Fig.4.Schematic Diagram

VI. WORKING

This project consists of blocks like Arduino UNO, Energy Meter, Power Supply, GSM modem, LCD display, Relay. Out of this Arduino UNO is controlling part of this smart energy meter. Energy meter plays another important role in this system and it is used for live reading of electricity consumption that is interfaced with the controller to communicate with server and to operate according to server commands. Various Household Appliances consumes energy, the energy meter also consumes energy from the load and analyses the reading continuously. The load consumed is seen on the meter continuously. The Supply to the Energy Meter is controlled by the Relay Circuit that avoids the excess voltage to the Energy meter thereby saving the Energy meter from damage. The LED on that meter will continuously blink and the meter readings are counted. Normally, 3200 blinks is one unit. Arduino Uno act as main controller, and it continuously monitors the energy meter. The Arduino is provided with the External Power Supply.

Based on the blinking of LED on energy meter, the Arduino will measure the unit consumption. The measured reading and the cost will be displayed on the LCD and the amount of energy consumed and the bill amount to be paid will be sent to the Consumer and to the Electricity board through the GSM Module. Finally the overall monthly bill will be sent to customer as well as service provider in the form of text at first day of every month.

For switching on or off the output loads, odd numbers such as 1,3,5 are configured for switching on and even numbers such as 2,4,6 are configured for switching off the output loads. These numbers are configured through Arduino programming. For example, when the user sends the message after writing number 1 or 3 then this message is received by Arduino through GSM modem. Then Arduino switch on that specific load. Similarly, for switching off that specific load the user will send the message after writing number 2 or 4 then that load would be switched off. During this the switching status will be also displaying on LCD display. Similarly, this power meter billing plus load control using GSM system also calculate the bill of this load and estimate the cost of this bill after every 10 pulses or unit. After estimating this cost, this system sends the intimation message to the user or consumer. So, the user can easily know the monthly bill and control billing cost by planning the related loads.

VII. CONCLUSION

GSM based energy meter is easy installation and beneficial for both energy Provider and Customer. This reduces the manual cost and also reduces the errors done by the humans. This also reduces the problems faced by customer like over running of the meter, over load, and also reduces thefts. Whenever fault occurs it indicates to the customer. Then customer can inform to the company then energy Provider Company can cut the power easily by sending the SMS to that particular ID number which is connected to the SIM number. The statistical load used and profile help the customer to manage their energy consumption. This helps them to reduce their outstanding dues. This system can be used even in the remote areas by changing the type of the modem, and its range of frequency for communication. This device reduces all cases of revenue problems to the country and helps us to improve our usage.

VIII. FUTURE SCOPE

As there are plenty of ideas and innovation that one could implement, there are also many innovative ideas that can be processed further or extended further in our project. Since here we are concentrating on the provider side, i.e. at the ELECTRICITY BOARD. One can also include the features related to the customer side, ie making the fixed usage manual, thus by making the recharge of a particular amount, customer will be allowed to use the supply depending upon the plan selected as similar to the PREPAID sim card systems, which would enhance the experience of the economic consumer with modern digital utility meter. One can also include the feature of INSTANT BILL, at any instant of the time. By this feature consumer can know his/her bill at any interval of the month, so that an economical consumer can vary his/her consumption. Also a timer control can be provided, which would automatic cut down the system supply, if the payment of bill is not done in the specified time limit.

REFERENCES

- [1] W.Amer, Y. Attitude, A. Nadee m, Abdul Ghafoor 2010. Comprehensive E-monitoring, E-management and E-billing system with ZOOM-in ZOOM-out Capabilities to Reduce Electricity Distribution Loses for Developing Countries. 4th IEEE Annual System Conference, PP:174-177.
- [2] Shi Wei Lee, Design of an Automatic Meter Reading System, IEEE IECON 22nd International conference, Aug 1996.
- [3] En. wikipedia.org/wiki/smgs
- [4] H.G.Rodney, Tan IEEE, C.H.Lee and V.H.Mok, 2007. Automatic Power Meter Reading System using GSM Network. The 8th International Power Engineering Conference, PP: 465-469 T.Chandler, The Technology Development of automatic metering and monitoring systems, IEEE International Power Engineering Conference, Dec 2005
- [5] Power Meter Store. Measure Power at the plug. Web. 30 november 2010



10.22214/IJRASET



45.98



IMPACT FACTOR:
7.129



IMPACT FACTOR:
7.429



INTERNATIONAL JOURNAL FOR RESEARCH

IN APPLIED SCIENCE & ENGINEERING TECHNOLOGY

Call : 08813907089  (24*7 Support on Whatsapp)