



IJRASET

International Journal For Research in
Applied Science and Engineering Technology



INTERNATIONAL JOURNAL FOR RESEARCH

IN APPLIED SCIENCE & ENGINEERING TECHNOLOGY

Volume: 9 Issue: VII Month of publication: July 2021

DOI: <https://doi.org/10.22214/ijraset.2021.36307>

www.ijraset.com

Call:  08813907089

E-mail ID: ijraset@gmail.com

Design and Fabrication of Solar Operated Car

Mr. S.D.Bhadke¹, Mr. M. H. Bawankule², Mr. A. A. Gupta³, Mr. M. V. Thaware⁴, Prof. Mohan Karambe⁵

^{1, 2, 3, 4}Student, ⁵Guide, Govindrao Wanjari College Of Engineering and Technology Nagpur, Mechanical Engineering Department (GW CET)

Abstract: This work, focused on an idea about hybrid solar car technology which solves the major problem of fuel and pollution in present days. Determine how feasible widespread change to hybrids would be in future with all information taken into account, concluded that hybrids have several advantages as fuel efficient, low pollution. In the present work a complete drawing and drafting of hybrid solar car have been prepared using CATIA V5R19 software. After complete analysis of this drawing by using ANSYS 14.5 it is find out bear capability of load, stress, and strain of front & rear collision of car frame. A completed data are analyzed to examine the technical aspects of the hybrid car technology. Overall, hybrid technology has a lot of potential in the distant future, but as for right now they are not a significant applied over today's internal combustion engine.

Keywords: BLDC motor, Chassis, Design, solar Vehicle, Fabrication, CATIA.

I. INTRODUCTION

The Solar power is an increasing market for more developed countries, which can benefit from less electric expense over time. It is also good for the environment because it replaces the traditional, and in effect harmful, methods of energy production. There are other renewable energy sources besides solar, but it is especially practical for sunny areas which have less wind and water resources. Applications for this energy source can be from single houses and large electrical grids to cars, exhibiting a versatility perfect for the needs of a developing country.

A solar car is a solar vehicle used for land transport. Solar cars combine technology typically used in the aerospace, bicycle, alternative energy and automotive industries. The design of a solar vehicle is severely limited by the amount of energy input into the car. Most solar cars have been built for the purpose of solar car races. Since 2011 also solar powered cars for daily use on public roads are designed. Solar cars depend on PV cells to convert sunlight into electricity. PV cells directly convert sunlight into electricity. When sunlight (photons) strikes PV cells, they excite electrons and allow them to flow, creating an electrical current. PV cells are made of semiconductor materials such as silicon and alloys of indium, gallium and nitrogen. Silicon is the most common material used and has an efficiency rate of 15- 20%.

The brief study of hybrid solar car is efficient in our daily life because now day 's pollution and fuel rate is very big problem many people having fuel cars. Use of solar energy is being used for car, besides the control of vehicular pollution in the city, less consumption of fuel, Hybrid solar car are effective reducing global warming and environment problem in big frame. In the present work, the objective of this work is to estimate the potential of both energy as PV energy and mechanical engine power, both powers will be utilized in running car with weight reduction can be achieved primarily by the introduction of better material, design optimization and better manufacturing processes. The hybrid solar car is one of the potential items for weight reduction in hybrid solar car as it accounts for 5% - 10% of the weight. Various advantages for hybrid solar car by using solar technology

- A. Reduction in conventional car demand in urban city
- B. Minimum the pollution problem in urban city
- C. Give clean energy which will reduce the carbon dioxide emission every month

II. LITERATURE REVIEW

In this paper present with a detailed study of optimal sizing, fuel consumption of a solar car based on a longitudinal vehicle dynamics mode and energy flow, weight, overall cost of vehicle. It is shown that fuel saving can be achieved for intermittent use with average power and economic feasibility. Hybrid Solar Vehicles (HSV), derived by integration of Hybrid Electric Vehicles with Photo-Voltaic sources, may represent a valuable solution to face both energy saving and environmental issues, particularly in urban driving. This paper is also focuses on the general, technological issues and challenges ahead of plug-in hybrid electric vehicles in relation to major components which can be used for detail of design consideration and selection of component for electric motor and battery bank, control strategy. Other technical challenge as

light weight material used in a vehicle, low resistance tire and better aerodynamic structure of its .it type of vehicle is importance of economies and successful deployment of this plug- in hybrid technology we investigate the use of photovoltaic systems as auxiliary power generators in hybrid and electric vehicles. This technology provides an as yet unexploited possibility with the advantages of a new power source, which is light, noiseless, maintenance-free and continuously working.

III. METHODOLOGY

The design process of the entire vehicle is composed of two phases: conceptual and preliminary. In conceptual design, the basic configuration arrangement, size, weight, and performance are calculated. Then, designing the CAD model of individual parts in order to meet the required targets and optimizing it are done in preliminary design. The design requirements are used to guide and evaluate the development of the overall vehicle configuration.

After determining the important features of the problem, the following procedural steps are followed to solve it.

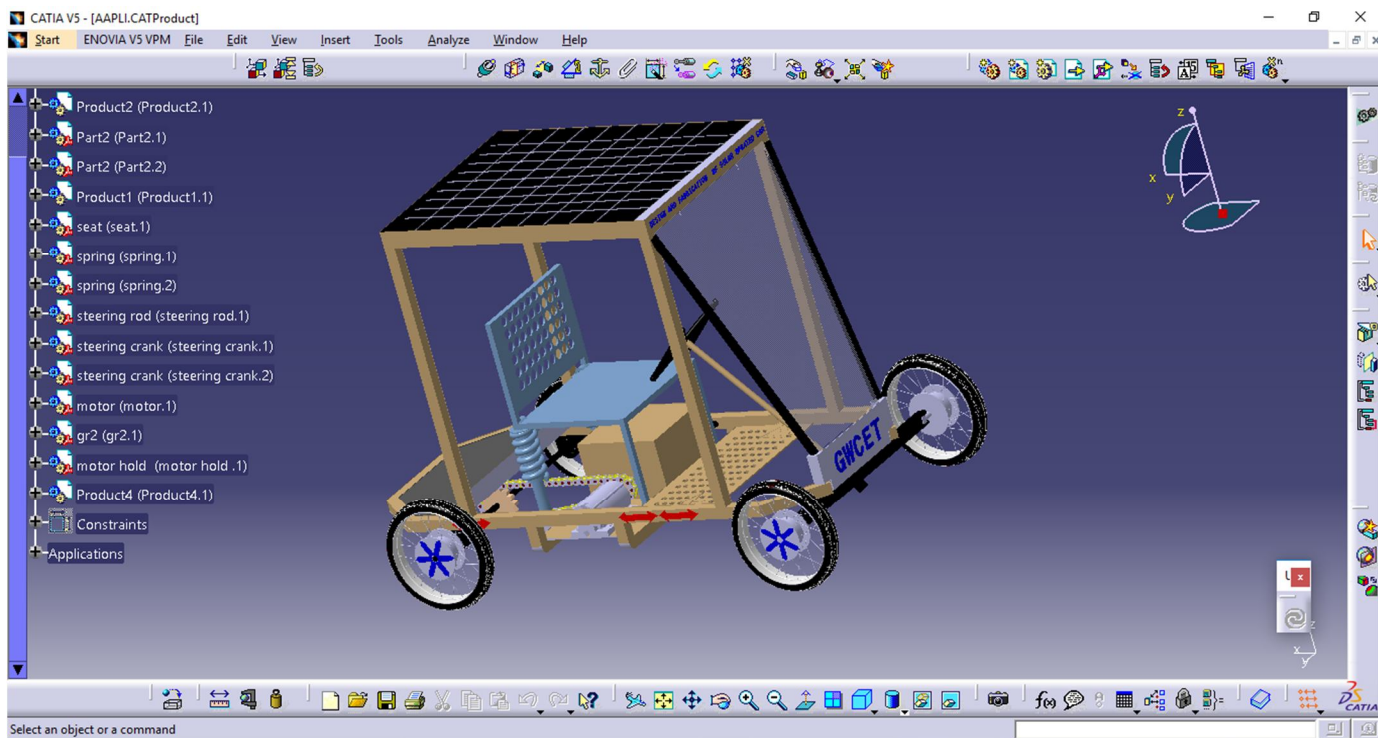

Fig. 1 cad model of a solar operated car

- 1) To develop a CAD model by using “CATIA V5 R19” software.
- 2) Export this model in “igs” (initial graphics exchange specification) format to ANSYS workbench.
- 3) With the help of ANSYS (workbench) analysis of static stresses is done.
- 4) Finally confirm the FOS(factor of safety) of CAD model and compare FEA(finite element analysis) result with analytical solution.

IV. DESIGN PARAMETERS

| PARAMETERS | DIMENSIONS |
|--|------------|
| Length | 1750mm |
| Weight | 780 mm |
| Height of C.G from the base of the chassis | 2020 mm |

Table 1 dimensions of solar car

V. DESIGN CONSIDERATIONS

- A. Weight of the chassis should be as low as possible.
- B. The design should allow for a driver egress of 5 seconds.
- C. The driver should have a vision of 200 degrees with 100 degrees on either side.
- D. Driver comfort.
- E. The design of the chassis was modeled using Catia and Ansys software.

VI. STATIC LOADING

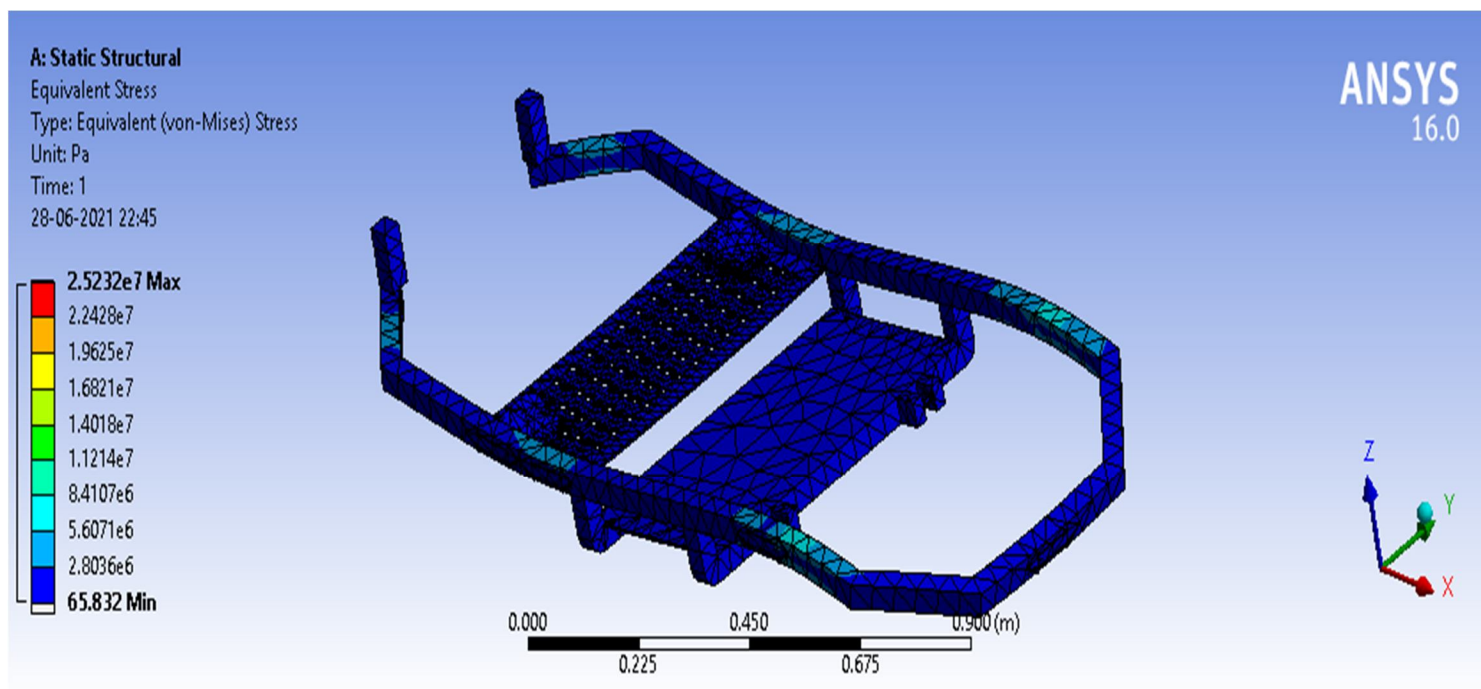

Fig. 2 analysis on chassis

It is the load acting on the chassis due to its own weight when the vehicle is in static condition. Mass of

driver=60 kg

Mass of total vehicle=190 kg

Now, Total mass = 250 kg Vertical force including gravity = $250 \times 9.81 = 2452.5 \text{ N}$ - 2500N (Here $G = 2500 \text{ N}$).

Total load = $3 \times G = 7500 \text{ N}$

VII. CONCLUSION

Suitable design based analysis of hybrid solar car has been given and results of battery bank and sizing, total area of car which can be used in PV array, capacity of total load and analysis of car body have been tabulated .

It will be used for research work and education purpose. In future this type of car have lot of marketing value because it will be used nonrenewable resource and renewable energy .This type of car does not create any pollution so it is also have a lot of positive point toward nature . Only the manufacturing cost is high but maintenance cost is almost zero. Hence this car is economic and environmental friendly

VIII. ACKNOWLEDGMENT

This paper is based on a real time project carrying out by the students of GWCET, Nagpur. The vehicle is made possible with the help and assistance provided by Mr. Karambe sir Assistant professor, GWCET, Nagpur. The project is taken by a team of 11 members.



REFERENCES

- [1] Arsie I, Rizzo G, Sorrentino M "A Model for the Optimal Design of a Hybrid Solar Vehicle", Review of Automotive Engineering, Society of Automotive Engineers of Japan (JSAE), 2008, ISSN 1349-4724. 29-3: 439-447
- [2] Preitl Z., Bauer P., Kulcsar B., Rizzo G., Bokor, J. "Control Solutions for Hybrid Solar Vehicle Fuel Consumption Minimization In: Proceedings of the 2007 IEEE Intelligent Vehicles Symposium, Istanbul, Turkey, June 13-15, 2007.
- [3] Egiziano L., Giustiniani A., Lisi G., Petrone G., Spagnuolo G., Vitelli M., "Experimental characterization of the photovoltaic generator for hybrid solar vehicle". Proc of 2007 IEEE International Symposium on Industrial Electronics, June 4-7 2007 Vigo (Spain), pp 329-334
- [4] Srdjan Lukic M., Mulhall P., Choi G., Naviwala M., Nimmagadda S., and Emadi, A. , Usage Pattern Development for Three-Wheel Auto Rickshaw Taxis in India .pp (610-616) in 2007 IEEE
- [5] Arsie I, Rizzo G, Sorrentino M, Effect of engine thermal transients on the management of series Hybrid solar vehicles, International journal of control engineering practice, (2010) pp1231-1238



10.22214/IJRASET



45.98



IMPACT FACTOR:
7.129



IMPACT FACTOR:
7.429



INTERNATIONAL JOURNAL FOR RESEARCH

IN APPLIED SCIENCE & ENGINEERING TECHNOLOGY

Call : 08813907089  (24*7 Support on Whatsapp)