



IJRASET

International Journal For Research in
Applied Science and Engineering Technology



INTERNATIONAL JOURNAL FOR RESEARCH

IN APPLIED SCIENCE & ENGINEERING TECHNOLOGY

Volume: 9 Issue: VII Month of publication: July 2021

DOI: <https://doi.org/10.22214/ijraset.2021.36411>

www.ijraset.com

Call:  08813907089

E-mail ID: ijraset@gmail.com

Arduino Based Solar Tracking System for Energy Improvement of PV Solar Panel

Smita Dinker¹, Dr. Anil Kumar², Dr. Akhilendra Yadav³

^{1,3}Electrical and Electronics Department, SRMSCET Bareilly, Bareilly, U.P. India

²HOD of Electrical Department, IFTEM University, Moradabad, U.P. India

Abstract: Solar energy is a clean, easily accessible and abundantly available alternative energy source in nature. Getting solar energy from nature is very beneficial for power generation. Using a fixed Photovoltaic panels extract maximum energy only during 12 noon to 2 PM in Nigeria which results in less energy efficiency. Therefore, the need to improve the energy efficiency of PV solar panel through building a solar tracking system cannot be over-emphasized. Photovoltaic panels must be perpendicular with the sun in order to get maximum energy. The methodology employed in this work includes the implementation of an Arduino based solar tracking system. Light Dependent Resistors (LDRs) are used to sense the intensity of sunlight and hence the PV solar panel is adjusted accordingly to track maximum energy. The mechanism uses servo motor to control the movement of the solar panel. The microcontroller is used to control the servo motor based on signals received from the LDRs. The result of this work has clearly shown that the tracking solar panel produces more energy compared to a fixed panel.

Keywords: Solar Tracking System (STS), Photovoltaic Modules, Microcontroller.

I. INTRODUCTION

Nigeria is among the tropical countries that fall between 4 degrees and 13 degrees and enjoys sunshine of 6.25 hrs daily. Presently, public electricity covers only 40% of Nigerian homes and this is not still on a consistent basis. Due to lack of constant power supply in Nigeria, people have started embracing the culture of generating their own power supply. The use of fossil fuels as a means of generating electricity has become expensive making cost of living very high, especially in the rural part of the country. Also the use of fossil fuel has brought about pollution to the environment which in turn is not safe for our health. It releases carbon dioxide which causes the greenhouse effect. This brings about the deforestation of land and also the pollution of air and water. Solar energy is gotten solely from the sun and as a result does not emit carbon dioxide which prevents the green-house effect. The development of solar energy in Nigeria has the potential to create jobs. Employment in renewable energy industry would reduce occupational hazards especially when compared to coal mining and the extraction of oil. Nowadays solar energy is becoming one of the most reliable sources of energy as a result of its surplus and environmental friendly [1]. According to reference [2] a system that tracks the sun will be able to know the position of the sun in a manner that is not linear. The operation of this system should be controlled independently [3]. Maximum energy is produced by a solar PV panel when it is positioned at right angle to the sun. Therefore, the aim of this research is to develop an Arduino based solar tracking for energy improvement of solar PV panel.

II. LITERATURE REVIEW

An A solar cell is a device which converts light energy to electrical energy through photovoltaic effect. Solar cells are the building blocks of photovoltaic modules known as solar panels. In solar tracking system, the module's surface tracks the position of the sun automatically as the day runs by. The position of the sun varies as the sun moves across the sky. For a solar powered equipment to work best, it must be placed near the sun and the solar tracker can increase the efficiency of that equipment at any fixed position. Based on sophistication, costs and performance. One common type of tracker is the heliostat, a movable mirror that reflects the position of the sun to a fixed location. Solar trackers accuracy depends on the application. Concentrators, especially in solar cell applications, require a high degree of accuracy to make sure that the concentrated sunlight is directed exactly to the powered device, which is close to the focal point of the reflector or lens. Without tracking, concentrator systems will not work at all, therefore single-axis tracking is mandatory [4]. Non-concentrating applications require less accuracy, and many are likely to work without any tracking. However, tracking with great effect can improve both the amount of total output power produced by a system and that produced during critical system demand periods (usually late afternoon in hot climates) [5]. Researches have been done to improve the energy production of solar panels.

These researches include; double-sided panels [6], conversion stages improvement [7], building panels integration geometrically [8] and so on. Maximum energy is produced by a solar PV panel when it is positioned at right angle to the sun. For this reason, several researches developed different types of solar panel tracking systems [9 and 10]. Therefore, the primary purpose of this work is to develop a solar panel tracker based on Arduino advances so as to enhance the energy production of solar panel.

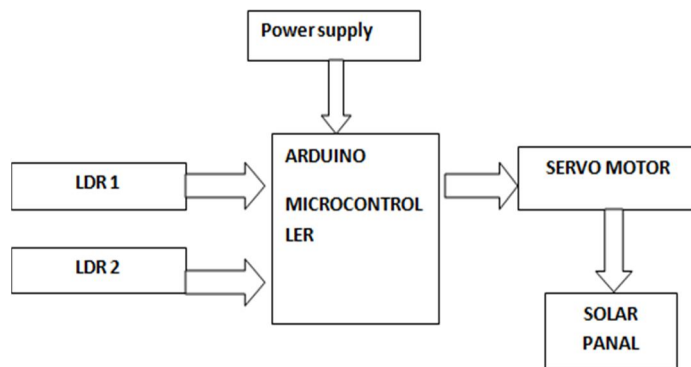

Fig-1 The Solar tracking system block diagram.

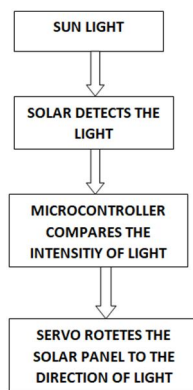

Figure 2: Flow chart diagram of the solar tracking system

This solar panel tracking system simulation was performed using a Proteus software. A Simulation was carried out to know if the system designed and implemented will perform to our expectation or not. Simulation process reveals the exact circuit diagram and connection of the system. The simulation carried out is shown in figure 3 which performed as desired. We then carried out experimental observation between fixed solar panels and the implemented tracking solar panel to compare the performance enhancement of the implemented tracking solar panels and the fixed solar panels. We used 6W solar panel made of the same material and manufacturer.

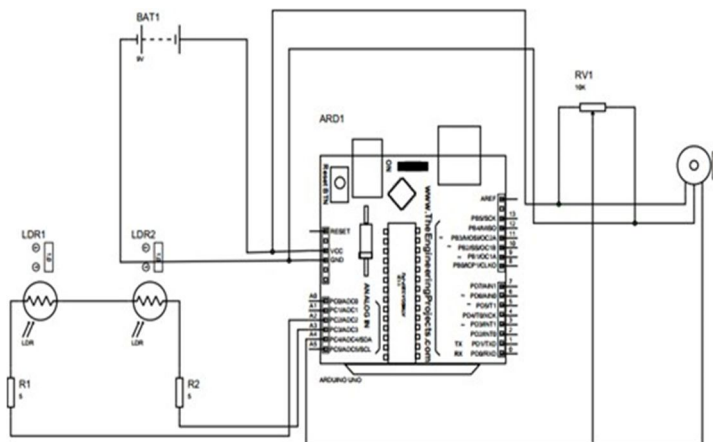

Figure 3: Schematic diagram of the solar panel tracking system.

III. RESULT ANALYSIS

The power readings of the fixed solar panel and the implemented tracking solar panel were taken hourly for three days in the year 2017 and recorded as shown in tables 1, 2, and 3. Results taken on different days show the difference in efficiency between the fixed solar panel and the implemented solar tracker.

Table 1: Power readings for a cloudy morning and sunny afternoon, 11th of March 2017

Time	Power reading of fixed solar panel (6W)	Power reading of the implemented tracking solar panel system (6W)
7.00	0.176	1.487
8.00	0.210	1.839
9.00	0.196	2.933
10.00	0.567	3.783
11.00	0.816	3.798
12.00	2.297	3.969
1.00	4.941	4.990
2.00	3.910	4.990
3.00	4.057	4.985
4.00	3.846	4.892
5.00	1.544	4.594
6.00	1.144	2.981

Table 2: Power readings for a bright sunny day, 12th March 2017

Time	Power reading of fixed solar panel (6W)	Power reading of the implemented tracking solar panel system (6W)
7.00	0.679	1.477
8.00	0.792	2.804
9.00	1.779	3.203
10.00	3.167	3.990
11.00	3.421	4.130
12.00	4.604	4.800
1.00	4.990	4.990
2.00	4.980	4.988
3.00	4.888	4.976
4.00	4.413	4.941
5.00	3.935	4.873
6.00	2.639	3.964

Table 3: Power readings for a bright sunny day, 13th March 2017

Time	Power reading of fixed solar panel (6W)	Power reading of the implemented tracking solar panel system (6W)
7.00	0.489	1.487
8.00	1.061	2.839
9.00	1.672	3.990
10.00	1.199	3.990
11.00	3.226	4.149
12.00	3.208	4.590
1.00	4.980	4.990
2.00	4.990	4.990
3.00	4.941	4.985
4.00	3.878	4.892
5.00	3.824	4.790
6.00	2.639	3.940

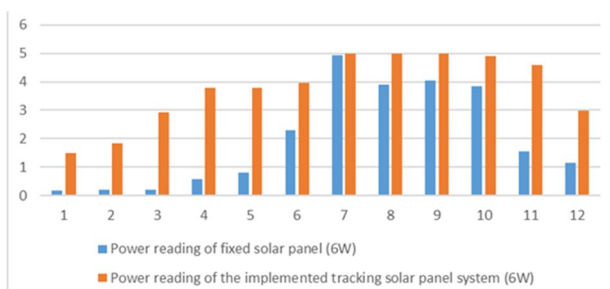

Figure 4: Graph of power readings for a cloudy morning and sunny afternoon, 11th March, 2017.

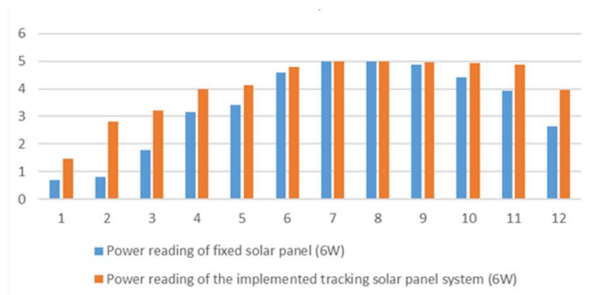

Figure 5: Graph of power readings for a bright sunny day, 12th March, 2017.

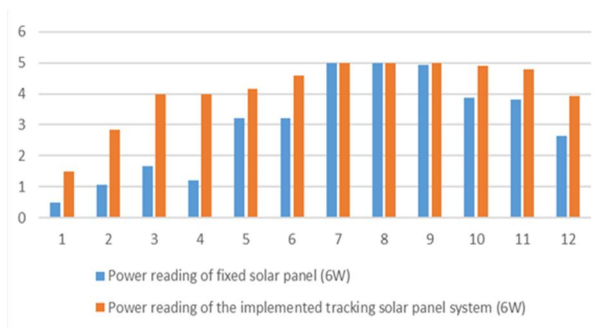

Figure 6: Graph of power readings for a bright sunny day, 13th March, 2017.

From the above tables, it is observed that the maximum sunlight occurs at around midday, with the values being maximum between 1200 hours and 1500 hours. In the morning and late evening, intensity of sunlight reduces and the values obtained are less than the values obtained during the day. After sunset, the tracking system is switched off to save energy. It is then switched back on in the morning to continue tracking. When the values are the same the motion of the panel stops, meaning the LDRs receive the same intensity of sunlight.

IV. CONCLUSION

A solar panel tracking system was designed and implemented. The aim of the solar panel tracking system is to track the position of the sun for better efficiency of the solar panel has shown in the experimental results. This work can be executed on an industrial scale which be beneficial to developing countries like Nigeria and Sub-Sahara Africa countries. Our recommendation for future works is to consider the use of more sensitive and efficient sensors which consume less power and which are also cost effective. This would increase the efficiency while reducing cost.

REFERENCES

- [1] Gonçalves, P.; Orestes, M. Photovoltaic solar energy: Conceptual framework. *Renew. Sustain. Energy* 2017, 74, 590–601.
- [2] M.T.A. Khan, S.M.S. Tanzil, R. Rahman, S.M.S. Alam. "Design and Construction of an Automatic Solar Tracking System." 6th International Conference on Electrical and Computer Engineering ICECE 2010, 18 – 20 December, Dhaka, Bangladesh.
- [3] B.A. Mork, W.W. Weaver, "Smart Grids and Micro Grids, where are they really." Minnesota Power Systems Conference, 3 -5 November 2009, Brooklyn Center, MN, USA.
- [4] A.K. Saxena and V. Dutta, "A versatile microprocessor based controller for solar tracking," in Proc. IEEE, 1990.
- [5] Yousef, H.A. Design and implementation of a fuzzy logic computer-controlled sun tracking system. In Proceedings of IEEE International Symposium on Industrial Electronics,
- [6] Lo, C.K.; Lim, Y.S.; Rahman, F.A. New integrated simulation tool for the optimum design of bifacial panel with reflectors panels on a specific site. *Renew. Energy* 2015, 81, 293–307.
- [7] Van der Meer, D.W.; Widen, J.; Munkhammar, J. Review on probabilistic forecasting of photovoltaic power production and electricity consumption. *Renew. Sustain. Energy Rev.* 2017.
- [8] Spertino, F.; Ahmad, J.; Ciocia, A.; Di Leo, P. Techniques and experimental results for performance analysis of photovoltaic modules installed in buildings. *Energy Procedia* 2017, 111, 944–953.
- [9] Quesada, G.; Guillon, L.; Rousse, D.; Mehrtash, M.; Dutil, Y.; Paradis, P.L. Tracking strategy for photovoltaic solar systems in high latitudes. *Energy Convers. Manag.* 2015, 103, 147–156.
- [10] Miloudi, L.; Acheli, D.; Ahmed, C. Solar tracking with photovoltaic system. *Energy Procedia* 2013, 42, 103–112.
- [11] Salem Farhan A. Mechatronics Design of Solar Tracking System, *International Journal of Current Engineering and Technology*. - taif : INPRESSCO, april 2013. - Vol. 3. - pp. 417-429.
- [12] Saxena A.K. and Dutta V "A versatile microprocessor based controller for solar tracking Photovoltaic Specialists Conference. - [s.l.] : IEEE, 1990. - pp. 1105-1109.
- [13] Shen C. Hua and C. Comparative study of peak power tracking [Conference] // *Applied Power Electronics*. - 1998. - Vol. 2. - pp. 679-685.
- [14] Tiberiu Tudorache Liviu Kreindler Design of a Solar Tracker System for PV Power 4Acta Polytechnica Hungarica. - Bucharest : [s.n.], 2010. - pp. 23-39.
- [15] Vilela OC Fraidenraich N, Tiba C. Photovoltaic pumping systems driven by tracking collectors:experiments and simulation, *Solar Energy*. - 2003. - Vol. 74. - pp. 45-52.
- [16] Y. Tao and W. Guo Study on tracking strategy of automatic sun-tracking system based on CPV Generation [Journal] // in Proc. ISDEA'. - 2010. - pp. 506-509.
- [17] Yu T C Chien T S Analysis and Simulation of Characteristics and Maximum Power Point Tracking for Photovoltaic Systems. *International Conference on Power*. - 2009. - pp. 1339-1344.
- [18] Yukio S. Takemaro and Shibata Theoretical Concentration of Solar radiation by sentral recieving system, *The International Journal of*. - 1983. - pp. 261-270.



10.22214/IJRASET



45.98



IMPACT FACTOR:
7.129



IMPACT FACTOR:
7.429



INTERNATIONAL JOURNAL FOR RESEARCH

IN APPLIED SCIENCE & ENGINEERING TECHNOLOGY

Call : 08813907089  (24*7 Support on Whatsapp)