



# IJRASET

International Journal For Research in  
Applied Science and Engineering Technology



---

# INTERNATIONAL JOURNAL FOR RESEARCH

IN APPLIED SCIENCE & ENGINEERING TECHNOLOGY

---

**Volume: 9      Issue: VII      Month of publication: July 2021**

**DOI: <https://doi.org/10.22214/ijraset.2021.36420>**

**[www.ijraset.com](http://www.ijraset.com)**

**Call:  08813907089**

**E-mail ID: [ijraset@gmail.com](mailto:ijraset@gmail.com)**

# Lineman Safety

Dr. Devika B<sup>1</sup>, Srilakshmi S<sup>2</sup>, Shabnam Ara Ahmed<sup>3</sup>, Yashaswini G<sup>4</sup>, Zaiba Anam<sup>5</sup>

<sup>1</sup>Assistant Professor, Department of Telecommunication, KSIT, Bengaluru, India

<sup>2,3,4,5</sup>UG Student, Department of Telecommunication, KSIT, Bengaluru, India

**Abstract:** *Electrical accidents to lineman are rising during electric line repair due to lack of communication between the maintenance staff and electric line man. This proposed system provides a solution that ensures safety of electric lineman i.e., line man on detecting a fault in electric line the line man senses his finger in fingerprint scanner and the main line is switched off which is again switched on after solving the fault by again sensing his finger, thus it saves the life of lineman working on electric line. The proposed system is fully operated on Arduino.*

**Keywords:** *RFID, Chip, Coil, Fingerprint Scanner.*

## I. INTRODUCTION

A world without electricity is hard to imagine. Electricity is now become a part of our daily life. Electricity plays major role in both homes & industries. Almost all devices at homes and industries are running because of electricity. As how, the electricity is important part in our life the electricians' life is also predominant one. They play the many roles in their field. A circuit breaker is an automatically operated electrical switch designed to protect an electrical circuit from damage caused by overload or short circuit. The main objective of this project is to save line man by making such a protective system controlled through fingerprint scanner. In this proposed system if there is any fault in line the line man scans his finger due to which main line is switched off after that he works on line solving the problem and after that again scans his finger and switch on the electrical line.

Nowadays, electrical accidents to the line man are increasing, while repairing electrical lines due to lack of communication between maintenance staff and electrical line man. This project gives a solution to this problem to ensure electric line man safety. It very simple to maintain so it is very useful for the line man. The parts which is required for our model is easily available in the market. The main goal of our project is to save the life of line man. The main component of our project is the fingerprint scanner which is required to sense the finger. At the time of repair, the electrocution to the lineman may happen. If the lineman wants to repair the power system then the maintenance staff turns off the respective power line in the main station. The main station and the fault detected power lines may be in different areas. Due to these the communication between the lineman and the maintenance staff may lack. Any other personnel in the main station or substation may mistakenly switch ON the power line without the knowledge of lineman while working on the power lines. This would tend to fatal electrical accident. This proposed system provides a solution that ensures safety of lineman. The control to turn ON/OFF the transmission lines will be maintained by the lineman only. The proposed system not only focuses on the safety of electrical lineman but also to provide the feasible system to control power lines. Now days, electrical accidents to the line man are increasing, while repairing the electrical lines due to the lack of communication between the electrical substation and maintenance staff. This project solution to this project to ensure line man safety. In this proposed system the control (ON/OFF) of the electrical line lies with line man. The based electric line man safety system is designed to control a circuit breaker by using a RFID and Fingerprint sensor for the safety of electric man, the line man can enter the Fingerprint through using Fingerprint sensor as well as keypad. There are many critical electrical accidents are rises during the electric line repair. These accidents happen due to lack of communication and co-ordination between the maintenance staff and electric substation staff. In this proposed system the security of the line man is in his own hand. The control to turn on or off the line will be maintained by the line man only because this system has an arrangement such that a fingerprint sensor is required to operate the circuit breaker (on/off). The system is fully controlled by a micro controller from ATMEGA328.

## II. LITERATURE SURVEY

In this paper, Micro controller are used which controls all the operations of the password system. For this process we require the components like micro controller control circuitry, power supply and key pad. These keypads are used for entering password for operating different load which are connected to the controller. If suppose password is wrong, then load will not be switched to the controller and then the controller checks for the precaution instruction which is provided by the developer. This includes the operations such as the number of loads to be opened, the number of threshold levels that are crossed. In this process the controller checks the number of threshold levels that are crossed and according to that the gates are being controlled [1].

A circuit breaker is an automatically operated electrical switch designed to protect an electrical circuit from damage caused by overload or short circuit. Its basic function is to detect a fault condition and interrupt current flow. Unlike a fuse, which operates once and then must be replaced, a circuit breaker can be reset (either manually or automatically) to resume normal operation. When operated manually we see fatal electrical accidents to the line man are increasing during the electric line repair due to the lack of communication and coordination between the maintenance staff and the electric substation staff. In order to avoid such accidents, the breaker can be so designed such that only authorized person can operate it with a password. Here, there is also a provision of changing the password. The system is fully controlled by the 8 bit micro controller of 8051 family. The password is stored in an EEPROM, interfaced to the micro controller and the password can be changed any time unlike a fixed one burnt permanently on to the micro controller. A keypad is used to enter the password and a relay to open or close circuit breaker, which is indicated by a lamp. Any wrong attempt to open the breaker (by entering the wrong password) an alert will be actuated, indicated by another lamp [2].

The paper provides a password based circuit breaker system using an android application. Here we connect the circuit with android application through which we enter the password. There is a substantial increase in the number of fatal accidents involving line men due to electric shocks resulting from the lack of coordination between maintenance staff and the electric substation staff. This system provides a solution to this problem, to ensure there are no such incidents that endanger the life of line men. Here the control of the circuit is provided at the substation. The line man can enter the password to switch OFF the circuit. He may now safely work out the repairs and may return to the substation to switch ON the circuit. He again needs to enter the password in order to switch ON the circuit. Since the control to switch ON/OFF the circuit lies with the lineman himself there is no chance of accidents. The system also provides password storage using EEPROM. This system also makes it possible to change the password as and when needed for security purposes [3].

The steadily increasing population has more demand and consumption of electric energy in the market as raised and that of equipment's used like electrical and electronics are also costlier. So to protect the electrical system from overload or short circuit here is one possibility, which is by ultra fast acting electronic circuit breaker. A circuit breaker is automatic operated switch designed to shut down the power supply when overloaded. The tripping depends on the current passing through the CT's which is connected in series with load. It uses the PIC- micro controller into which program is dumped for the operation [4].

The need for strict security measures has been necessary since the beginning of time. Access to certain places and items need strict restrictions to only the privileged few. This restricted zone can vary from strong holds and safes in financial institutions to doors leading to restricted areas. The various innovations in security access system include; code based lock, key card lock, thumb print scan, retina scan. They come in handy in security systems. Code based locking system is best suited in most applications because of its simplicity and reliability. Since the code based locking system is always resident in the area to be protected, there are fewer chances of security breaches unlike the key card lock system in which the access card can fall into unauthorized hands [5].

due to lack of communication and co-ordination between the maintenance staff and electric substation Staff. This proposed system provides a solution that ensures safety of maintenance staff, i.e., line man on detecting a fault in electric line the line man sends sms and the main line is switched off which is again switched on after solving the fault it can also prove a boon to save power thus it saves the life of lineman working on electric line. The proposed system is fully operated on micro controller [6].

A circuit breaker is an automatically operated electrical switch designed to protect an electrical circuit from damage caused by overload or short circuit. Its basic function is to detect a fault condition and interrupt current flow. Unlike a fuse, which operates once and then must be replaced, a circuit breaker can be reset (either manually or automatically) to resume normal operation. When operated manually we see fatal electrical accidents. The line man are increasing during the electric line repair due to the lack of communication and coordination between the maintenance staff and the electric substation staff [7].

The proposed system provides a solution that ensures safety of lineman. The control to turn ON or OFF the line is maintained by the lineman. The system has an arrangement such that a password is required to operate the doors of the control panel and circuit breaker (ON/OFF). A secured password is requested and received from the control room by the linemen for the point of repair or service. This request is registered and a password is sent to the lineman's mobile and control panel GSM module for the further work. The password is entered through the matrix keypad which is interfaced to the Arduino Uno micro controller. The entered password is compared with the password received by the control panel GSM receiver. If the entered password is correct then the circuit breaker ON/OFF and door OPEN/CLOSE feature is enabled for the lineman to take up repair. Any intruder tries to operate the mechanism with the wrong password by three times it will display a message in the LCD display and a message is sent to the control room regarding unauthorized accessing of the system for the safety reasons [8].

The main goal of this paper is to design and implement a security system based on RFID and GSM technology which can be organized in banks, secured offices and homes. Implemented security system based on RFID and GSM technology containing security system using RFID and GSM which can activate, authenticate, and validate the user. The main advantage of using passive RFID and GSM is more secure than other systems. This system consists of Actel FPGA, RFID reader, GSM modem, dsPIC and LCD. In this system the RFID reader reads the id or password number from passive tag and sends to the FPGA. FPGA checks the card is valid or not then sends data to the dsPIC, after that dsPIC micro controller displays the success or failure message on LCD and sends the SMS to the authorized person mobile number, which was stored in dsPIC [9].

The main purpose of this paper is to design and implement high security system. Security is a prime concern in our day-to-day life. Perhaps the most important application of accurate personal identification is securing limited access systems from malicious attacks. Access control system forms a vital link in a security chain. The fingerprint and password based security system presented here is an access control system that allows only authorized persons to access a restricted area. We have implemented a locker security system based on fingerprint, password and GSM technology containing door locking system which can activate, authenticate, and validate the user and unlock the door in real time for locker secure access. Fingerprints are one of many forms of bio metrics, used to identify individuals and verify their identity. This high security system based on fingerprint, password and GSM technology which can be organized in bank, secured offices and homes [10].

### III. METHODOLOGY

The block diagram consists of finger print scanner and it is enrolled by a lineman. This module is connected to the MCU. If the finger print stored in the scanner is with the authenticated finger print, MCU is turned on. This makes on or off the relay which helps to control the electric line. After the completion of the work, above process is repeated in the same manner by the lineman. When a person's fingerprint is changed, finger print scanner does not take this into consideration. In such cases, person can have the difficulty to identify themselves and gaining access. In such cases, RFID tag is used.

RFID uses electromagnetic fields to automatically identify and track tags attached to objects. The tags contain electronically stored information. These tags collect energy from a nearby RFID reader's interrogating waves. Active tags contain battery and it operate hundreds of meters from the RFID reader. The tag need not be within light of sight of the reader. RFID is used for security purpose. It consists of microchip and coil. To recognize the identity of RFID tag, RFID tag sends the signal to reader, the signal is received by coil and unique ID is identified by chip. The RFID is present on the shoes, gloves and hands. If the lineman wears all these things then it will allow for the further process. It is widely used in identification badges.

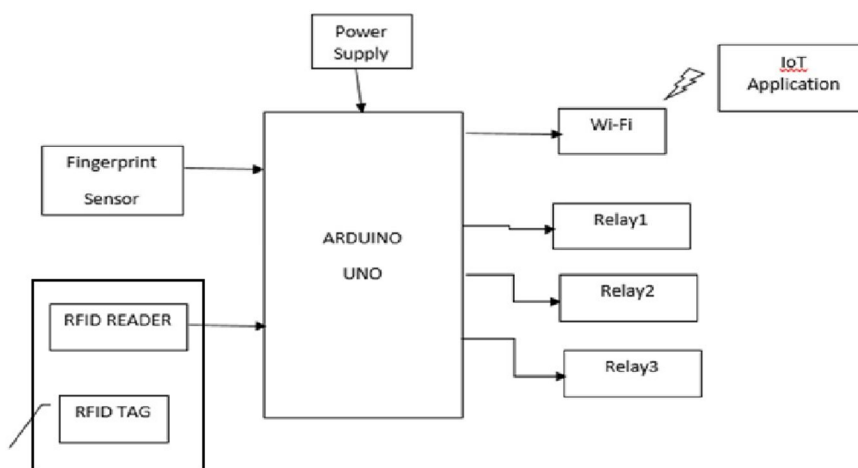

Figure 1: Block Diagram of the Lineman Safety

### IV. CONCLUSION

The proposed safety system is successfully designed. It provides a new approach to the security of the lineman and completely eliminates the fatal electrical accidents to the lineman due to electric shock during the power line repair. It has been developed by integrated features of all the hardware components used. It provides a new approach to the security of the lineman and it completely eliminates the electrical accidents to the lineman during the electric line repair. In order to note the power usage in a particular area in a timely manner, this power usage is uploaded in the internet.

## REFERENCES

- [1] Jay Kumar, Surya Kumar, Praveen Tyagy "PASSWORD BASED CIRCUIT BREAKER", International Journal of Recent Research Aspects ISSN: 2349-7688, Volume 3, Issue 1, March 2016.
- [2] J.Veena, Afreen, Sunil Kumar, Santhosh "ELECTRIC LINEMAN PROTECTION USING USER CHANGEABLE PASSWORD BASED CIRCUIT BREAKER", ISSN: 2393- 8374,VOLUME-2, ISSUE-5, 2015.
- [3] Santosh Ashok Kamble , "CIRCUIT BREAKER BASED ON ANDROID", International Research Journal of Engineering and Technology, ISSN: 2395-0056 Volume: 07, Issue: 07, July 2020.
- [4] Vishal D. Kare, Sachin Kumar, Naveen "Ultra-Fast Acting Electronic Circuit Breaker", Third International Conference on Advances in Electrical, Electronics, Information, Communication and Bio-Informatics (AEEICB), Chennai, 2017.
- [5] Diarah Reuben Samuel, Egbune Dickson, OsukeChristian, "Microcontroller Based Code Locking System with Alarm", IOSR Journal of Electrical and Electronics Engineering (IOSR-JEEE), ISSN: 2278-1676,p- ISSN: 2320-3331, Volume 9, Issue 1 Ver. II (Jan. 2014)
- [6] R. E. Mueller, Pratik Yadav, Suraj B, "Temporary protective grounding of distribution circuits," in Proc. 21st Annu. North-Amer. Power Symp., 1989, pp. 270–280.
- [7] M. E. Valdes, "Adapting failure mode and effects analysis (FMEA) to select hazard mitigation measures," in Conf. Rec. 59th IEEE IAS Annu. Meeting PCIC, 2014
- [8] Guide for Safety in AC Substation Grounding, IEEE Std 80-2000, pp. 8, 11, and 26.
- [9] N. Nichols, D.D.Shipp "Designing to avoid hazardous transferred Earth potentials," IEEE Trans. Ind. Appl., vol. IA-18, no. 4, pp. 340 347, Jul. 1982.
- [10] Muhammad Ali Mazidi, "The 8051 Microcontroller and Embedded systems", Department of Computer Science and Information Engineering National Cheng Kung University, IEEE 2018.
- [11] Sebin J Olickal , "Electric line man safety system with one time password based circuit breaker", IRJET, Vol.4, No.3, April 2015.
- [12] Po-Chen, Vuk Malbasa, Mladen Kezunovie, "Sensitivity analysis of voltage sag based fault location algorithm", Power Systems Computation Conference (PSCC)2014, pp.1-7,2014.
- [13] National electrical safety code committee, accredited standards committee C2 rule 441-1 AClive work minimum approach distance (2002 edition, page-228) IR540
- [14] Mallikarjun Hudedmani "Password Based Distribution Panel and Circuit Breaker Operation for the Safety of Lineman during Maintenance Work",ISSN:2456-7108 Volume 1,Issue 1,pp.35-39,January 2017.
- [15] T.Arun Prasath, Suprabhat Bharti, B.Pavan Kumar, A.Harsha Vardhan, "Implementation of Protective Devices for Lineman Protection in Real Time Operation", International Journal of Innovative Technology and Exploring Engineering(IJITEE), ISSN: 2278-3075, Volume-9 Issue-2S2,December 2019.



10.22214/IJRASET



45.98



IMPACT FACTOR:  
7.129



IMPACT FACTOR:  
7.429



# INTERNATIONAL JOURNAL FOR RESEARCH

IN APPLIED SCIENCE & ENGINEERING TECHNOLOGY

Call : 08813907089  (24\*7 Support on Whatsapp)