



IJRASET

International Journal For Research in
Applied Science and Engineering Technology



INTERNATIONAL JOURNAL FOR RESEARCH

IN APPLIED SCIENCE & ENGINEERING TECHNOLOGY

Volume: 9 Issue: VII Month of publication: July 2021

DOI: <https://doi.org/10.22214/ijraset.2021.36544>

www.ijraset.com

Call:  08813907089

E-mail ID: ijraset@gmail.com

Ship Blast Analysis

E. Deepak Naidu¹, P. Eswar Sai Teja², A. Balaji³, S. Irfan⁴, A. Sai Kumar⁵

¹Assistant Professor, Dept. of Mechanical Engineering, DMS SVH College of engineering, Machilipatnam, India.

^{2, 3, 4, 5}-B.tech student, Dept. of Mechanical Engineering, DMS SVH College of engineering, Machilipatnam, India

Abstract: Naval vessels and Submarines structures in their fighting role are susceptible to explosion of torpedoes, mines, TNT etc. The damage inflicted by Contact explosion consists of direct shock wave damage to hull, whipping damage to keel and mechanical damage to onboard equipment and associated systems. The order to design a shock resistant structure, it is important to simulate these structures and loads and then subsequently analyze the same to predict the response (as performing experiments would be expensive). The TNT (Trinitrotoluene) explosion analysis of large structures like ships could be considered as one of the most complicated numerical analysis. Loads can be calculated by using published empirical formulas, which are complicated if calculated the large structure. By using of the FE Software ANSYS, backed up with in the developed software, for Explosion analysis of structures.

Keywords: Ship Explosion, Static Structure, Explicit Dynamics, Autodyn

I. INTRODUCTION

The surface ships might be attacked by weapons during the operation period; moreover, underwater explosion (UNDEX) will have significant wave shock and bubble oscillation on the bottom of the navy vessel which will have high impact on ship structure. The study of UNDEX on the navy ship was reported by Abbot ; afterward, the related tests and researches were studied before World War I. During WWI and WWII, intensive and significant efforts had been made on developing and optimizing surface ship structural design.



Underwater Explosion To Ship Surface

As, we have known that the high pressure from first shock wave has a direct severe influence on ship structure; nevertheless, even the pressure of the bubble oscillation is much smaller than the first shock wave, the ship hull beam can enter in resonance with the bubble oscillations, what is called whipping phenomenon. The importance of considering bubble pulsation dynamic when predicting by theoretical equations the whipping response of a ship hull submitted to underwater blast loads.

II. METHODS FOR BLAST PROCESS:

In this thesis, the explicit FE code ANSYS AUTODYN has been used in all simulations. Different approaches to describe the blast load are available, and the aim of this chapter is to briefly present an overview of some different modeling options. However, to describe how shock waves are commonly treated in numerical codes, followed by alternatives for reference frames used to describe material movement.

A. Shock

A shock front is very thin and therefore often approximated as a discontinuous change in flow properties. The shock front as usually thinner than a typical finite element length used in a problem of practical use. Shock-fitting techniques have been used in the past, where the energy jump in the Rankine-Hugoniot equation was treated as an inner boundary condition. Although this is a possible approach in one dimension, it would be complicated to implement in 3D, resulting in long computational times.

B. Ship Frame

A structure is generally most easily defined in a Lagrangian (material) reference frame, where the mesh follows the material movement. The drawback is when the element gets too distorted due to large deformations, which usually result in reduced accuracy, smaller time steps and possible solution failure. An alternative to the Lagrangian frame of reference is the Eulerian (spatial), where the mesh is fixed over a time step and the material is allowed to flow across the element boundaries. This method is suitable for describing the rapidly expanding gas flow from explosives, since no distortion of the mesh takes place.

C. Empirical Load Function

We knew that blast load is transient, it can be applied directly on predefined Lagrangian elements. A common empirical load function is Conwep, which is based on the extensive collection of blast data presented by Kingery and Bulmash, based on spherical or hemispherical shapes of TNT detonated in air. The Conwep load function has been implemented in ANSYS AUTODYN compared to experimental results using a cylindrical shaped explosive detonated in air. Numerical result is deviated to a large extent compared to the measured values, most likely due to the dissimilarity in charge shapes between the experiment and blast loading data. The procedure involves experiments with clamped steel plates subjected to uniform or localized blast loading, where the impulse is measured using a ballistic pendulum. In the corresponding numerical simulations, the measured impulse can be used to form the load directly applied on the Lagrangian elements describing the steel plate. The advantage of using empirical load functions is short calculation, since the blast load is predefined.

III. MATERIAL MODELS:

The material models used in this work for modelling the blast loading and the subsequent structural response are briefly described. The Air has been modeled using a perfect gas form of EOS. The high explosive elements initially contain the chemical energy, defined as an initial energy. The energy in the element can be released in two ways, assuming ideal detonation. One method is the programmed Numerical simulations of blast loaded steel plates for improved vehicle protection.

TNT material defined as trinitrotoluene. which TNT material is used as a high explosive for industrial and military. It's also an intermediate within the production of dyes and photographic chemicals. TNT stains the skin orange and yellow and is quickly absorbed through skin, especially when skin is moist. High exposures may cause weakness, headaches, liver, or central nervous system damage.

A. Space Claim

SpaceClaim is a solid modeling CAD software. SpaceClaim is developing 3D solid modeling software for mechanical engineering. The designing concepts are created by pulling, moving, filling, combining, and re-using 3D shapes. The total length of the ship is 95 m, its breadth is 40 m, and its draft is 4.75 m.

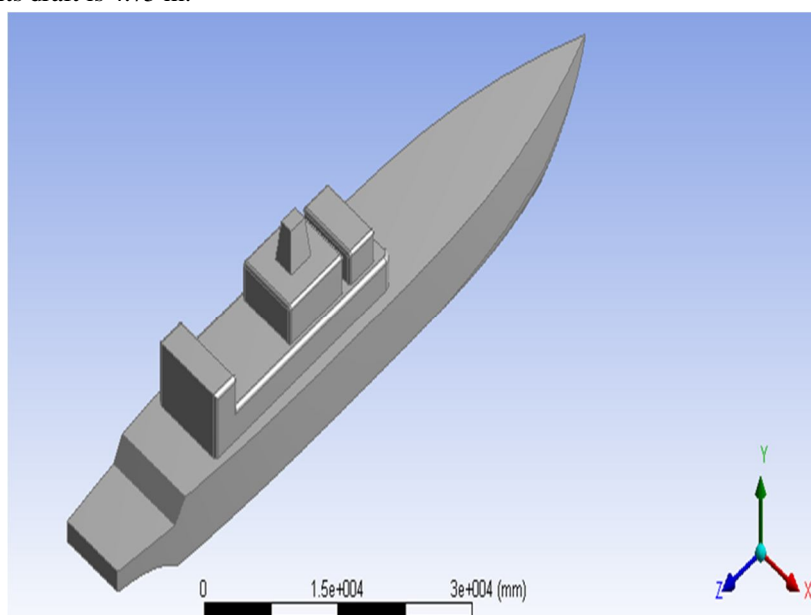

B. Meshing To Ship Structure

The meshing process to ship structure by finite element method is a numerical technique for solving problems which are described by partial differential equations or can be formulated as functional minimization. The domain of interest is representing as an assembly of finite elements. Finite elements are determined as nodal. A physical problematic values are transformed into a finite element problem with nodal values. For a linear problem a system of linear algebraic equations are solved. Values are calculated accurate because of the method we are using the finite element method.

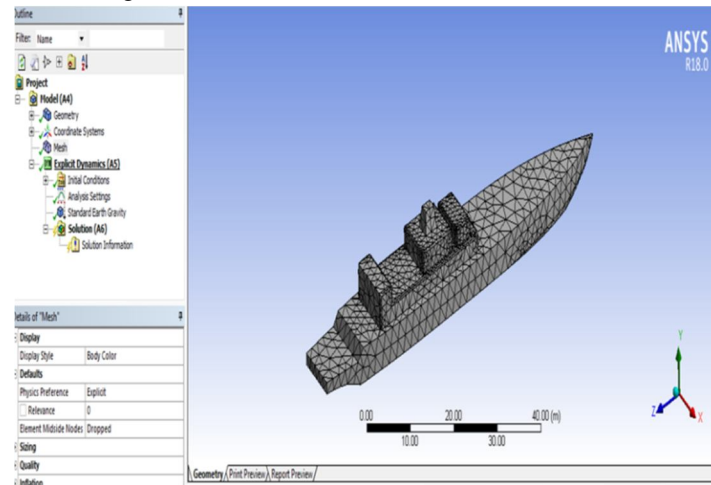

Transient Structural analysis is that the determination of the consequences of loads on physical structures and their components. Structures subject to this kind of analysis include all that possesses to face up to loads, like buildings, bridges, vehicles, furniture, attire, soil strata, prostheses and biological tissue. Structural analysis employs the fields of applied mechanics, materials science and applied mathematics to compute a structure's deformations, internal forces, stresses, support reactions, accelerations, and stability. The results of the analysis are wont to verify a structure's fitness to be used, often precluding physical tests. Structural analysis is thus a key a part of the engineering design of structures.

C. Explicit Dynamics

Explicit methods are more efficient and accurate for simulations involving shock wave propagation, large deformations and strains, non-linear material behavior, complex contact, fragmentation and non-linear buckling. This is introduction to performing explicit dynamic analysis for both experienced and new users. This is used for applying the earth gravity to ship structure on explicit.

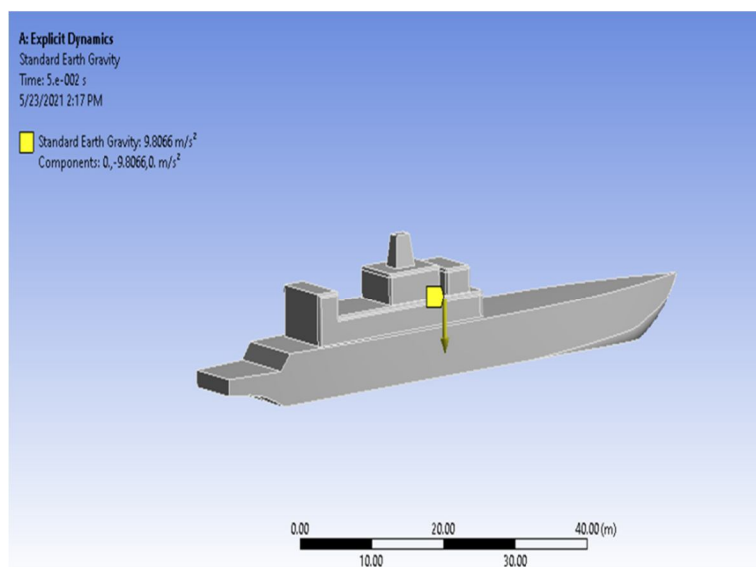

D. Ansys Autodyn

In today's operations, explosive blasts fragment and move as much material as possible, but the amount of explosive energy is constrained by budgets and limits on blast vibrations. The Autodyn solving the large material deformation, fluid/gas flows, blast conditions, and fragmentation of brittle materials.

By using this autodyn software, we create the region for the ship structure. So, the 3-D multi-material Euler part is created with the measurements of (30,000,40,000,60,000).

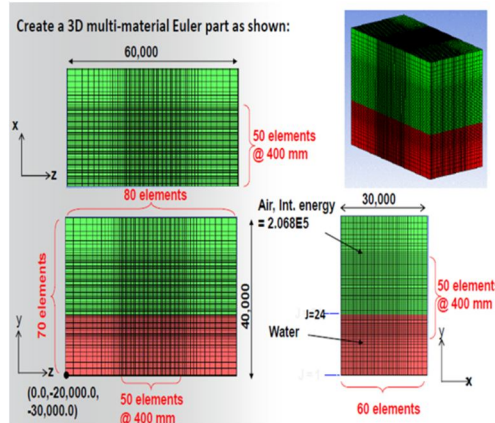

IV. RESULTS

A. Analysis Process And Results Static Structural

For obtaining a convincing and optimized ship design, static structural analysis was performed. Various impact loads such as uniformly distributed load by applying point mass, earth gravity fixed ship front and back due to the ship is floating on water surface in ANSYS software.

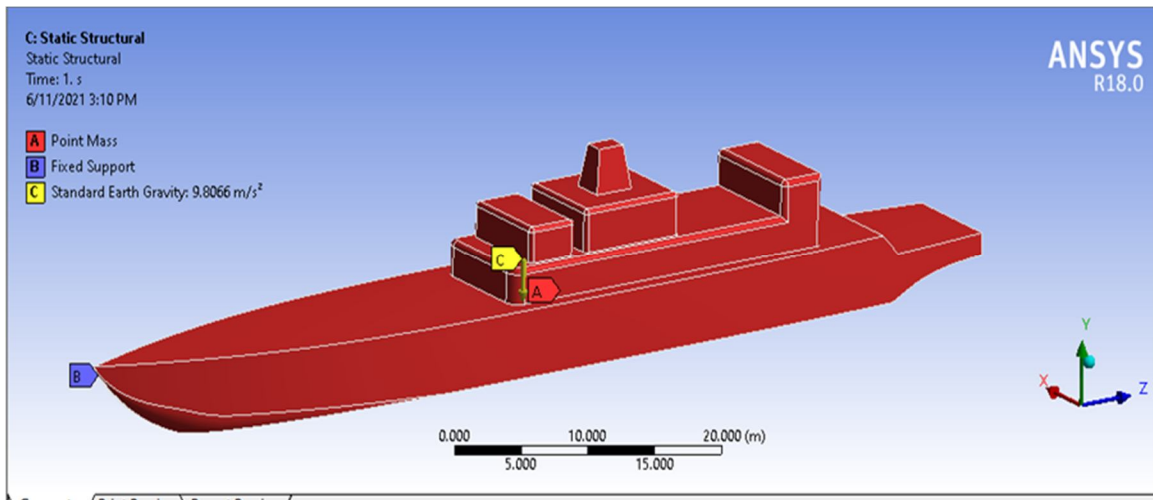

After static structural analysis was performed. Various impacts of ship such as total deformation & equivalent stress were calculated and the analysis was done in ANSYS software. At first, we apply load of 5 tons in the middle of ship in static analysis for finding the results shown below. After analyzing the results.

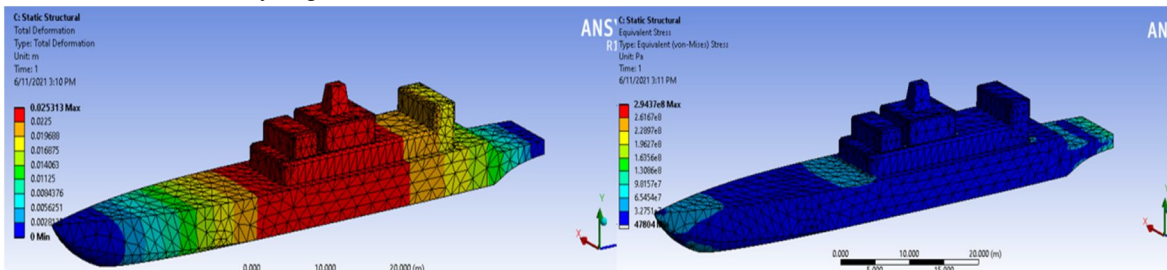

B. Analysis Process And Results Of Ship Blast

The limitation of ANSYS, it is necessary to apply reaction forces into nodes instead of pressure loads to shell element if we want to implement transient response analysis. Therefore, Results are retrieved from the static analysis. Since the charge is located below the midships section, reaction forces are more significant amidships as it is confirmed. Moreover, the free surface constraint is represented by green triangles where the pressure load is zero.

According to the distribution of reaction force curves, it is clear that the trends are like pressure loads distribution with the time evolution.

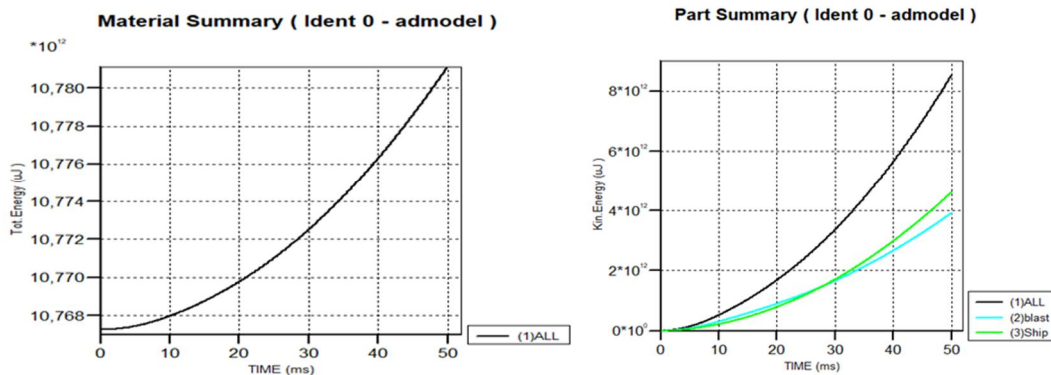

Although the results depicted seem to be more realistic regarding the displacement amplitudes as the one observed for the semi-cylinder, the same problem than the one encountered in the semi-cylinder study can be observed, that is the displacement is not zero at the initial time.

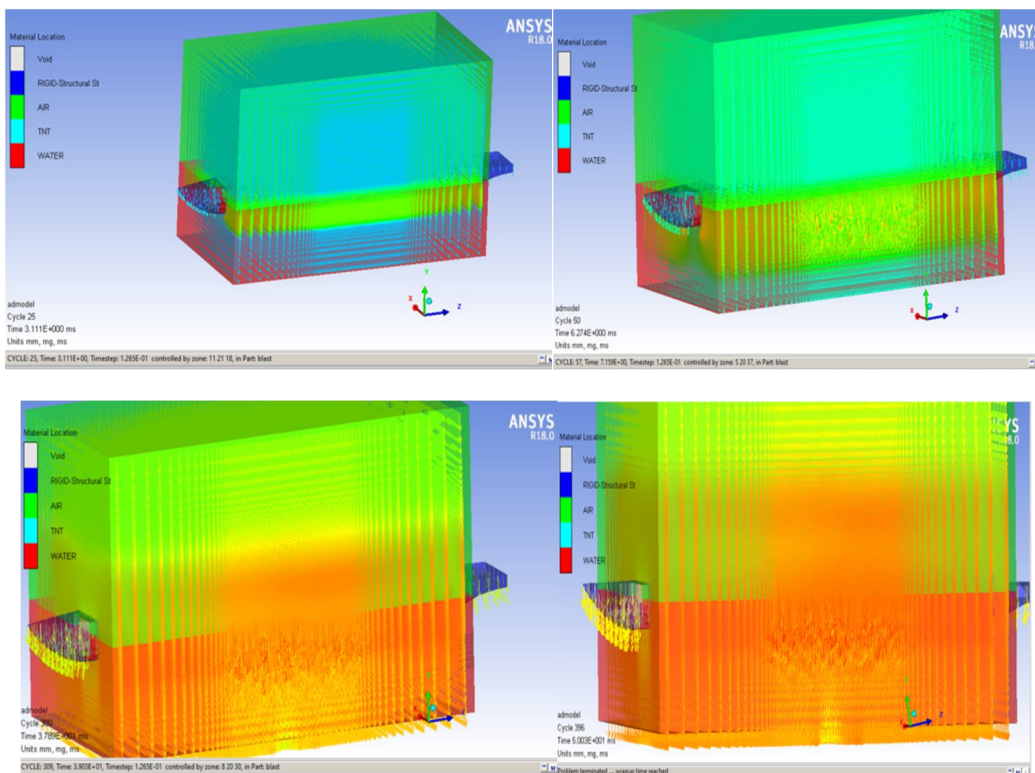

These cycles are analysis process, and we are taken time in explicit dynamics is 0.05 sec. At the time reach the 0.05 sec the last analysis fig show final result of explosion.

C. Velocity Graph

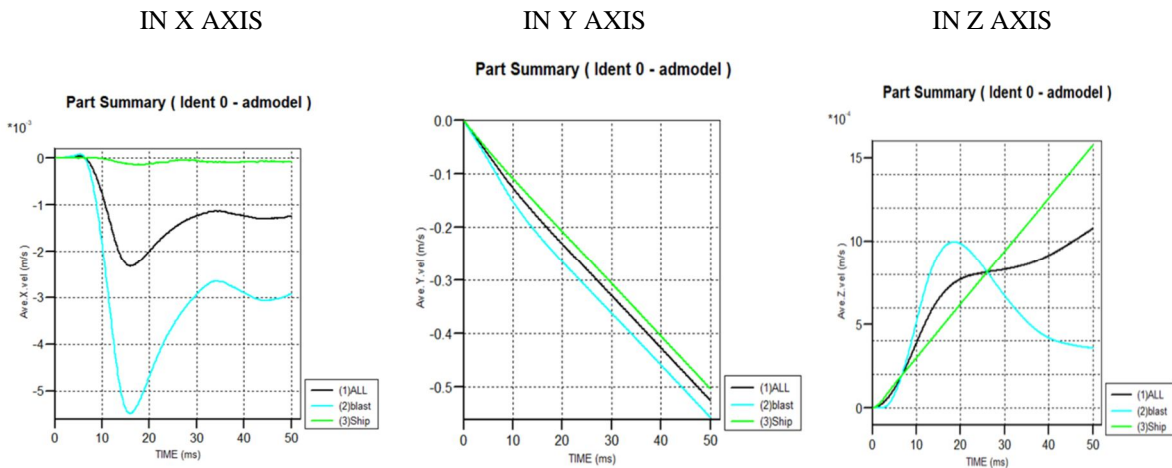

After observing the velocity graph , major impact show in Y,Z axis and X axis show's less impact in ship explosion on surface of water.

D. Momentum Graph

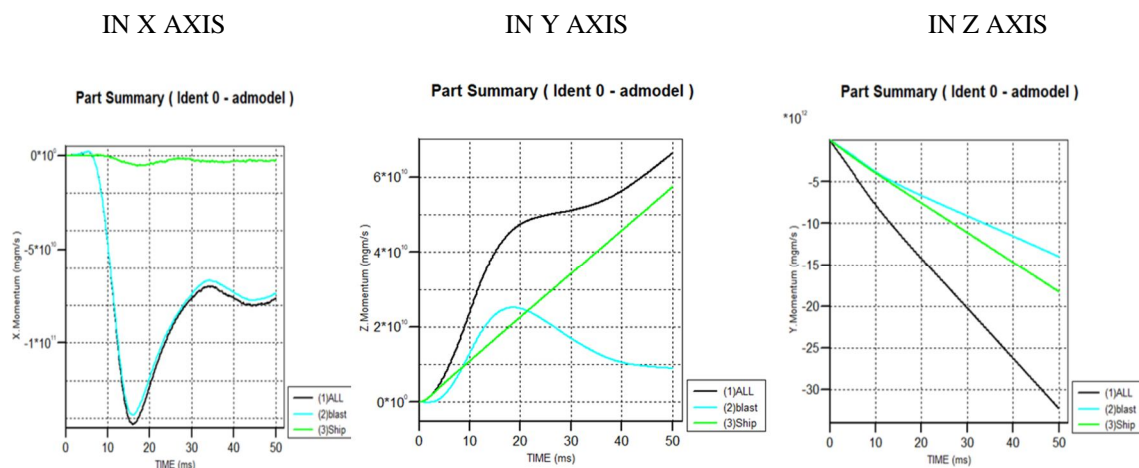

After observing the momentum graph , major impact show in Y,Z axis and X axis show's less impact in ship explosion on surface of water.

V. CONCLUSION

After analyzing the most important existing methodologies, it is the most suitable approach in order to predict the whipping response on ship structures submitted to the underwater explosion. In this study, a complete scheme is developed in order to perform the structure response by means of explicit and implicit numerical methods. The main conclusions drawn from the present research are summarized below:

According to pressure load distribution diagram gathered from ansys AUTODYN simulation, it is clear that the impulse I of first and second bubble which means that the energy is much higher during the bubble oscillation phase. Furthermore, the total energy diagram obtained from AUTODYN points out that the energy increases dramatically within secondary bubble pulsation phase; hence, it has been demonstrated that secondary bubble pulsation phase has the significant influence on ship structure.



REFERENCES

- [1] BRAND, C. L. (1945). Submarine Report -Depth Charge, Bomb, Mine, Torpedo and Gunfire Damage Including Losses in Action. Bureau of Ships Navy Department. Hydrographic Office,U.S.: VOLUME II.
- [2] Brett, J. M., & Yiannakopolous, G. (2007, May 3). A study of explosive effects in close proximity to a submerged cylinder. International Journal of Impact Engineering, pp. 206-225.
- [3] DeRuntz, J. A. (1989). The underwater shock analysis code and its applications. 60th Shock and Vibration Symposium.
- [4] Herring, C. (1941). Theory of the pulsations of the gas bubble produced by an underwater explosion. USA: United States Office of Scientific Research and Development.
- [5] Hollyer, R. S. (1959). Direct Shock-Wave Damage to Merchant Ships From Non Contact Underwater Explosions. Norfolk Naval Shipyard.
- [6] Hunter, K. S., & Geers, T. (2002). An integrated wave-effects model for an underwater explosion bubble. The Journal of the Acoustical Society of America, 1584-1601.
- [7] Hunter, K. S., & Geers, T. (2003). Pressure and velocity fields produced by an underwater explosion. The Journal of the Acoustical Society of America, 115, 1483-1496.
- [8] Hunter, K. S., & Geers, T. L. (2003). Pressure and velocity fields produced by an underwater explosion. The Journal of the Acoustical Society of America, 115



10.22214/IJRASET



45.98



IMPACT FACTOR:
7.129



IMPACT FACTOR:
7.429



INTERNATIONAL JOURNAL FOR RESEARCH

IN APPLIED SCIENCE & ENGINEERING TECHNOLOGY

Call : 08813907089  (24*7 Support on Whatsapp)