



IJRASET

International Journal For Research in
Applied Science and Engineering Technology



INTERNATIONAL JOURNAL FOR RESEARCH

IN APPLIED SCIENCE & ENGINEERING TECHNOLOGY

Volume: 9 Issue: VIII Month of publication: August 2021

DOI: <https://doi.org/10.22214/ijraset.2021.36644>

www.ijraset.com

Call:  08813907089

E-mail ID: ijraset@gmail.com

Buck and Boost Inverter

Dr. S. Ravi Chandran¹, Eerjala Srinu², Gammath Karthik³, Koturi Chiranjeevi⁴, Cheemala Praneeth Kumar⁵
^{1, 2, 3, 4, 5}Sreenidhi Institute Of Science and Technology

Abstract: A versatile operation of any electronic circuitry depends on the power source supplying the power for its operation. The buck converter is implemented using an integrated circuit(IC), LM317. The constructed buck converter was tested for load and line regulation cited in the datasheets for stability. The test and analysis for the linear buck converter was done using setup. The output measurements indicate that the power supply is functional. The measured output values results of the test circuit. The developed output power supply unit is important in measurements, laboratories and test setup. It is implemented for all general applications that require power supply unit.

XL6009 module is a DC to DC BUCK-BOOST converter module that operates at a switching frequency of 400kHz. In such high frequency, it provides smaller sized filter components compared with low frequency switching regulators. An improved Single-Stage Buck-Boost inverter is provided, using only three or four power semiconductor switches. The inverter can handle a wide range of dc input voltages and produce a fixed ac output voltage. The inverter is well suited to distributed power generation systems such as photovoltaic and wind power and fuel cells, for standalone or grid connected applications. The inverter has a single charge loop, a positive discharge loop and a negative discharge loop. In this complete design of the converter is carried out. This application report gives details regarding this conversion with examples.

I. INTRODUCTION

Switch-mode power conversion has been a pillar of modern electronics technology across many sectors including utility, industrial, commercial, and consumer markets for many years. In low-power DC/DC conversion applications, most modern power conversion is done with different types of power converters – Buck, Boost, and Buck-Boost Converters.

The controlled switch is turned on and off by using Pulse Width Modulation(PWM). PWM can be time based or frequency based. Time based Modulation is mostly used for DC-DC converters. It is simple to construct and use. The frequency remains constant in this type of PWM modulation. A buck and boost converter can supply a regulated DC output from a power source delivering a voltage below and above the regulated output voltage.

II. MOTIVATION FOR THE PRESENT RESEARCH WORK

With the day to day rise in technological evolution at its zenith, the emergence of new nanoscopic and microscopic electrical and electronic products continue to ensue and these products require DC source for their operation. Most of the existing power supply devices with various levels of complexities and sophistication has grasped the interest of researcher's and thus over the time has led many researcher to publish their work on power supply units. A stabilized variable power supply unit with a voltage range of 0.20v – 15.85v and current range of 0 – 3 Amps (45W) with a very low output impedance of 0.008 ohms has been developed and constructed in [1]. The study of regulation characteristics of a constructed power supply units to a certain load and line regulation has also been presented. The drawbacks of the circuit being the complexity of the circuit and the number of components are more with the addition of bridge rectifier circuit the losses tend to increase. Linear power supply unit have problems with efficiency and to increase and solve this problem a custom-made bipolar linear power supply with homemade pre-regulator circuitry is in series in front of power stage. Thus with constant VDS controlled pre-regulator, the power consumption can be reduced and efficiency can be increased

III. PROJECT OVERVIEW

In this paper, a linear buck converter with a variable input voltage and constant output voltage is designed and constructed for low input power applications like mobile charging and renewable energy applications. The proposed linear buck converter is built using LM317 voltage regulator, Boost Converter using XL6009 IC and inverter using SG3525. They are cost efficient, compact and light weight. The developed output power supply is much useful in measurements, laboratory works and general applications requiring DC power supply along with uses for power electronic devices such as mobile charging, research labs, electroplating, television and communication transmissions The hardware setup and simulation results with the PCB designs are presented in this paper.

A. Literature Review

The literature review indicates that there is a need for low cost, with high stability, low level of interference, ripple and noise level. The main aim is to develop a cost effective, compact, easy to design and develop power supply unit. This can be used for power electronic devices such as mobile charging, research labs, Electroplating, television and communication transmissions.

IV. DESIGN OF LINEAR BUCK CONVERTER USING LM317

The LM317 is a tuneable three-terminal voltage regulator with can provide more than 1.5Amps and an output voltage of 1.25 V to 37 V. represented in above figure 5.3. It requires only two external resistors for the output voltage. It has a line regulation of 0.01% and load regulation of 0.1%. Thus also includes a current limiting, thermal overload protection, and a safe operating area protection. Overload protection is functional even though adjust terminal is disconnected. Here a linear buck converter is designed and developed using the LM317 voltage regulator with a variable input voltage of 3-40V and constant output voltage of 5V. The produced output voltage is constant with very less ripple and the output voltage is always less than the input voltage. Even if the adjusting terminal is removed the overload protection remains.

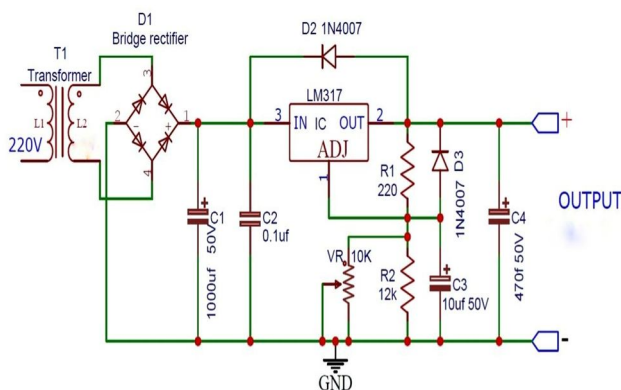

A. Design Specifications

V_{input}=3V to 40V.

V_{output}= 5V.

C1= 100µF/50V, C3= 10µF/16V, C4= 100µF (Electrolytic).

C2= C5 = 0.1µF/50V (Ceramic).

R1= 2.2K, 1/4W, 5%.

R2=220E, 1/4W, 5%.

R3=680E, 1/4W, 5%.

R5=470E, 1/4W, 5%.

LED1= Red, LED2= Green.

V. WORKING OF BUCK CONVERTER

The LM317 is a tuneable three-terminal voltage regulator with can provide more than 1.5Amps and an output voltage of 1.25 V to 37 V. represented in above figure 5.3. It requires only two external resistors for the output voltage. It has a line regulation of 0.01% and load regulation of 0.1%. Thus also includes a current limiting, thermal overload protection, and a safe operating area protection. Overload protection is functional even though adjust terminal is disconnected. Here a linear buck converter is designed and developed using the LM317 voltage regulator with a variable input voltage of 3-40V and constant output voltage of 5V. The produced output voltage is constant with very less ripple and the output voltage is always less than the input voltage. Even if the adjusting terminal is removed the overload protection remains. The below Figure 1 shows circuit diagram of linear buck converter using LM317. The above circuit consist of an LM317 three terminal voltage regulator with a variable input of 3-40V and a constant output of 5V. Here the LED's are used for indication purpose of the input and output. The input capacitor is used as smoothing capacitor and as input filter to improve the power factor and also to remove unwanted and undesired frequency or noise. The output capacitors here are used for improving the transient responses of the system. The two external resistors R2 and R3 are enough to set the output voltage.

VI. DESIGN OF BOOST CONVERTER

Boost Converter using XL6009 with Adjustable 3.3V to 12V Output Voltage. Buck & Boost regulator is made using two different topologies, as the name suggests, it consists of both buck and boost topology. We already know that Buck Regulator Topology provides a lower magnitude of output voltage than the input voltage, while a Boost Regulator Topology provides a higher magnitude of output voltage than the provided input voltage. We have already built a 12V to 5V Buck Converter and a 3.7V to 5V Boost converter Circuit using the popular MC34063. But at times, we might need a circuit that can both work as a buck and a boost regulator.

Say, for example, if your device is powered using a lithium battery, then the input voltage range will be between 3.6V to 4.2V. If this device needs two operating voltage 3.3V and 5V. Then you need to design a buck-boost regulator that will regulate the voltage from this lithium battery into 3.3V and 5V. So, in this tutorial, we will learn how to build a simple buck-boost regulator and test it on a breadboard for the ease of building. This regulator is designed to work with a 9V battery and can provide a wide output voltage ranging from 3.3V to 12V with a maximum output current of 4A.

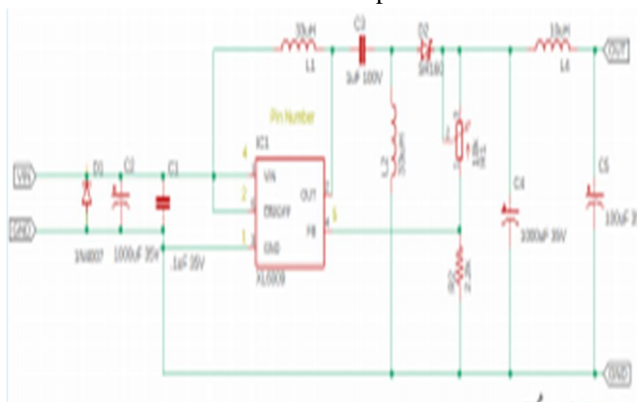

A. Design Specifications

- 1) XL6009
- 2) 10k preset
- 3) 33uH inductor - 2pcs
- 4) 1n4007 - 2pcs
- 5) SR160 - 1pc (for max 800mA output)
- 6) 10uH inductor
- 7) 100uF Capacitor
- 8) 1000uF capacitor -2pcs
- 9) 1uF ceramic or polyester film capacitor
- 10) 9V power source (battery or adapter)
- 11) Breadboard
- 12) Wires for breadboard.
- 13) UA747 IC

VII. WORKING OF BOOST CONVERTER

Boost Converter Construction and Working other than the Inductor, all the components should be available easily. The XL6009 IC is not breadboard friendly. Hence, I have used the dotted board to connect the pins of XL6009 to male header pins as shown below. Build the inductor as discussed earlier and create your circuit. I have used a breadboard to make things easy but a perf board is recommended. When the input voltage is higher than the set output voltage, the inductor gets charged up and resists any changes in the current path. When the switch gets off, the inductor provides the charged current via the C3 capacitor and finally rectified and smoothen out by the Schottky diode and capacitor C4 respectively. The driver checks the output voltage by the voltage divider and skips the switching cycle to sync the out voltage as per the feedback circuit output. The same thing happens during the boost mode when the input voltage is less than the output voltage and the inductor L2 gets charged up and provides the load current during switch off condition.

A. Testing of XL6009 Buck-Boost Converter Circuit

The circuit is tested in a breadboard. Do note that we have built the circuit on breadboard only for testing purposes and you are not supposed to load your circuit for more than 1.5A when on the breadboard. For higher current applications, soldering your circuit on perf board is highly recommended. To power the circuit, you can use a 9V battery but I have used my bench power supply which is set at 9V.

VIII. INVERTER USING SG3525

A single resistor between the CT and the discharge terminals provide a wide range of dead time adjustment. These devices also feature built-in soft-start circuitry with only an external timing capacitor required. A shutdown terminal controls both the soft-start circuitry and the output stages, providing instantaneous turn off through the PWM latch with pulsed shutdown, as well as soft-start recycle with longer shutdown commands. These functions are also controlled by an undervoltage lockout which keeps the outputs off and the soft-start capacitor discharged for sub-normal input voltages. This lockout circuitry includes approximately 500 mV of hysteresis for jitter-free operation. Another feature of these PWM circuits is a latch following the comparator. Once a PWM pulses has been terminated for any reason, the outputs will remain off for the duration of the period. The latch is reset with each clock pulse. The output stages are totem-pole designs capable of sourcing or sinking in excess of 200 mA. The SG3525A output stage features NOR logic, giving a LOW output for an OFF state.

SG3525 is used extensively in DC-DC converters, DC-AC inverters, home UPS systems, solar inverters, power supplies, battery chargers and numerous other applications. With proper understanding, you can soon start using SG3525 yourself in such applications or any other application really that demands PWM control.

IX. BLOCK DIAGRAM OF SG3525

SG3525 Block Diagram

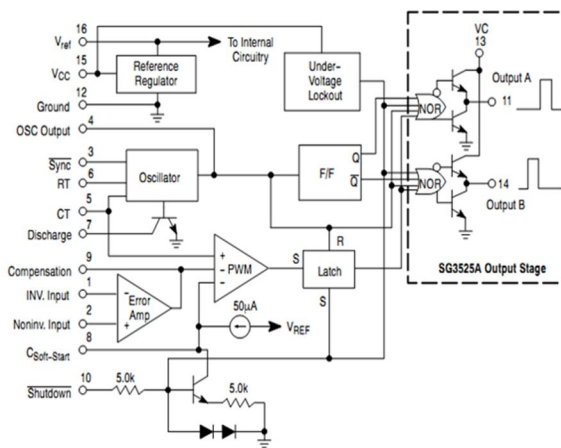

A. Circuit Design With SG3525 and Operation

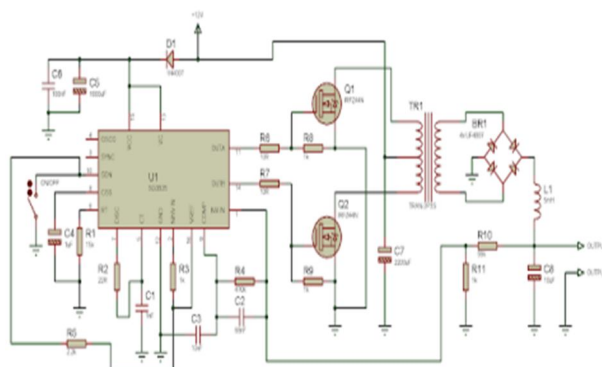

You can firstly see that the supply voltage has been provided and ground has been connected. Also notice that VC has been connected to VCC. I've added a bulk and a decoupling capacitor across the supply pins. The decoupling capacitor (0.1µF) should be placed as close to the SG3525 as possible. You should always use this in all your designs. Do not omit the bulk capacitor either, although you may use a smaller value.

Let's see pins 5, 6 and 7. I've added a small resistance RD (between pins 5 and 7) that provides a little deadtime. I've connected RT between pin 6 and ground and CT between pin 5 and ground. RD = 22Ω, CT = 1nF (Code: 102) and RT = 15kΩ. This gives an oscillator frequency of:

$$f = \frac{1}{10^{-9} * (0.7 * 15000 + 3 * 22)} \text{ Hz} = 94643.2 \text{ Hz} = 94.6 \text{ kHz}$$

As the oscillator frequency is 94.6kHz, the switching frequency is 0.5 * 94.6kHz = 47.3kHz and this is close enough to our target frequency of 50kHz. Now if you had needed 50kHz accurate, then the best way would have been to use a pot (variable resistor) in series with RT and adjust the pot, or to use a pot (variable resistor) as RT, although I prefer the first as it allows for fine tuning the frequency.

Let's look at pin 8 now. I've connected a 1µF capacitor from pin 8 to ground and this provides a small soft-start. I've avoided using too large a soft-start as the slow duty cycle increase (and thus the slow increase in voltage) causes problems when using CFLs at the output.

Let's look at pin 10 now. Initially it's pulled up to VREF with a pull-up resistor. So, PWM is disabled and does not run. However, when the switch is on, pin 10 is now at ground and so PWM is enabled. So, we've made use of the SG3525 shutdown option (via pin 10). Thus the switch acts like an on/off switch.

Pin 2 is connected to VREF and is thus at a potential of +5.1V (±1%). The output of the converter is connected to pin 1 through a voltage divider with resistances 56kΩ and 1kΩ. Voltage ratio is 57:1. At feedback "equilibrium", voltage at pin 1 is 5.1V as well as this is the target of the error amplifier – to adjust the duty cycle to adjust the voltage at pin 1 so that it is equal to that of pin 2. So, when voltage at pin 1 is 5.1V, voltage at output is 5.1V * 57 = 290.7V and this is close enough to our 290V target. If greater accuracy is required, one of the resistors can be either replaced with a pot or in series with a pot and the pot adjusted to give required reading. The parallel combination of the resistor and capacitor between pins 1 and 9 provides feedback compensation. I won't go into detail into feedback compensation as it is a vast topic on its own.

Pins 11 and 14 drive the MOSFETs. There are resistors in series with the gate to limit gate current. The resistors from gate-to source ensure that MOSFETs don't get accidentally turned on.

X. RESULTS

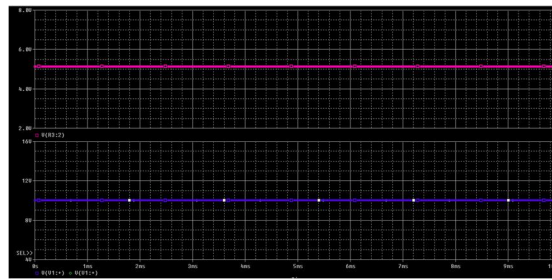

Vin=10V and Vout=5V

The above waveform shows the input voltage to the linear buck converter of 10V and the output voltage of 5V constant without any transients and ripple

XI. CONCLUSION

A linear Buck converters using LM317 has been designed and developed. Boost converter is designed using xl6009 converter. The linear buck converter has a variable input of 3V-40V and constant output of 5v. Boost converter is used to convert 9v input supply to 38v output dc. These converted output is fed to inverter input which powers output load. The designed power supply unit has ripple-free output, line regulation of 0.01% and load regulation of 0.1%. The device is simple to design and implement cost effective, compact and light weight as it uses very less components. It has less heat dissipation compared to other discrete devices. The linear buck converter type power supply unit is commonly used in applications like, test zig for defective component checking, HVAC, battery charging for mobile applications, research labs, Electroplating, television, communication transmissions and renewable energy applications.



REFERENCES

- [1] Adedayo Oke, Rabiu Jamiu Ariyo, Egunjobi Abiodun Isiaka, Akinnubi Rufus Timotheu, "Design and construction of a stabilize variable power supply unit" Innovative Systems Design and Engineering ISSN 2222-1727 (Paper) ISSN 2222-2871 (Online) Vol.5, No.6, 2014
- [2] Kuo-Bin Liu, Chen-Yao Liu and Jeng-Tzong Sheu, "High Efficiency Linear Power Supply with preregulator controlled by keeping constant RDS of MOSFET" Proceedings of the 1999 Particle Accelerator Conference, New York, 1999
- [3] Engr. Qazi Waqar Ali, Prof. M. Zahir Khan, "Simulation and Comparative Analysis of Linear DC Power Supply" Int. Journal of Engineering Research and Applications ISSN: 2248-9622, Vol. 3, Issue 6, Nov-Dec 2013, pp.1251-1256
- [4] P. Hari Krishna Prasad and Dr. M. Venu Gopal Rao, "Design of efficient low voltage high current dc to dc power supply" International Journal of Engineering Research and Applications (IJERA) ISSN: 2248-9622 Vol. 2, Issue 2, Mar-Apr 2012, pp.1565-1570
- [5] Jong- Mu Lee, Seung- Wook Hyun, Prof. Chung- Yuen Won, "High Efficiency Power Supply Unit For Server Power Application" International Conference on Electrical Machines and System (ICEMS) October 25-28 Pattaya City, Thailand.
- [6] Rich Nowakowski, Robert Taylor, "Linear versus switching regulator in industrial application with a 24V Bus" Analog Applications Journal, 3Q, 2013.
- [7] STAN2389: "An MCU-based low cost non-inverting buck-boost converter for battery chargers" Motorola Semiconductor. "Application note AN954: A Unique Converter Configuration provides step-up/down functions... a unique step-up/down configuration can be created ... which still employs a single inductor for the voltage transformation"



10.22214/IJRASET



45.98



IMPACT FACTOR:
7.129



IMPACT FACTOR:
7.429



INTERNATIONAL JOURNAL FOR RESEARCH

IN APPLIED SCIENCE & ENGINEERING TECHNOLOGY

Call : 08813907089  (24*7 Support on Whatsapp)