



IJRASET

International Journal For Research in
Applied Science and Engineering Technology



INTERNATIONAL JOURNAL FOR RESEARCH

IN APPLIED SCIENCE & ENGINEERING TECHNOLOGY

Volume: 9 Issue: VII Month of publication: July 2021

DOI: <https://doi.org/10.22214/ijraset.2021.36820>

www.ijraset.com

Call:  08813907089

E-mail ID: ijraset@gmail.com

Channel Coding Technique for 5G to Improve Flexibility

Annushree Kumari¹, Vinod Kumar Jadhav²
^{1, 2}MIT World Peace University, Pune, Maharashtra

Abstract: 5G wireless network will take place after 4G. It will create many new issues. Some problems like, communication with low BER, and performance might be severe issue. In this thesis, coding methods are proposed in order to decrease the signal loss during the transmission process of data. Also, the LDPC system is explained in order to get good results with lower bit error rate over 5G standards by trying to compare it with systems like, LDPC, Convolutional and Turbo code system. Finally, a framework is designed which is a combination of LDPC codes with polar codes in order to improve information transmission efficiency.

Keywords: 5G data transmission, Polar code, LDPC, OFDM, Millimeter-wave.

I. INTRODUCTION

A. The Advancement of Wireless Communication Technology

Wireless communication is definitely an emerging area, which has majorly improved the interaction between people. 1G technology was based on Analog signal but it had very low penetration level and it was highly exposed to noise from the environment leading it to be confined to a specified area. 2G was introduced with GSM. Voice communication was done with the help of digital signal. 2.5G was introduced for accessing data over the internet and it was known as GPRS but GPRS had a limitation. Its data rate was very low. The evolution of GSM was from 2G to 2.5G to 2.75G (EDGE), collectively known as 2G system. The data rate was not that good, so, 3G was introduced and known as UMTS (Universal Mobile telecommunications service). The data rate was increased. Next, 4G was introduced with a standard of stationary user giving a speed of 1Gbps and 100Mbps for user being in mobility. The researchers have started the research on the fifth generation (5G). They believe that 5G network can obtain more system capacity, high efficiency of data rates and more cell throughput.

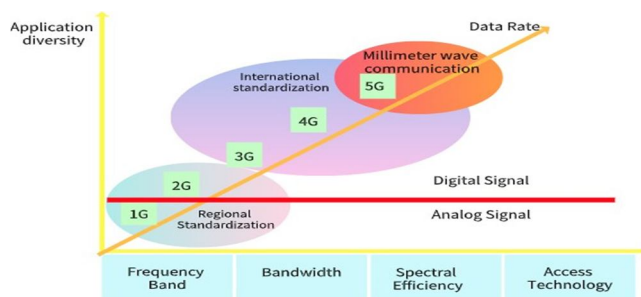

Fig. 1. Advancement of wireless communication systems

B. Literature Survey About 5G

The 5G includes QoS and data rate of futuristic applications. Fig.2 is the structure of 5G. 5G has 3 servers. With the help of these servers. 5G can make high resolution needed by cell phones. It can also provide considerable amount of bandwidth for wireless communication. The servers might be connected to several functions like CDMA, BDMA, FIP, cloud computing, Wi-max or LTE. The above functions will achieve a really high data speed for transmission. The researchers believed MIMO could also be supported by 5G. MIMO could reduce the error rate and increase the information rate relatively.



Fig.2. Framework of 5G

C. The Evolution of 5G

5G has become very crucial technology. After many years of evolution, the technology of 5G can provide high resolution. It can hand thousand times more traffic and faster than 4G. It has become the foundation of virtual reality, IOT, etc. The technologies emerging as the foundation of 5G are millimeter-waves, small cells, massive MIMO, beam forming and full duplex. Latency means the end-to-end delay in communication, the time measurement between sending and response of a piece of information. Low delays can be obtained by the advancement of 5G based networks. For ideal cases, the latency is below milliseconds. As the popularity of 5G is increasing, the spectrum demand is becoming more complicated. Various application and services require individual spectrum bands having various characteristics. They require both, high and low frequency bands. This, it is a limited resource and the sharing of spectrum is necessary. MIMO is an important technology in 5G. MIMO system gains high speed of transmission without taking any extra spectrum and power. In addition, the MIMO-antenna can improve the standard of communication.

D. Challenges in Data Transmission in 5G

Theoretically, the frequency of signal of 5G is high due to millimeter-wave technology. While comparing it to 4G LTE, the frequency can be expanded up to 300GHz. Due to this, the data transmission cost is high. High frequency, allowing the signal to gather more information and accumulate more frequency sources, makes interference of the signals with the weather conditions easy.

II. TECHNIQUES IN 5G

A. 5G NR

It is the global standard for new 5G wireless interface. It makes the connection faster, better, more efficient and enables the connectivity to connect with the world around us. It provides a uniform network connectivity to meet the connectivity needs. It supports diverse spectrum, diverse services and devices and diverse deployments. 5G NR delivers optimized waveforms and multiple access techniques, heavily leveraging the inherited advantages of the OFDM. Scalable numerology will address different spectrum types, spectrum band and deployment models. Scalable time intervals will support extreme variations in latency. A flexible frame structure will efficiently multiplex services and features, to adapt to future cases and support traffic puncturing for mission critical transmissions. A new self-contained, integrated design will lower latency and also provide built-in flexibility for new deployments and future services. 5G NR will also incorporate advanced wireless technologies such as massive MIMO and mobilizing millimeter-wave.

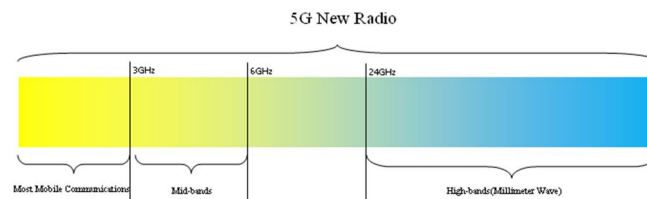

Fig. 3. Spectral bands of 5G NR

B. OFDM

Multiple access scheme for the 5G is a combination of Orthogonal Frequency Multiple Access and Time Division Multiple Access. Multiple access is for the separation of resources for users in the cell. Cyclic prefix OFDM is used in 5G. OFDM uses IFFT for modulation and FFT for demodulation. It has the lowest complexity and has more application in the method of multi-carrier transmission. Fig. 4 shows the structure of OFDM. The elements are transmitted in a sequence to a specified frequency and then sent out. OFDM divides the sequence to sub-sequences, modulating them and finally transmitting them. Thus, the four frequencies at the output satisfy the orthogonality between the two.

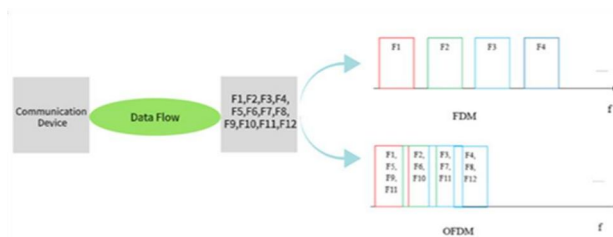

Fig. 4. Structure of OFDM

C. MIMO

In 4G, we have used conventional MIMO. Multi-user MIMO has more advantages over conventional MIMO technology. It works with cheap single antenna terminals as it creates a rich scattering environment. Resource allocation is simplified in MIMO as every active terminal utilizes all the frequency bits. MIMO provides more bandwidth to the user. uRLLC requires very low delay of information transmitted over the area. At higher frequencies, same amount of data can be transmitted in a small amount of time compared to lower frequencies. In 4G, the minimum transmission time is 1 millisecond for a specific amount of data and in 4G and 5G, that 1 millisecond is known as the sub frame time. The latency is reduced for quicker delivery of information. mMTC has massive amounts of devices running on low power in using smaller amounts of data and small transmission times. Carrier separation allows us to better share the information and provide for all different types of devices, enabling lots of devices to transmit in short bursts with a larger carrier separation. MIMO can focus on a specific device at a distinct location and deliver the data needed.

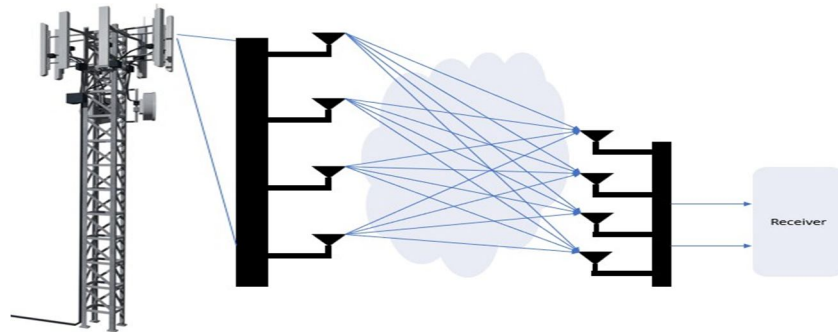

Fig. 5. Structure of OFDM

D. Millimeter-Wave

Millimeter-wave band uses high frequency signals which is an important characteristic feature of 5G wireless technology. Huge amounts of spectrums are unused at high frequencies. This allows frequencies for allocation of more bandwidth, which would result to faster and high quality content. Many channel issues need to be overcome. These signals are vulnerable to being blocked by buildings and structures, making intelligent beam forming and beam tracking necessary for 5G.

E. Coding Methods

5G NR uses various methods like LDPC code and Polar codes.

1) *LDPC Code*: LDPC codes have entered the field of communication research. As compared to turbo codes, LDPC has a good performance in peak and efficiency throughput. It has low complexity in decoding and it can gain low latency that is an essential standard for 5G as it uses specific bits. The code words have same set of distances resulting to minimum distance between two code words. The efficiency of LDPC is found in the decoding algorithm. It can check its parity operators of every number. The position will be flipped if most of them are contradicted. The above process is repeated until all the bits are unchanged. The probability of all the bits is calculated. Iteration is done until it reaches an unchanged position. LDPC coding process is shown in figure 6. Block converts uncoded signal to various smaller blocks which are easy for decoding. This method encodes small blocks at high speed. CRC encoder is used to detect error and reduce the probability of error. During the transmission, the Systematic Bit Priority Interleaver increases the code gain as it eliminates correlation of the bits. If we compare it with turbo coding this system has less waiting time and low complexity while decoding.

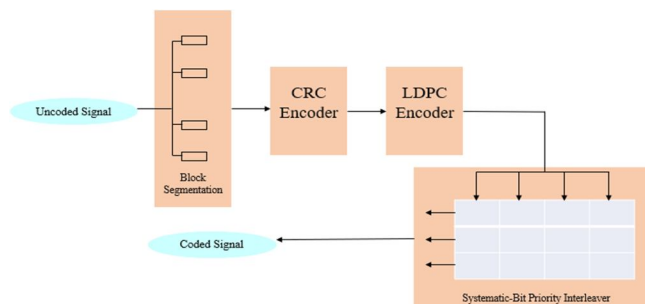

Fig. 6. LDPC Coding Process

- 2) **Polar Code:** 4G LTE uses tail biting convolutional code in its control channel and 5G uses this code in control channel as it has good encoding and decoding algorithm and high reliability. Code is established on channel polarization theory and it is based on linear block code. Polar codes reach the Shannon limit. The core theory is known as channel polarization and it includes channel combination and channel decomposition. As we increase the coding block size to be large enough, polar code technic acquires theoretical Shannon limit capacity. If the coding block is very small then the coding performance, cyclic redundancy, polar coding and interference cancelation decoder can exceed Turbo or LDPC.
- 3) **Turbo Code:** This code uses a blend of previous codes. Initially, the research was based on its decoding algorithm, coding structure and boundary of its performance. After development, the turbo code is close to Shannon’s theoretical limit as it has good random coding. Recently turbo code focuses on coding and decoding, analysis and designing and blend of codes and communication technologies. The main reason for not using turbo code in 5G technology, the maximum rate of turbo code is limited to 1Gbps in 4G. The decoding of convolutional code is done in an iterative manner. Turbo code decoding is more complex than conventional convolutional code. The complexity is due to the algorithm itself and not iterative process of decoding. LDPC decoder is a parallel internal structure and can handle large data, thereby reducing process delay.
- 4) **Convolutional code:** It is a memory corrected error code. Figure 7 shows structure of convolutional code and it is from the work of Goldsmith. It encodes k bits of information to n bits. The symbols that are encoded are related to the current k information that are taken as input and the initial L .

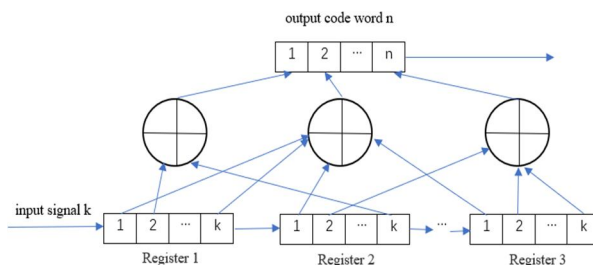

Fig.7. Convolutional Code

III. EXPERIMENT

A. Selection of Coding Method

As a channel model, Additive White Gaussian Noise (AWGN) is selected. The AWGN power spectral density not only follows uniform distribution, but the amplitude distribution also follows Gaussian distribution. AWGN is statistically independent between random variables at any two moments. The input signal and code rate determines the size of FFT.

- 1) **LDPC coded OFDM:** AWGN are channel model as it represents the channel noise characteristics. The coding part of LDPC is the input to the signal. QPSK is the modulation method and encoded signal blocks enters this part. iFFT is used to convert from frequency to time domain. At the receiving end the signal is brought back by FFT. As the propagation process continues, AWGN is used as the channel. Received signal enters the QPSK demodulation and the initial signal is received at the output.

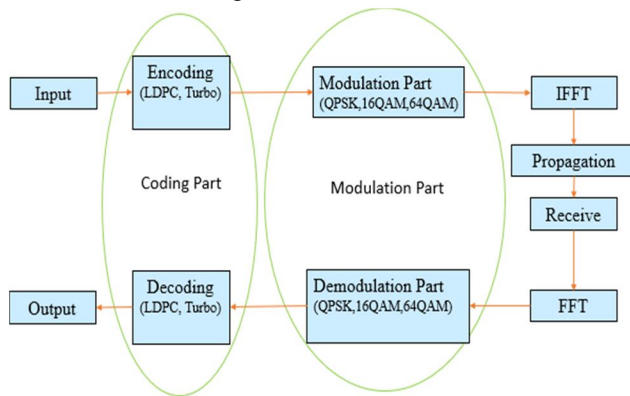

Fig.8. LDPC coded OFDM system

2) *Polar Codes*: The uplink contains parity check encoder and segmentation block. CRC interleaver exists in downlink. The CRC encoder as well as polar encoding is a part of the coding system. Rate matcher makes coded bits in an order so that it enters sub-block interleaver and change the size of the signal for transmission. Polar code builds a scenario so the transmitter is aware of channel state and generator matrix generates the code. Polarization code depends on the phenomena of channel polarization in order to transmit the message bit on sub channel and also the transmission of frozen bits. Figure 9 shows the NR Polar coding system.

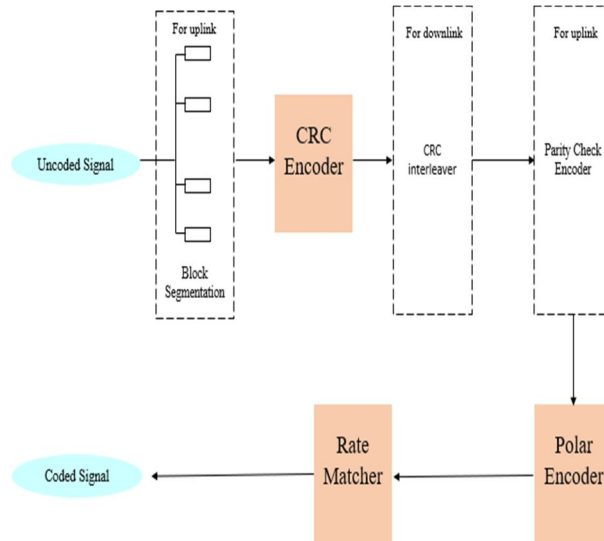

Fig.9. NR Polar Coding System

3) *Polar and LDPC Cascading System*: This section contains LDPC and Polar cascading system. When the SNR is high, BER performance improvement is not evident. For better transmission, combination of methods is used by various researchers. Figure 10 shows the proposed system architecture for the experiment.

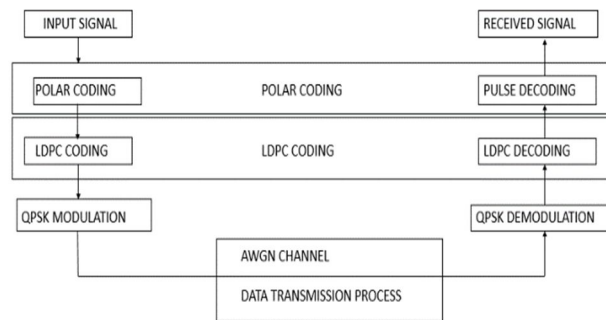

Fig.9. NR Polar Coding System

B. Selection of Modulation Method

Selection of a modulation method is very essential. Experimentation is performed on QPSK and QAM. QPSK and QAM, both are modulation techniques while QPSK uses different phase difference of the carrier signal as input. The four phases are 45°, 135°, 225°, 315° and the input is binary digits. QAM uses two independent baseband signals to terminate adjacent carrier frequencies. High protection is not required if the quality of channel is good. The chosen method is QAM because it has more efficiency as compare to QPSK but low fault tolerance. The SNR increases for QPSK indicating QPSK to be suitable for low communication environment as it can reduce BER whereas QAM for better communication environment. The performance of QPSK is lowest BER as compared to QAM over SNR between 10dB to 30dB. Thus, QPSK is the suitable modulation method. The experimental results can be seen in figure 8a and figure 8b.

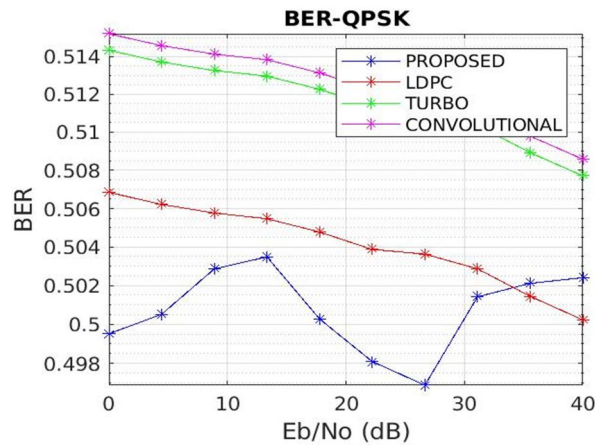

Fig. 8.a. Comparison of various Coding methods with QPSK modulation

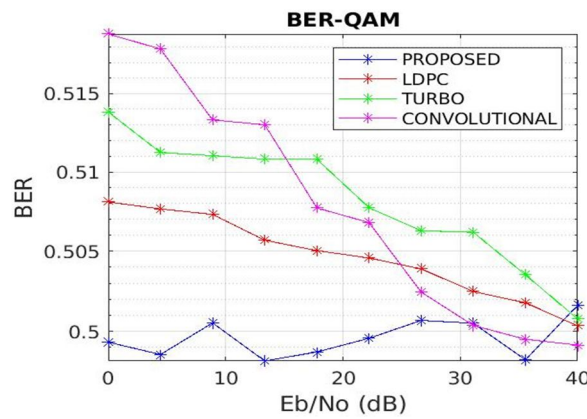

Fig. 8.b. Comparison of coding methods with QAM modulation

IV. RESULTS

A. Block Error Ratio

A Block Error Ratio is defined as the ratio of the number of erroneous blocks received to the total number of blocks sent. An erroneous block is defined as a Transport Block, the cyclic redundancy check (CRC) of which is wrong. Figure 9 shows the variation in BLER between the traditional system and the proposed system. As SNR increases, the decrease of BLER of the proposed system is more than the traditional system.

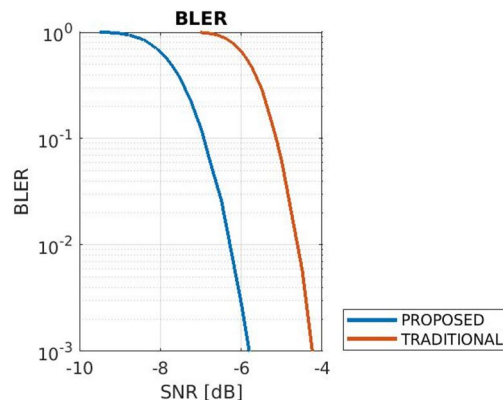

Fig. 9. BLER variation in the proposed system and traditional system

B. Throughput

The quantity of data which is successfully transmitted over a communication channel is known as throughput. Figure 10 shows the increase in throughput as the SNR increases. This shows that as the SNR increases, the data transmitted over the channel of the proposed system also increases, resulting to successful transmission of data.

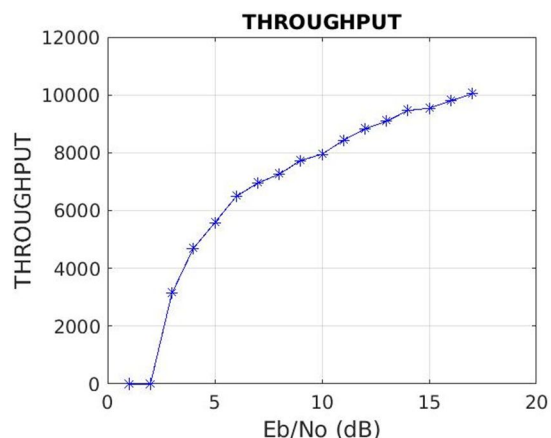

Fig. 10. Throughput vs SNR

C. Error Rate

The total number of errors received in a time period during the transmission of data is called error rate. Figure 11 shows that the error rate of the proposed system decreases while increasing the SNR, making the system efficient for transmission over the network.

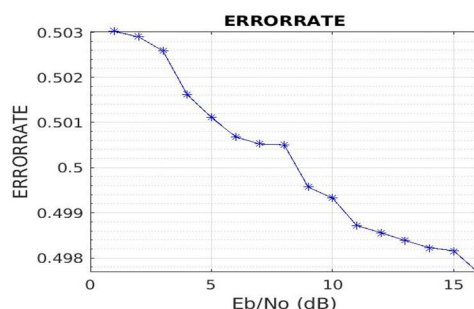

Fig. 11. Error rate vs SNR

V. CONCLUSION

In this thesis, we put forward various technique of 5G wireless communication like MIMO, millimeter-wave and OFDM. Coding methods and modulation technique were introduced. Various experiment were proposed and to find the best modulation technique, QPSK and QAM was analyzed. Comparison was done between various codes and system was designed which was a combination of polar codes with LDPC codes for better performance of BER.

REFERENCES

- [1] PANG Xingdong, HONG Wei, YANG Tianyang, LI Linsheng, "Design and Implementation of An Active Multibeam Antenna System with 64 RF Channels and 256 Antenna Elements for Massive MIMO Application in 5G Wireless Communications," China Communications, Pages: 16 – 23, 2014.
- [2] Cheng-Xiang Wang, Fourat Haider, Xiqi Gao, et al, "Cellular Architecture and Key Technologies for 5G Wireless Communication Networks," IEEE Communications Magazine, vol.52, no.2, pp. 122-130, Feb 2014.
- [3] Fagbohun, O. (2014). "Comparative studies on 3G, 4G and 5G wireless technology", IOSR Journal of Electronics and Communication Engineering, 9(3), 88-94, 2014.
- [4] Xiuhua, Q., Chuanhui, C., & Li, W. (2008, June). "A study of some keytechnologies of 4G system. In Industrial Electronics and Applications,2008". ICIEA 2008. 3rd IEEE Conference on (pp. 2292- 2295). 2008.
- [5] Aiash, M., Mapp, G., Lasebae, A., & Phan, R. (2010, May). "Providingsecurity in 4G systems: unveiling the challenges". In Telecommunications (AICT), Sixth Advanced International Conference on (pp. 439-444). 2010.
- [6] J. Zhang, X.H. Ge, Q. Li, M. Guizani, and Y.X. Zhang. "5G Millimeter wave antenna array: design and challenges," IEEE Wireless Commun. pp.106-112,



April 2017.

- [7] John Edwards, "5G versus 4G: How speed, latency and applications support differ". [Online]. Available: <https://www.networkworld.com/article/3330603/5g-versus-4g-how-speed-latency-and-application-support-differ.html>.
- [8] Bikos, A. N., & Sklavos, N. (2013). "LTE/SAE security issues on 4G wireless networks. Security & Privacy", IEEE, 11(2), 55-62, 2013.
- [9] Zhaoliang Chen, Wen Geyi, Ming Zhang, and Jun Wang, "A Study of Antenna System for High Order MIMO Device" [Online]. Available: <https://www.hindawi.com/journals/ijap/2016/1936797/>.
- [10] T. S. Rappaport et al., "Millimeter wave mobile communications for 5G cellular: It will work!" IEEE Access, vol. 1, pp. 335–349, May 2013.
- [11] Mobilizing 5G NR Millimeter Wave: Network Coverage Simulation Studies for Global Cities. [Online]. Available: <https://www.qualcomm.com/media/documents/files/white-paper-5g-nr-millimeter-wave-network-coverage-simulation.pdf>.
- [12] Binqi Yang, Zhiqiang Yu, Member, IEEE, Ji Lan, Ruoqiao Zhang, Jianyi Zhou, Member, IEEE, and Wei Hong, Fellow, IEEE. "Digital Beamforming-Based Massive MIMO Transceiver for 5G Millimeter-Wave Communications". IEEE Transactions on Microwave Theory and Techniques, vol. 66, no.7, July 2018.
- [13] Sadineni Sivakrishna, Ravi Sekhar Yarrabothu. "Design and Simulation Of 5G Massive MIMO Kernel Algorithm on SIMD Vector Processor". Conference on Signal Processing and Communication Engineering Systems (SPACES), on (pp. 53 - 57). 2018.
- [14] Yasunori Suzuki, Kunihiro Kawai, Hiroshi Okazaki, Shoichi Narahashi, Takahiro Asai, Yukihiko Okumura. "Requirements of Millimeter-Wave-Band Transmitter for Massive MIMO Base Station". IEEE MTT-S International Microwave and RF Conference (IMaRC) on (pp. 1 - 5). 2017.
- [15] R. G. Gallager, Low Density Parity-Check Codes. Cambridge, MA: MIT Press, 1963
- [16] Dennis Hui, Sara Sandberg, Yufei Blankenship, Mattias Andersson, and Leefke Grosjean. "Channel Coding in 5G New Radio". IEEE Vehicular Technology Magazine on (pp. 60 - 69). 2018.
- [17] Verizon 5g Technology Forum, Venison 5th Generation Radio Access;" Test Plan release 1,2017
- [18] 3GPP. (2018). Multiplexing and channel coding. 3rd Generation Partnership Project. Sophia Antipoli, France. TS 38.212, v15.0.0, Release 15. [Online]. Available: http://www.3gpp.org/ftp/Specs/archive/38_series/38.212/38212-f20.zip.
- [19] B. Liu, Y. Li, B. Rong, L. Gui, and Y. Wu, "LDPC-RS product codes for digital terrestrial broadcasting transmission system," IEEE Transactions on Broadcasting, vol. 60, no. 1, pp. 38–49, Mar. 2014.
- [20] Y. Zhang, A. Liu, C. Gong, G. Yang, and S. Yang, "Polar-LDPC concatenated coding for the AWGN wiretap channel," IEEE Communications Letters, vol. 18, no. 10, pp. 1683–1686, Oct. 2014.



10.22214/IJRASET



45.98



IMPACT FACTOR:
7.129



IMPACT FACTOR:
7.429



INTERNATIONAL JOURNAL FOR RESEARCH

IN APPLIED SCIENCE & ENGINEERING TECHNOLOGY

Call : 08813907089  (24*7 Support on Whatsapp)