



IJRASET

International Journal For Research in
Applied Science and Engineering Technology



INTERNATIONAL JOURNAL FOR RESEARCH

IN APPLIED SCIENCE & ENGINEERING TECHNOLOGY

Volume: 9 Issue: VII Month of publication: July 2021

DOI: <https://doi.org/10.22214/ijraset.2021.37210>

www.ijraset.com

Call:  08813907089

E-mail ID: ijraset@gmail.com

Design and Implementation of Multilevel Inverter with Various MPPT Algorithms for Optimal Tracking of PV System

Akash Gortyal¹, Sushil Karvekar², Rushikesh Lokhande³

¹PG Student, Department of Electrical Engineering (MTech Control System)

²Assistance Professor, Department of Electrical Engineering, Walchand College of Engineering, Sangli-416415, India.

³PG Student, Department of Electrical Engineering (MTech Control System)

Abstract: In this paper the different algorithm is performed in MATLAB Simulink to extract large amounts of energy from the pv system. MPPT algorithm is used to reduce complexity and to get better results, we used to perturb and observation, incremental conductance and fuzzy logic algorithm. A three-phase NPC inverter is used to connect the PV array with grid system, The PWM control method is used for the producing the PWM inverter signals. it contains PV array, dc / dc boost, three level NPC inverter. To get the synchronization between PV system and grid the synchronous reference frame theory with PLL block is used. The SRF theory will transform the three phase load currents (i_a , i_b , i_c) to the two instantaneous active (i_d) and reactive (i_q) components. The MATLAB simulation is preformed and we get a constant high output voltage from low input voltage and by changing the irradiance and temperature.

Keywords: Solar Photovoltaic System, Maximum Power Point, Neutral Point inverter, SRF theory.

I. INTRODUCTION

The power of PV system with one or more photovoltaic system is depends on temperature, irradiance and current which is drawn from the cell. PV generation will play a important role as solar based renewable source, but to get high efficiency from the PV system the PV mismatch is and important issue due to different temperature irradiance and aging of a PV panel so maximum power of each of the PV panel will be varies due to the above problem so for mismatch the individual panel require a high point of tracking and control is required [1]. Solar power system with inverter it converts dc power from pv modules into alternating current and then supplies to the public network. If the disturbance occurs at DC side during the voltage adjusting that may leads to over or under voltage so to get a good performance of DC voltage control will directly contributes the performance of MPPT. The multilevel inverter is used in order to implement to grid system, there is a solution to the solar-energy applications, such as a photovoltaic (pv) array, directly related to each level of the inverter, and the NPC topology has advantage like DC- link capacitors are common to three phase uses to reduce the total inverter losses and the over voltage across the switches. The multilevel inverter is connected to Grid with interconnection of PV system. The PV system connected together with grid by using boost converter and multilevel inverter with MPPT for control of grid system. The DC power which is generated using PV panels has to transform into ac using dc/ac inverters and dc/dc boost converter for the connection with an AC grid.

The organization of this paper is in section II the design of photovoltaic array is described, in section III different MPPT algorithms is discussed, in section IV the design of boost converter, in section V Neutral point clamped inverter with pulse width modulation is described, in section VI synchronous reference theory is explained, in section VII the simulation model and results is described, in section VIII the conclusion is discussed.

II. SOLAR PHOTOVOLTIC SYSTEM

The PV array can be connected together either series or parallel, but we use generally series connected to get the increased voltage from PV panel and the current will be same. if the panel Is partially shaded it will not produce the same amount of current, but the performance of PV arrays is rated according to maximum DC power [7]. Solar cells can be designed as a current source in antiparallel with diode shown in Fig. 1 A direct current is made when the cell is illuminated by light, which varies in proportion to the solar energy.

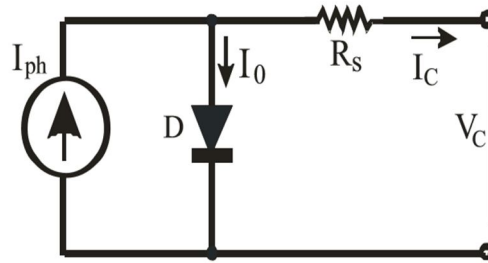

Fig.1. PV Array Circuit

$$V_c = \frac{AKT_c}{e} \ln \left(\frac{I_{ph} + I_0 - I_c}{I_0} \right) - R_s I_c$$

From the equation PV output voltage (V_c) above the performance of the photovoltaic current is determined by the load current which depends on the sun's rays and the temperature.

III. MAXIMUM POWER POINT TRACKING

MPPT is desirable, to operate the at maximum efficiency, this technique will maximize power that comes from the PV array, When the pv system is connected to power conditional unit, so we can say that maximizing pv power that is the output power of the load increases, vice versa if the output power gets maximize of power conditional unit, then automatically PV power also increases [3].

A. Perturb and Observation Method

The P&O method used to trace MPP. In this method, a small perturbation is introduced, which allows for a change in the power output of the PV module. From the flowchart shown in fig.2 we can see the first step is to measure the present voltage $v(k)$ and present current $i(k)$ and past voltage $v(k-1)$ and past current $i(k-1)$ after measuring the two parameters. we calculate the change in power. If there is a change of power (dp) is equal to zero the we get the output voltage as the same. but if the change in power is grater, then zero it checks further that is if change is power is grater, then zero is True the it checks the change in voltage, if the change in voltage is grater the zero is True then the output power decreases with the dV . if the change in voltage is not a grater, then zero then the output voltage is increased by the dV . if the change in power is not a grater, then zero, if the change in voltage is less than zero is true then the output power decreases with dV . if the change in voltage is not less than zero then the output voltage is increased by the Dv [2].

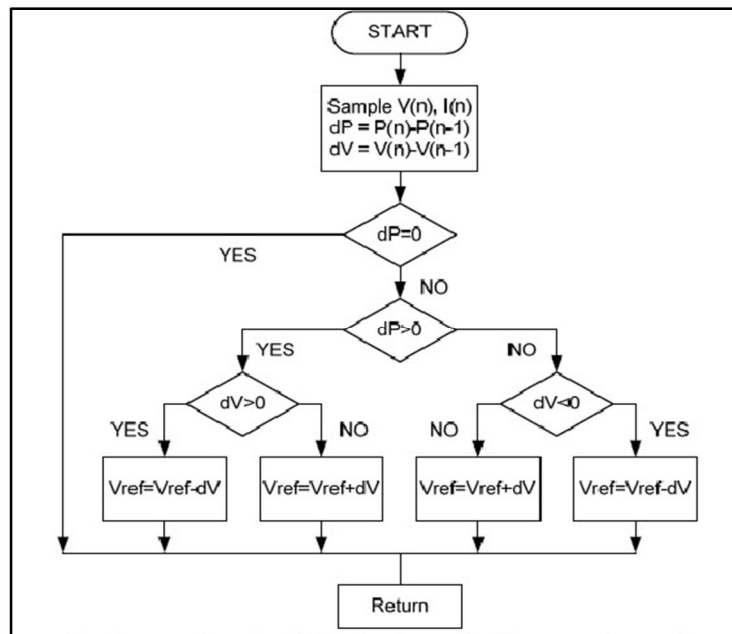

Fig 2 P&O Flow Chart

B. Incremental conductance method

The algorithm of INC MPPT depends on dP/dV , from the flow chart $V(k)$ and $I(k)$ are the present solar voltage and current with k is time variable. it reads the present solar panel voltage and current, and in the past, the solar panel voltage and current, which is equal to $V(k-1)$, and $I(k-1)$ is the voltage change dV in the current change dI . If the change in voltage $dV=0$ then it will check for current if change in current $dI=0$ then we get the output voltage. if the change in the output voltage $dV \neq 0$ then it will check for change in the conductance and solar panel conductance that is if $dI/dV = -I/V$ then we get the output voltage. if the $dI/dV \neq -I/V$ then it will check $dI/dV > -I/V$ that the changes in the conductivity is greater, then the solar panel conductance it means solar panel conductance is less, we have to increase the conductance of solar panel so we add an extra voltage ΔV so we get $V_{ref} + \Delta V$. If the change in the solar panel conductance is less than solar panel conductance $dI/dV < -I/V$ that is nothing but solar panel conductance is more than change in solar panel conductance then we have to decrement the conductance of solar panel $V_{ref} - \Delta V$. After checking the change in solar panel voltage $dV=0$ if the change in solar panel current $dI > 0$ if yes then the solar panel conductance will increase $V_{ref} + \Delta V$ if change in conductance is less that is $dI < 0$ then solar panel conductance will decrease $V_{ref} - \Delta V$ [11].

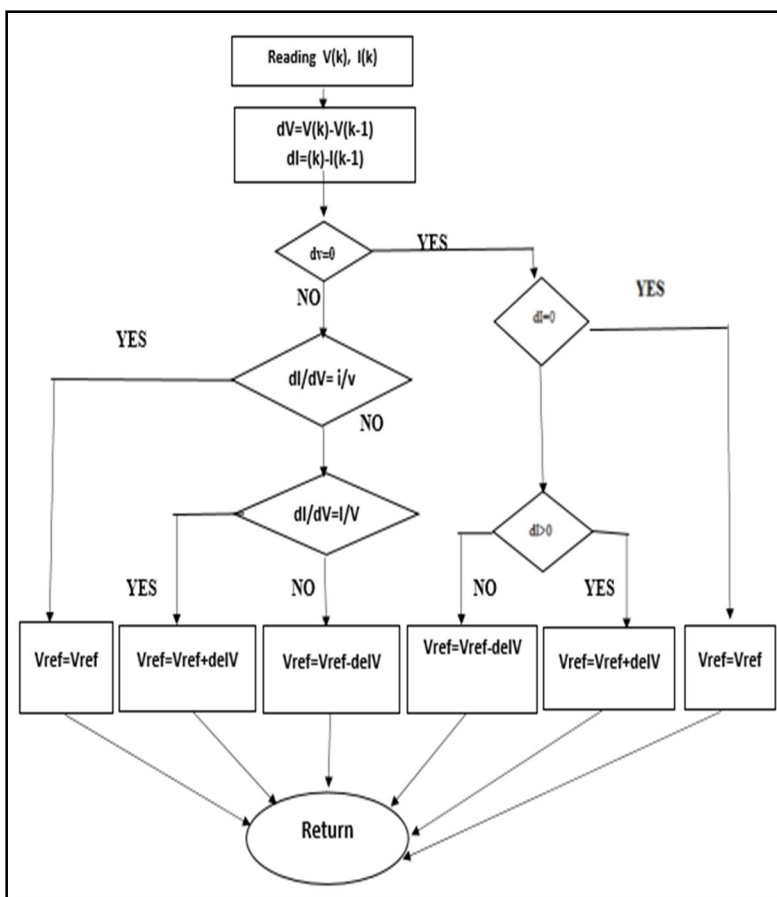

Fig 3 INC Flow chart

C. Fuzzy logic method

The fuzzy logic algorithm is used for fast response and it also improve the performance. the fuzzy logic requires the input voltage and current and the output will be duty cycle, this value of duty cycle is used for pulse-width modulation generation and this signal is used in the switch of the converter, the switch there are four different stages [10] The two observations are sensed from the input controller that is voltage and current (v_m) and (I_m) of a PV module. the output of the fuzzy logic duty cycle (D) will generate the pulse width modulation and this plus is given to the converter switch. The fuzzy logic subset, three subsets are small, medium and high are chosen for the input variables and trapezoidal shape is used for the membership function. the range for the member ship function taken from the PV model is ($V_{oc} = 37 V, I_{sc} = 8 A$).

IV. BOOST CONVERTER TOPOLOGY

The design of the DC / DC converter is important for PV application to get high output voltage from the low input voltage, but the solar system will operate at a low power supply voltage. high voltage is produced to get efficient conversion using DC-AC inverter. The output voltage of this DC-converter has to be within a range of about 800 volts DC for a typical DC link voltage for a three-phase.

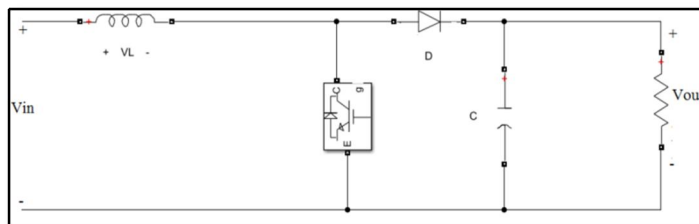

Fig 4 Boost converter

V. THREE LEVEL NEUTRAL POINT MULTILEVEL INVERTER

A multi-level NPC inverter consists of several levels, the capacitor voltage. A N-1 level inverter consists of (N-1) DC-bus capacitors, 2 (N) switching devices for each phase, and 2(N-2) clamping diodes for each phase. The power supply is divided into three levels of two DC capacitors, C1 and C2. This capacitor will divide the input voltage at the $V_{DC}/2$, the voltage is limited by means of a single capacitor, by the clamp diode [4].

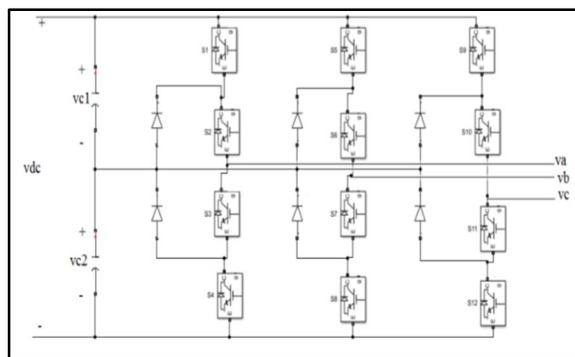

Fig 5 Neutral point clamped inverter

In the single leg operation, the switch S1 and S2 will operate the voltage across capacitor C1 will get as $+V_{dc}/2$ shown in fig 5. When switch S3 and S4 will operate then voltage across capacitor C2 will get as $-V_{dc}/2$ shown in fig 5 when both the switches S2 and S3 is operated then we get voltage as zero.

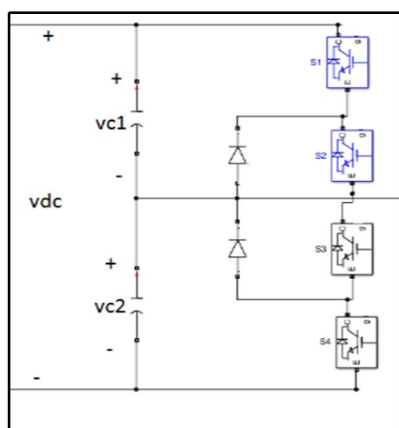

Fig 6 Mode one

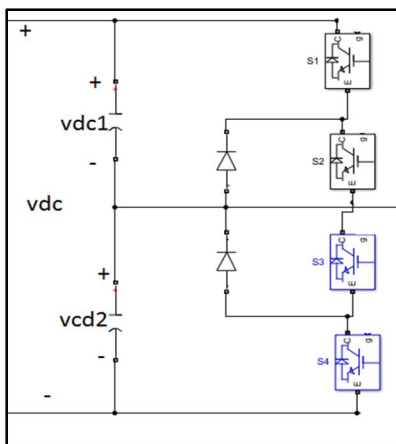

Fig 7 Mode two

Table 1 switching of the inverter

Voltage	Switching condition
+Vdc/2	S1 and S2 on, S3, and S4 off
0	S2 and S3 on, S1, and S4 off
-Vdc/2	S3 and S4 on, S1, and S2 off

VI. SINUSOIDAL PWM TECHNIQUE

Sinusoidal pulse width modulation as a PWM control method for setting the reference voltage to ac Vref is compared with the frequency of the carrier wave to determine the switching states of per leg inverter. during the comparison of each leg there are some rules which is shown below.

If reference voltage Vref > triangular wave Vc: higher switch will be turned on (leg voltage = vdc/2)

If reference voltage Vref < triangular wave Vc: higher switch will be turned on (leg voltage = -vdc/2)

The maximum value to triangular carrier wave is given to DC voltage Vdc. But the pwm technique the condition is that reference voltage Vref must be less than the carrier voltage Vc. that is Vref < Vc . for this PWM technique we used high frequency modulation voltage so it is called as carrier based PWM technique. also called as SPWM technique because the reference is given as sine wave. fig shown PWM technique for one phase [4].

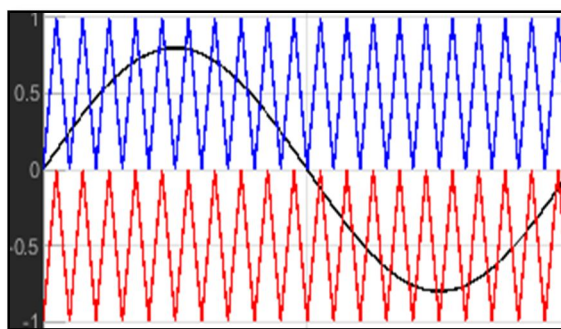

Fig 8 Pulse width modulation

VII. SYNCHRONOUS REFERENCE FRAME THEORY

The synchronous reference frame theory is used for reference current generation to develop in time domain reference current generation, the three phase Ia, Ib, Ic are converted into active and reactive components that is Id and Iq in rotating frame. it uses direct and inverse(dq) park transformation [8].it convert three phase reference frame a-b-c to d-q0, this two-phase id and iq will rotate at synchronous speed w in space, θ is transformation angle, and the current ia will rotate at angular speed w=2πf. This transformation is calculated by

$$\begin{bmatrix} I\alpha \\ I\beta \\ I0 \end{bmatrix} = \sqrt{\frac{2}{3}} \begin{bmatrix} 1 & -1/2 & -1/2 \\ 0 & \sqrt{3}/2 & -\sqrt{3}/2 \\ 1/\sqrt{2} & 1/\sqrt{2} & 1/\sqrt{2} \end{bmatrix} \begin{bmatrix} Ia \\ Ib \\ Ic \end{bmatrix}$$

$$\begin{bmatrix} Id \\ Iq \end{bmatrix} = \begin{bmatrix} \cos \theta & \sin \theta \\ -\sin \theta & \cos \theta \end{bmatrix} \begin{bmatrix} I\alpha \\ I\beta \end{bmatrix}$$

$$\begin{bmatrix} I\alpha \\ I\beta \end{bmatrix} = \begin{bmatrix} \cos \theta & -\sin \theta \\ \sin \theta & \cos \theta \end{bmatrix} \begin{bmatrix} Id \\ Iq \end{bmatrix}$$

$$\begin{bmatrix} Ia^* \\ Ib^* \\ Ic^* \end{bmatrix} = \sqrt{\frac{2}{3}} \begin{bmatrix} 1 & 0 \\ -1/2 & \sqrt{3}/2 \\ -1/2 & -\sqrt{3}/2 \end{bmatrix} \begin{bmatrix} I\alpha \\ I\beta \end{bmatrix}$$

A. Phase lock loop

For high accuracy and fast dynamic response, the PI controller with PLL algorithm is employed. The below figure shows three blocks that are low pass filter (PI controller) to attenuate the input AC components at high frequency. where the voltage-controlled oscillator will generate the sinusoidal voltage at the frequency of ω_q and low pass filter is used as PI control. the output power is transmitted to the input signal by $\pi / 2$ radians., by producing cosine function which makes the maximum frequency a double grid frequency that limits the bandwidth of PLL. So, the performance limits the bandwidth of PLL [6].

B. Synchronous Frame -PLL

For grid connected converters it is critical to control the phase angle of the grid, since there are control strategies like vector control, direct power control. to implement the control unit like dq reference frame and dq variables extraction. therefore, grid synchronization serves as the part of grid connected converters. there are many different approaches to achieve fast synchronization. but the grid voltage at the time of Grid synchronized might occur in usual or unusual conditions, like single phase grid voltage, three phase imbalanced grid voltage, or three phase distorted grid voltage [6]

VIII. SIMULATION MODEL

Fig 10 shows the system configuration. The boost converter was attached to the solar Power system, which increases the output voltage. of PV array. A Three-phase NPC (Neutral point clamped) inverter is connected by the boost DC-DC converter which is included in the system. This NPC inverter is connected to grid. This system includes an MPPT with voltage controller and the pulses are given to the boost converter.

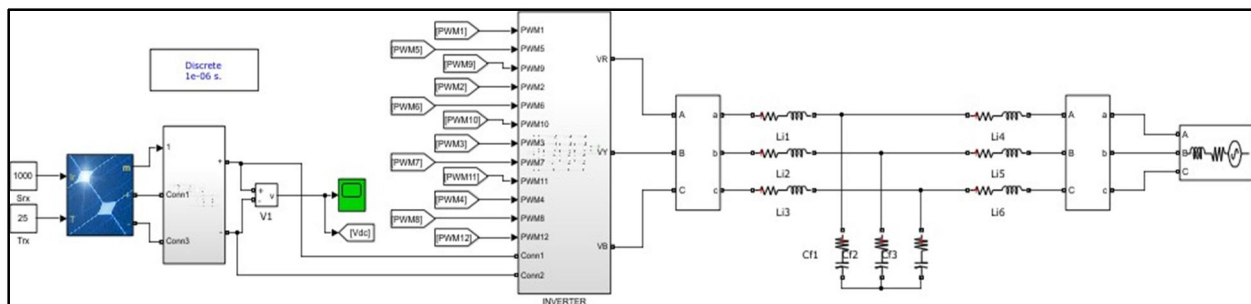

Fig 9 Simulink model of three phase grid connected three level NPC inverter.

A. Control strategy of perturb and observe method

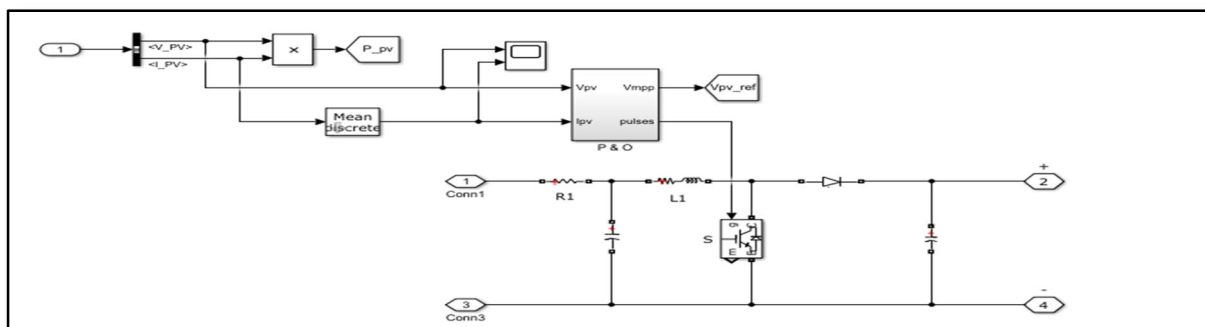

Fig 10 perturb and observe method

The p&o algorithm is developed by talking the solar panel voltage and solar panel current and given to the zero-order hold which will hold the values for 0.02 sec to calculate the change in voltage and power. the step of 5 volt is given to gel the change in output voltage.

B. Control Strategy of Incremental Conductance Method

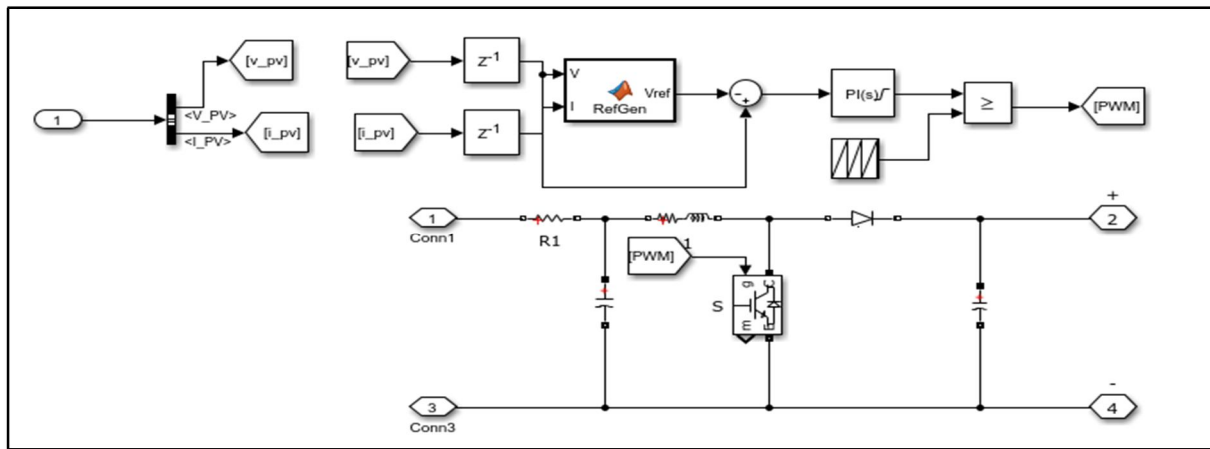

Fig 11 incremental conductance method

C. Control Strategy of fuzzy Logic Method

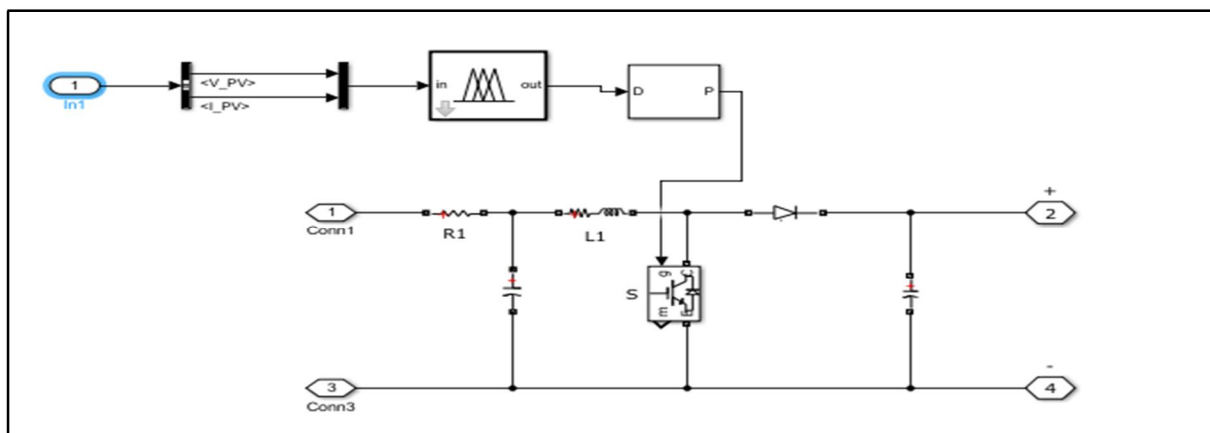

Fig 12 Fuzzy logic method

D. Perturb and Observation Results

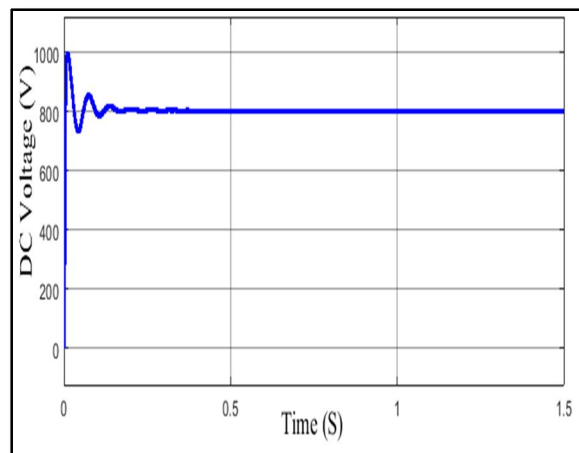

Fig (a) Irradiation at 1000 w/m2 and temperature 25C

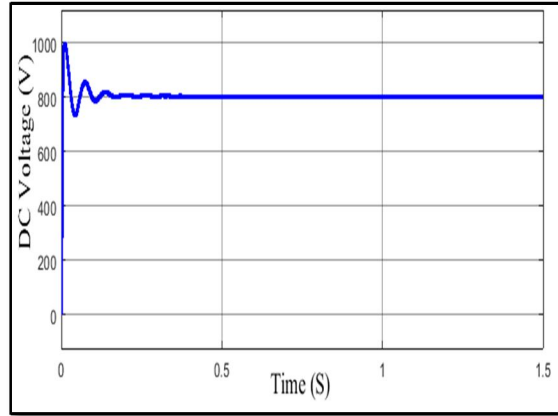

Fig (b) Irradiation at 600 w/m² and temperature 25C

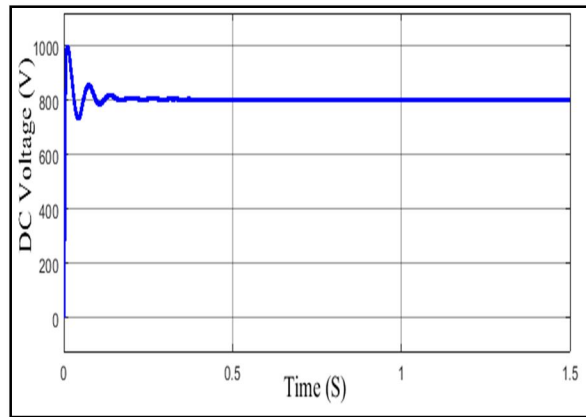

Fig (c) Irradiation at 400 w/m² and temperature 25C

- 1) The above results are performed firstly at standard constant temperature and irradiation conation at (G= 1000 w/m² an T = 25C)
 - 2) After the simulation is performed at variable irradiation (G) from 200 w/m² to 1000 w/m²
- From the fig a, b, c the above results are of perturb and observe method which we got constant output voltage at different irradiation and temperature.

E. Incremental Conductance Results

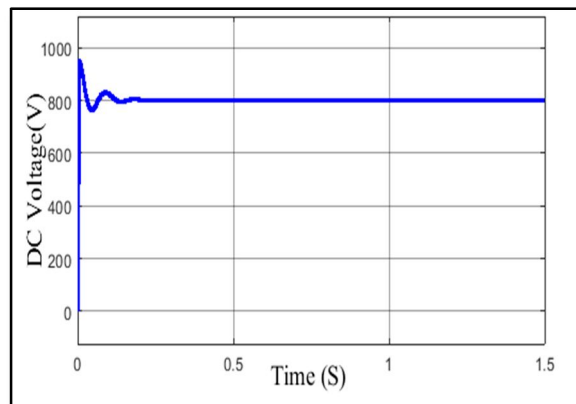

Fig (d) Irradiation at 1000 w/m² and temperature 25C

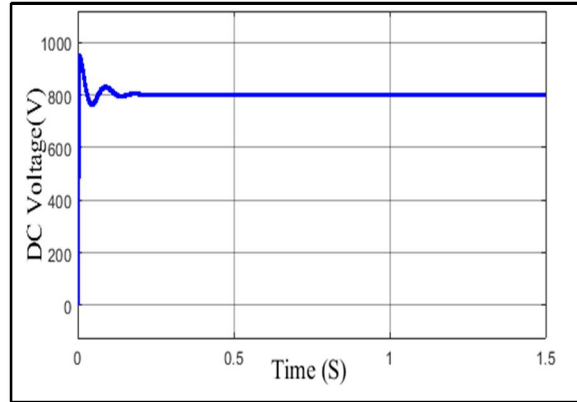

Fig (e) Irradiation at 600 w/m2 and temperature 25C

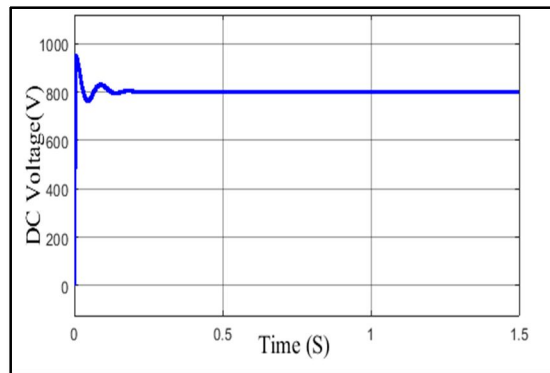

Fig (f) Irradiation at 400 w/m2 and temperature 25C

From the fig d, e, f the above results are of incremental conductance method which we got constant voltage at different irradiation and

temperature. compare to P&O, incremental conductance method offers better performance, with less oscillation.

F. Fuzzy logic results

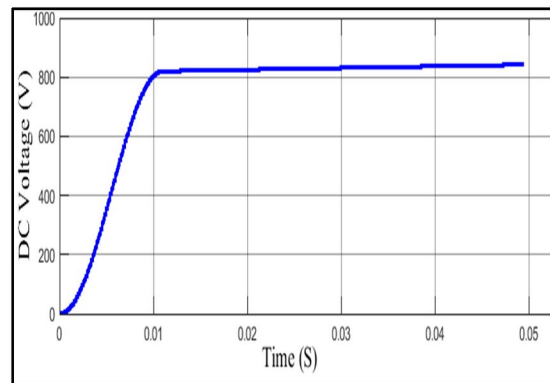

Fig (g) Irradiation at 1000 w/m2 and temperature 25C

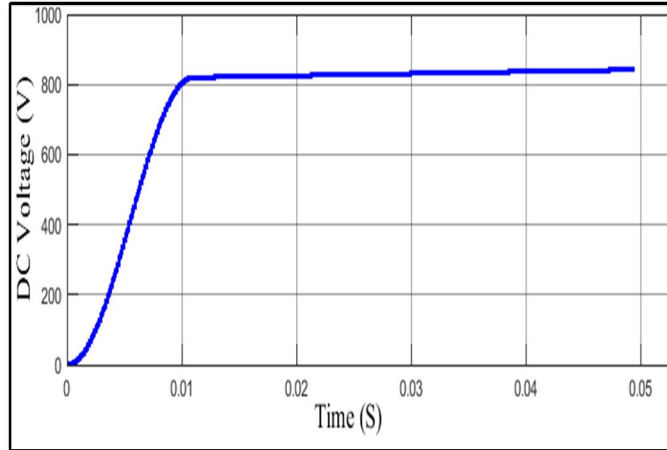

Fig (h) Irradiation at 600 w/m2 and temperature 25C

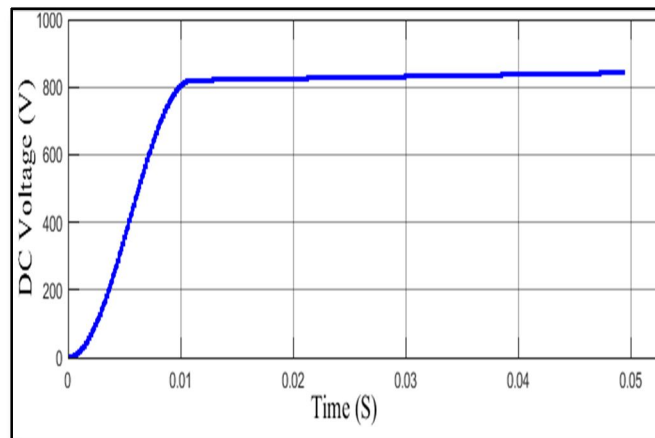

Fig (h) Irradiation at 600 w/m2 and temperature 25C

From the fig h, i, j the above results are of fuzzy logic method which we got constant voltage at different irradiation and temperature. compare to P&O and incremental conductance, fuzzy logic shows no oscillation and better stability.

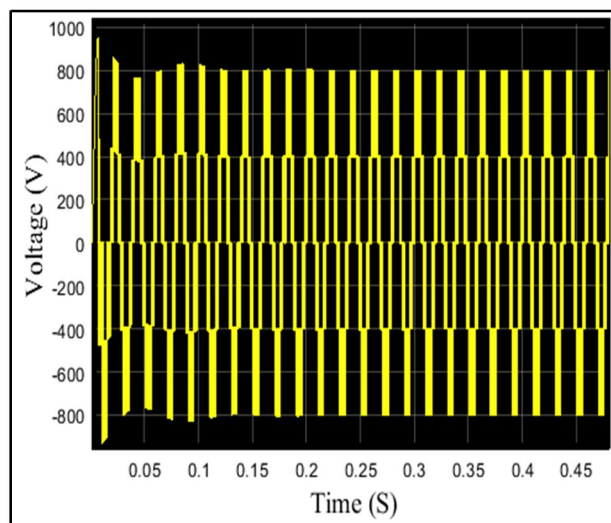

Fig 13 Three level NPC voltage

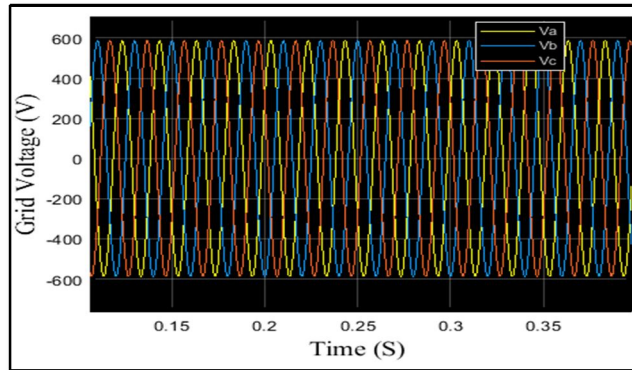

Fig 14 Grid Voltage waveform

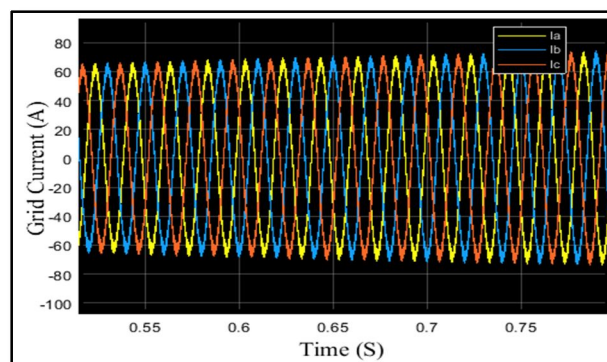

Fig 15 Grid Current Waveform

XI. CONCLUSION

It can be concluded by using a solar panel operating under constant irradiation and temperature we get oscillating voltage from P&O algorithm further the oscillations are reduced using incremental conductance algorithm and for fuzzy logic algorithm there is no oscillation and we get constant voltage during constant temperature and irradiation. Under varying irradiation and temperature from the solar panel using P&O, INC and Fuzzy logic algorithm we get constant voltage under varying climatic condition. The three level NPC inverter which is connected in between PV system and grid we get three level output voltage with grid synchronization waveform.

REFERENCES

- [1] J. Shreedevi , N. Ashwin , M. Naini Raju “ A Study On Grid Connected PV System “ IEEE 2016 National Power System Conference (NPSC).
- [2] Hangbin Wu, Xiaofeng Tao “Three Phase Photovoltaic Grid-Connected Generation Technology with MPPT Function and Voltage Control” IEEE 2019 International Conference on Power electronic and Drives system (PEPS).
- [3] GUO Xiao Yun , CHEN JinMei , LIU QiHui “Real-time and grid-connected control of PV Power System ” IEEE 2011 International Conference on Advanced Power System Automation and protection.
- [4] K. Boudaraia, H. Mahmoudi and M. El Azaoui, "Modeling and control of three Phases grid connected photovoltaic system," 2016 International Renewable and Sustainable Energy Conference (IRSEC), 2016, pp. 812-816, doi: 10.1109/IRSEC.2016.7984004.
- [5] Liqun Shang, Weiwei Zhu, ZhuJun Li “A Control Method of PV Grid Connected Inverter Under Grid Voltage Unbalanced Drops” IEEE 2018 Chines Control and Decision Conference.
- [6] S.K Chung “Phase-Locked Loop For grid-connected three-phase power conversion systems” IEE Proceedings electric power applications.
- [7] H. Altas and A. M. Sharaf, "A Photovoltaic Array Simulation Model for Matlab-Simulink GUI Environment," 2007, pp. 341-345, doi: 10.1109/ICCEP.2007.384234.
- [8] F. Shaikh and B. Joseph, "Simulation of synchronous reference frame PLL for grid synchronization using Simulink," 2017 ICAC, pp. 1-6, doi: 10.1109/ICAC3.2017.8318790.10.
- [9] Y. Thiagarajan, T. S. Sivakumaran and P. Sanjeevikumar, "Design and simulation of fuzzy controller for a grid connected stand alone PV system," 2008 IEEE, 2008, pp. 1-6, doi: 10.1109/ICCCNET.2008.4787740.
- [10] M. Naiem-Ur-Rahman, S. Newaz and M. M. Rana, "A Fuzzy Based MPPT Controller for PV System," 2020 IEEE (GUCON), 2020, pp. 635-638, doi: 10.1109/GUCON48875.2020.9231093.
- [11] Radianto, G. M. Dousouky and M. Shoyama, "MPPT based on incremental conductance-fuzzy logic algorithm for photovoltaic system under variable climate conditions," 2015 IEEE INTELEC, 2015, pp. 1-5, doi: 10.1109/INTLEC.2015.7572489.



10.22214/IJRASET



45.98



IMPACT FACTOR:
7.129



IMPACT FACTOR:
7.429



INTERNATIONAL JOURNAL FOR RESEARCH

IN APPLIED SCIENCE & ENGINEERING TECHNOLOGY

Call : 08813907089  (24*7 Support on Whatsapp)