



IJRASET

International Journal For Research in
Applied Science and Engineering Technology



INTERNATIONAL JOURNAL FOR RESEARCH

IN APPLIED SCIENCE & ENGINEERING TECHNOLOGY

Volume: 9 Issue: VIII Month of publication: August 2021

DOI: <https://doi.org/10.22214/ijraset.2021.37247>

www.ijraset.com

Call:  08813907089

E-mail ID: ijraset@gmail.com

Front Desk Humanoid Officer Using CNN Algorithm

Mala Sinnor¹, Kiran Gowda N², M. Varshini Urs³, Lavanya RT⁴

^{1, 2, 3, 4}Department of Electronics and Communication Engineering, Dr. Ambedkar Institute of Technology, Bangalore 560079, India

Abstract: This paper presents an example of using front desk humanoid officer that is a receptionist at college. A Raspberry pi-based face recognition, face mask detection is provided. When this robot used in check in process reduces cost and can be used as a great alternative for human receptionist in this growing pandemic era. This system provides security by avoiding possible unauthorized people entering into college premises and also assist visitors with route map to department.

Keywords: Raspberry Pi, face recognition, mask detection, RFID scan, LCD display

I. INTRODUCTION

In today's day to day life artificial intelligence will play a serious role. Artificial intelligence makes factors straightforward. Robotics makes thing simple. The main focus of any robotic system is reducing the human labour, efforts, time and errors that is caused due to human negligence [1]. In the near future, robots will perform several types of services and also assistive tasks, and be extensively used as helpers in activities of daily living. So as to realize the acceptance of robots, their style ought to be planned fastidiously in line with their role. Secretarial assistant could be a job that's helpful as support for folk in lifestyle, which will doubtless be performed by colloquial agents likewise as robots. Computers are getting to be indispensable nowadays. Many of us, however, do not think they are friendly. Intelligent robots can build an opportunity for us to use a laptop in existence. Though a variety of robots with human options square measure already accessible. It's required to regulate their behaviour supported specific task to hold out. We are going to be introducing a robot for the faculty counter.

In this paper, a robot we'll be working on its face recognition capabilities and voice recognition as, the voice is a key element especially in face-to-face communication not only because it conveys the information, however conjointly as a result of it contains extremely relevant cues for social interactions [2][4]. Therefore, sensitivity to voice and language cues has always played a vital role along evolutionary history in human social groups. The pitch, alongside the timbre, volume and speech rate is one among the foremost important voice characteristics.

The rest of this paper is in the order as follows, Section II explains the Objectives and Section III deals with the system description. Results and main conclusions are shown in Section IV and Section V.

II. OBJECTIVES

The main objective of the project is to build a robot that provides helpful services as receptionist in college. The designed robot will detect whether the person is wearing the mask while time of entering and it will inform the person to wear back his or her mask after authentication [6]. The robot in this project is designed to provide a security system by authentication of person entering using face detection. Front desk humanoid robot is capable of performing some of the tasks that a receptionist would do, for example looking up office numbers and providing the direction by voice command as well as by sending a route map to the person's mail id in the form of text [8].

III. BLOCK DIAGRAM

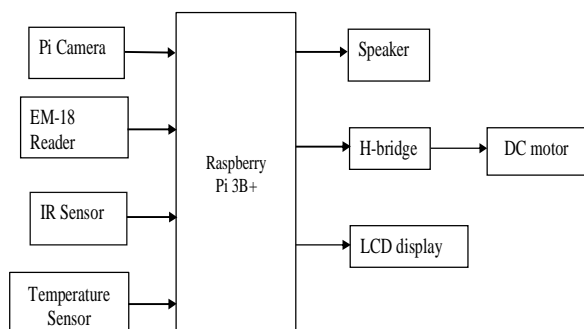

Fig. 1 Block diagram of Receptionist robot

We have proposed a Humanoid Front Desk Officer which can do the job of the receptionist at the college. With respect to the above figure 1 we have Raspberry pi 3B+, H-Bridge, DC motor which helps in the movement, The Infrared Sensor is used for detecting the person or object in front of the model and the Pi cam interfaced to Raspberry pi module is used take live video stream and also to detect if the person is wearing a mask or not. Temperature Sensor is used for measure the temperature of the visitor, EM-18 Reader Module scans the RFID card, the Speaker is to give voice output and date and time will be displayed using LCD display [5].

IV. SYSTEM REQUIREMENTS

A. Hardware Requirements

1) Raspberry Pi 3 B+:

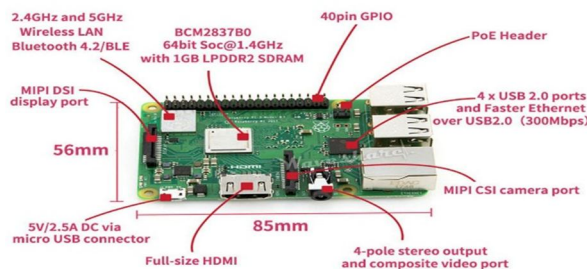

Fig. 2 Raspberry pi 3 B+

- a) SOC: Broadcom BCM2837B0, Cortex-A53 (ARMv8) 64-bit SOC
- b) CPU: 1.4GHz 64-bit quad-core ARM Cortex-A53 CPU
- c) RAM: 1GB LPDDR2 SDRAM
- d) WIFI: Dual-band 802.11ac wireless LAN (2.4GHz and five GHz) and Bluetooth 4.2
- e) Ethernet: Gigabit Ethernet over USB 2.0 (max three hundred Mbps). Power-over-Ethernet support (with separate power-over-Ethernet HAT).
- f) It has thermal management.
- g) For Video it uses Video Core IV 3D. Full-size HDMI
- h) It has audio
- i) USB 2.0: 4 ports
- j) GPIO: 40-pin
- k) Power: 5V/2.5A DC power input
- l) It supports operating system like Linux and Unix.

2) H-bridge:

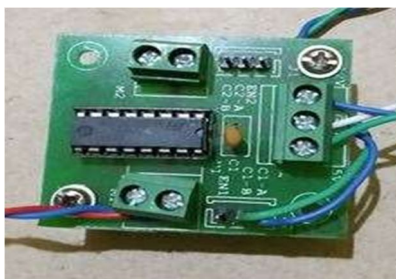

Fig. 3 H-bridge

It's a motor driver. H-Bridge will control the direction of motor such as forward or backward. The operating voltage is 5v.

3) *Dc Motor*



Fig. 4 Dc motor

RPM (revolutions per minute) is the foremost necessary specifications of a DC motor. It is number of times the shaft of a DC motor completes a full spin cycle per minute. The operating voltage of a DC motor is 5V.

4) *EM-18 Reader Module*



Fig. 5 EM-18 Reader Module

Radio frequency identification (RFID) technology is a wireless communication technology that enables users to uniquely identify tagged objects or people.

5) *Speaker*



Fig. 6 Speaker

A speaker is an associate device that converts analog audio signals into the equivalent air vibrations so as to form audible sound with 3.5mm jack for compatibility.

6) *Pi Cam*

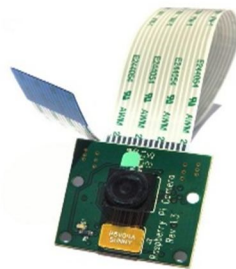

Fig. 7 Pi cam Rev 1.3

The 5MP or 1080p HD video at 30fps resolution Raspberry Pi Camera Model B Rev 1.3. Rev 1.3 is the latest version. To the Camera Serial Interface of the Raspberry pi 3B+ using 15pin Robbin cable this camera is attached.

7) *LCD Display*



Fig. 8 LCD display

Liquid Crystal Display can display in 4 rows with 20 characters each it also supports parallel interface of 4 or 8 bits, its operating voltage is 4.7V to 5.3V and 1mA of power consumption.

8) *Infrared Sensor*



Fig. 9 Infrared Sensor

The IR Sensor Module has an infrared transmitting diode and receiving diodes, the Infrared light rays gets reflected back whenever the transmitted infrared light waves incident on any object and this reflected Infrared waves are going to be received by the receiver diode. It has a 3 pin interface with VCC, GND, and an Output pin the operating voltage range is 3.3 to 5V. The effective distance range of this sensor is 2cm to 5cm.

9) *Temperature Sensor LM35 DZ:*

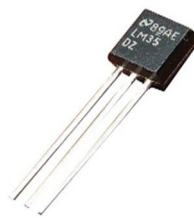

Fig. 10 Temperature Sensor LM35 DZ

The Temperature Sensors are a simple instrument that is used to measure the temperature in degrees of an object or a person by coming into contact with the object or person or it remotely detects the infrared energy emitted by the object or person in readable form through an electrical signal and operating voltage is 1.5V to 5.5V range.

V. METHODOLOGY

- 1) *Welcome Gesture:* If a Person is Detected then the officer will greet the visitor by the gesture and Welcome note this is achieved using Haar-cascade Face recognition Algorithm.
- 2) *Temperature Check:* Visitor's temperature is recorded and if the temperature is below a threshold value, then the officer will respond as Normal Temperature else cannot let you in.
- 3) *ID card Check:* The officer will ask the visitor to scan their ID card if the scanned ID card is valid then the officer will ask for further Queries from the visitor. If the scanned ID card is invalid the visitor is asked to provide a proper ID card.

- 4) If the query is related to principle's appointment, then captured image and provided ID card of the person is sent to the principle's PA asking for the appointment. The PA respond to the appointment based on principle's availability and the officer's action would be in accordance to the response from the PA. If the permission is given, then the officer will allow or ask the visitor to wait [7].
- 5) *Route Map*: The officer guides the visitors about the place they want to go in and around the campus by sending the route map to the person's mail id.
- 6) *Mask Detection*: The officer checks whether the person is wearing the mask if the mask is on the person's face it will ask to remove it to proceed with the authentication process after this process completes it will ask the person to wear back the mask. This can be achieved using Convolution Neural Network Algorithm [3].
- 7) *Display*: The officer displays the current date and time.

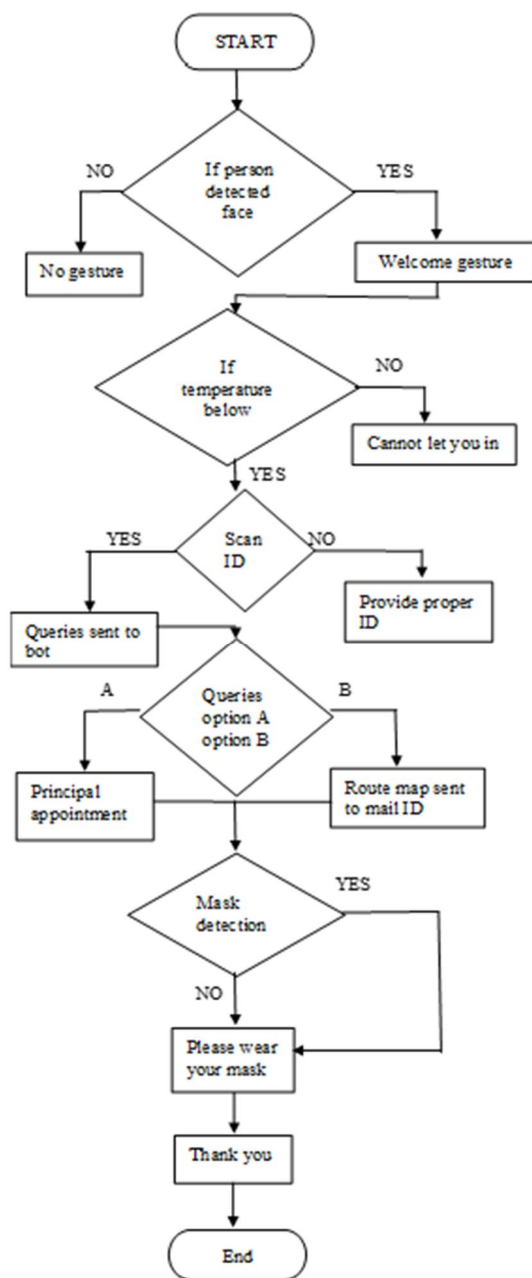

Fig. 11 Flow-chart of Front Desk Humanoid officer

VI. ADVANTAGES

- A. The foremost characteristic of a robot is that they can literally work for what they are programmed to do 24 x 7 with error free but humans get tired by working all day.
- B. The primary advantage of using this kind of robots in colleges is their cost is now decreasing and are much cheaper than humans.
- C. In reality a human skills or ability cannot be compared with robot's fast growing capability for example whenever a person visits an office for second time a human receptionist will not be able to recall the person name but a receptionist robot can immediately recognize person and display the details.
- D. Whenever a important person or an official visit the college the human hands might tremble or shake, but since the robotic arms are smaller and adaptable moving parts that aid them in acting their chore with additional precision than humans and are significantly stronger.
- E. Robots are available any form and dimensions, relying over the requirement of the chores.
- F. Currently the pandemic situation is still not in control, having humans work in the front desk will be arduous but the Robots can work in any environmental condition.

VII. DISADVANTAGES

- A. As the efficiency of the robots are increasing in numerous businesses, due to which the humans are no longer needful in production plants thus unemployment rate increases in the country.
- B. The Robots are not capable of handling unexpected situations.
- C. There should be collaboration of Human and Robot since the return on outlay of business may perhaps have downfall if the functioning solely counts on numerous robots, since the robots' expenses are greater than humans.
- D. The robots are pre-programmed and they work on only specific task based on the information given to them, if one thing goes wrong, the College administration has to bear the loss.

VIII. RESULT

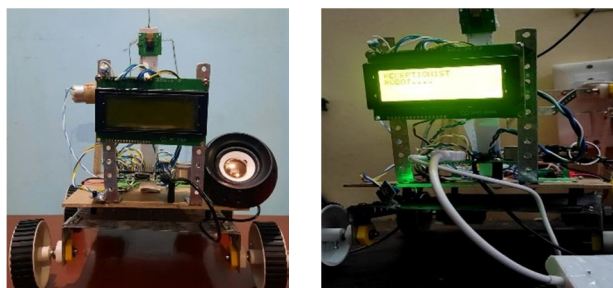

Fig 12: Humanoid front desk officer

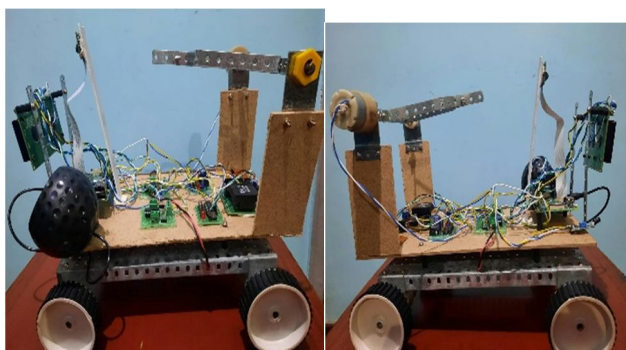

Fig 13: Side views of humanoid front desk officer

- 1) When college students, faculty and the employees of the college stand in front of the model they will be detected as known person.

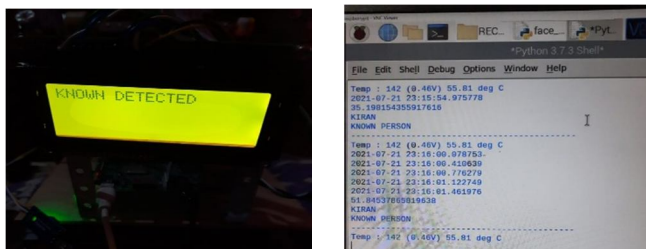

Fig 14: Display of known person

Then temperature check is done and date and time will be displayed as shown below.

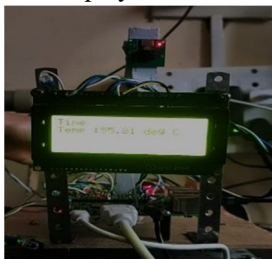

Fig 15 : Display of date and time

- 2) If an unknown person stands in front of the model it will ask for ID card scan.

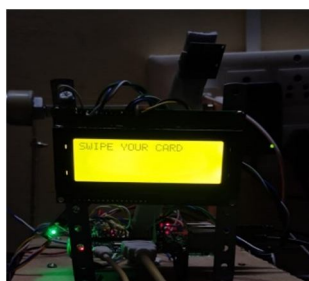

Fig 16: Asking for card scan

- 3) If the Id card scanned is authorized then robot will ask for the person queries.
- 4) If the person query is about Principal Appointment then request is sent to Principal PA.

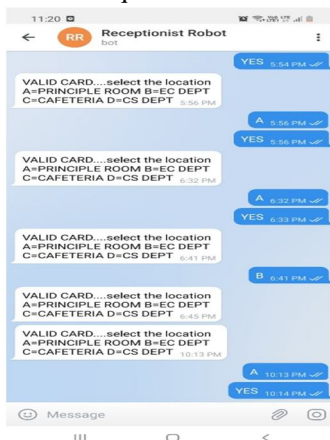

Fig 17: Interaction through bot

5) After the approval of Principal appointment from PA the robot sends the route map to visitor's mail ID.

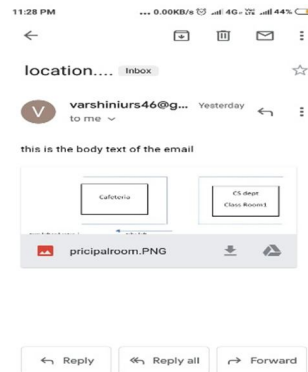

Fig 18: route map sent to mail ID

6) If the person wants to go to EC department the route map is sent to his mail ID.

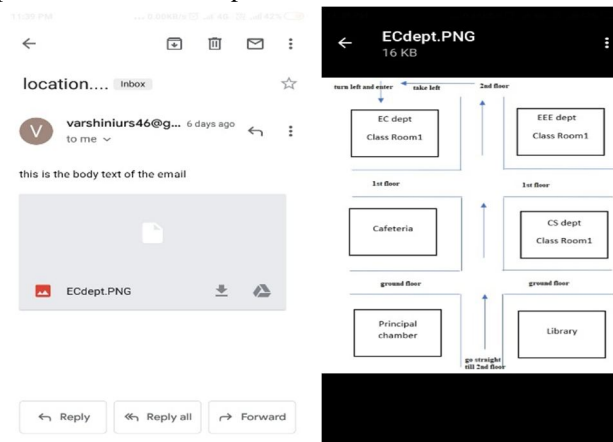

Fig 19: route map of EC dept sent to visitor's mail ID

7) After the completion of visitor's queries, the robot reminds the visitor to wear the mask with the voice note.

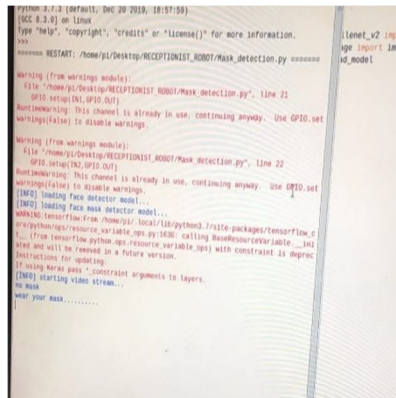

Fig 20: Asking the person to wear back his mask

IX. CONCLUSION

The proposed system would be best model as the robotics technology is blooming with this emerging pandemic situation. So, we have created a novel front desk officer which can contribute to public health care department. The face mask detection is done using CNN model and also we have used Open CV, Tensor Flow and python to detect whether the visitor is wearing a mask and face recognition through Haar-cascade Algorithm. This system provides a promising accuracy and the optimization of the model is continuous process. Using this model any unauthorized entry can be reduced to maximum extent possible.

X. FUTURE WORK

The future work on the proposed prototype system will be creating a database system and server in which the visitor's information is stored and can be retrieved whenever needed. Any Real Time Authorized ID card can be scanned using real time ID card scanner with these changes the proposed system can be used in Hospitals, Work places, Hotels, Banks and other sophisticated places.

XI. ACKNOWLEDGEMENT

The contentment in the accomplishment of this piece of work would be incomplete without the people who made it possible, and without our lectures constant guidance and encouragement would have made all our efforts go in vain. We manifest our regard towards all those who guided in completion of the project.

REFERENCES

- [1] Hanaa Mohsin Ahmed; Rana Talib Rasheed "A Raspberry PI Real-Time Identification System on Face Recognition", Year: 2020 | Conference Paper | Publisher: IEEE
- [2] Sunitha M. R, Fathima Khan, Gowtham Ghatge R, Hemaya S "Object Detection and Human Identification using Raspberry Pi", Year: 2019 | Conference Paper | Publisher: IEEE.
- [3] Meghana Shinde¹, Tanvi Sukhadare², Soham Vaidya³, Prof. Meghali Kalyankar⁴, "Face Mask Detection Alert System using Raspberry Pi", International Research Journal of Engineering and Technology (IRJET), Volume: 08 Issue: 04 | Apr 2021.
- [4] Hasan Hashib;Md. Leon;Ahmed Mortuza Salaque " Object Detection Based Security System Using Machine Learning Algorithm and Raspberry Pi",Year:2019 | Conference Paper | Publisher : IEEE
- [5] Ramiro Sandoval; Vanessa Camino; Ricardo Flores Moyano ; Daniel Riofrío; Noel Pérez; Diego Benítez "On the Use of a Low-Cost Embedded System for Face Detection and Recognition", Year: 2020 | Conference Paper | Publisher: IEEE.
- [6] T. T. Chee, A. H. Y. Wong, D. K. Limbu, A. H. J. Tay, Y. K. Tan, and T. Park, "Understanding Communication Patterns for Designing Robot Receptionist", in Social Robotics, S. S. Ge, H. Li, J.-J. Cabibihan, and Y. K. Tan, Eds. Springer Berlin Heidelberg, 2010, pp. 345–354.
- [7] T. Komatsu, "Comparison an Onscreen Agent with a Robotic Agent in an Everyday Interaction Style: How to Make Users React Toward an On-screen Agent as if They Are Reacting Toward a Robotic Agent", in Human-Robot Interaction, D. Chugo, Ed. InTech, 2010.
- [8] T. Komatsu, Y. Seki, R. Sasama, T. Yamaguchi, and K. Yamada, "Investigation of Users' Reactions Toward Various Kinds of Artificial Agents: Comparison of a Robotic Agent with an On-screen Agent", presented at the Universal Access in Human-Computer Interaction. Year 2011.



10.22214/IJRASET



45.98



IMPACT FACTOR:
7.129



IMPACT FACTOR:
7.429



INTERNATIONAL JOURNAL FOR RESEARCH

IN APPLIED SCIENCE & ENGINEERING TECHNOLOGY

Call : 08813907089  (24*7 Support on Whatsapp)