



# IJRASET

International Journal For Research in  
Applied Science and Engineering Technology



---

# INTERNATIONAL JOURNAL FOR RESEARCH

IN APPLIED SCIENCE & ENGINEERING TECHNOLOGY

---

**Volume: 9      Issue: VIII      Month of publication: August 2021**

**DOI: <https://doi.org/10.22214/ijraset.2021.37556>**

**[www.ijraset.com](http://www.ijraset.com)**

**Call:  08813907089**

**E-mail ID: [ijraset@gmail.com](mailto:ijraset@gmail.com)**

# Performance Evaluation of Single-Phase On-Board Charger with Advanced Controller

Mr. Akshay A. Khandare<sup>1</sup>, Mrs. Manjiri M. Tamhankar<sup>2</sup>

<sup>1</sup>PG Student, Department of Electrical Engineering (MTechControlSystem)

<sup>1</sup>Assistance Professor, Department of Electrical Engineering, Walchand College of Engineering, Sangli-416415, India

<sup>2</sup>PGStudent, Department of Electrical Engineering (MTech Control System)

**Abstract:** The increasing mobility of electric vehicles has inspired vehicle growth to power grid technology. Such as vehicle to grid technology allows to transfer the power from the electric vehicle battery to the power grid. This enable speak load shaving, load leveling, voltage regulation, and improved stability of the power system. To develop the vehicle to grid technology requires a specialized EV battery charger, which permits the bi-directional energy transfer between the power grid and the electric vehicle battery. There is a specific control strategy used for a bi-directional battery charger. The proposed control strategy is used for charge and discharge battery of EV. The charger strategy has two parts: 1) Bidirectional AC-DC Converter in two-way Communication System. 2) Bidirectional DC-DC Buck-Boost Converter. There are two modes of operation for a bidirectional ac-dc converter: for G2V, rectifying mode is used, and for V2G, inverter mode is used. The suggested charge strategy not only allows for two-directional power flow but also provides power quality management of the power grid. Fuzzy logic controller (FLC) transforms linguistic control topology evaluations knowledge into an automated control topology using FLC. The FLC is more stable, has less overshoot, and responds quickly. The operation of a standard PI controller and a FLC was compared in this study using MATLAB and Simulink, and different time domain characteristics were compared as to show that the FLC had a smaller overshoot and a faster response than the PI controller.

**Keywords:** Bi-directional AC-DC converter, bi-directional DC-DC Buck-Boost converter, electric vehicles (EVs), on-board battery charger (OBC), grid to vehicle (G2V), vehicle to grid (V2G).

## I. INTRODUCTION

The carbon-dioxide emissions have risen, as have commercial fuel prices, causing substantial worry in today's transportation sector. Despite having matured and refined internal combustion engine technology, the transportation sector accounts for almost half of worldwide greenhouse gas emissions. As a result, there is a lot of pressure to switch to a long-term solution, such as an electric vehicle. Due to their clean, efficient, and environmentally friendly nature, EVs have recently gained a lot of attention. Bi-directional power transfer and power control modes are the two important modes of operation. The battery of an electric vehicle is charged in the G2V mode, and the energy is produced by the utility grid[1]. In this paper, we have used the two controllers for comparison purpose. The first controller is PI controller and second is fuzzy controller; the PI controller is used for proper tuning the results and fuzzy logic controller is used for approximate reasoning is possible. Fuzzy logic systems respond faster and more smoothly than older method and their control complexity is smaller.[8]

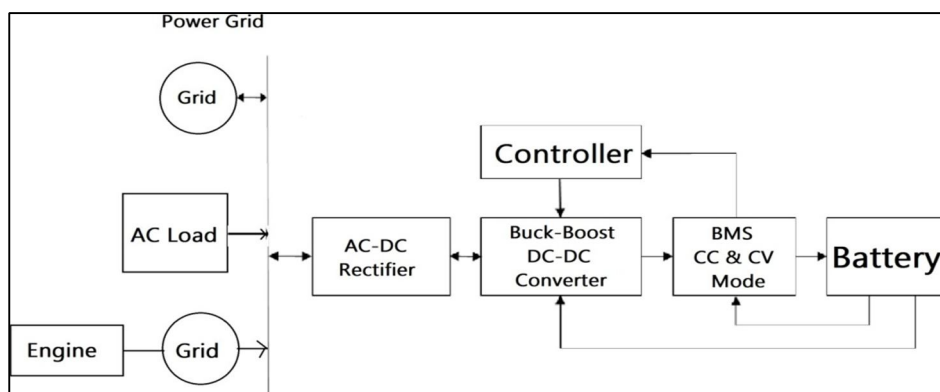

Fig.1 block diagram for Bi-directional Battery Charger

The fig. 1 represent the block diagram of bi-directional battery charger, it has showing the G2V and V2G topology. This topology to benefits the energy management of the utility grid. Additionally, the bidirectional onboard charger may regulate power quality functions such as voltage control and power factor adjustment. The control technique for Bidirectional Charger Modeling the direction of current flow can be used to indicate the direction of power flow.[2] In that work, the bidirectional power flow is controlled using the direct current control methodology for bidirectional power transfer implementation.

## II. OVERVIEW OF BI-DIRECTIONAL CHARGER

The bidirectional battery charger is implemented for an electric vehicle because power can be transferred from bidirectional power transfer. There are various topologies available for bidirectional battery charger. In this system, single-phase Cascade ac to dc converter and dc to dc(buck-boost) converter is used. In this dissertation non-isolated converter and its control are discussed. The interleaved converter has advantages such as minimizing current ripple and converter size.

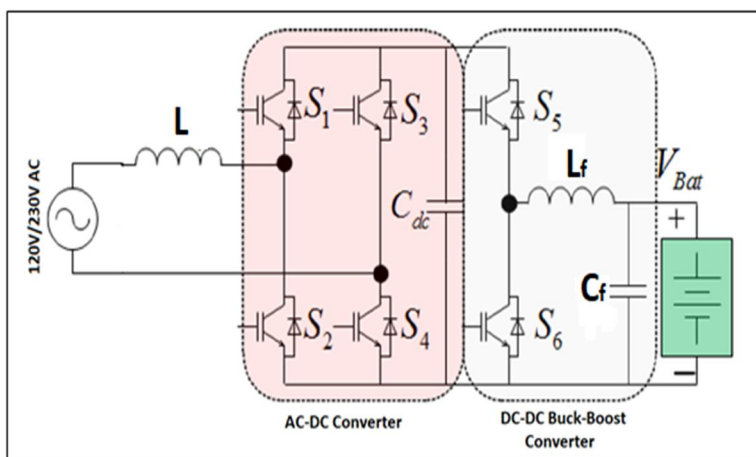

Fig.2 Topology of a single-phase bi-directional charger system

Fig. 2 The topology circuit shows the bi-directional G2V and V2G mode. The system includes the two converter single-phase ac to dc converter and single-phase dc-dc buck-boost converter. The above circuit connects a single-phase ac-supply to a bi-directional ac-dc converter, which boosts the dc output and regulates the DC-Link voltage.

## III. SINGLE-PHASE ON-BOARD BI-DIRECTIONAL CHARGER

Table I

PARAMETERS OF TOPOLOGY USE IN THIS PAPER		
Parameters	Symbol	Value
Grid voltage	$V_s$	230Vrms, 50Hz
Grid inductance	$L$	10mH
DC-link voltage	$V_{dc}$	380V
DC-link capacitance	$C_{dc}$	20kuF
Filter inductor	$L_f$	10mH
Filter capacitor	$C_f$	10kuF
Battery voltage	$V_b$	120V, 10Ah

From the above table I, shows the proposed single-phase Bi-directional charger system need 230Vrms, 50Hz grid supply; 120V, 10Ah for the battery voltage.

#### IV. PWM CONVERTER FOR AC-DC CONVERTER

The control strategy for the PWM converter is shown in fig. 3.1 the switching signals are generated by the close loop control system. In Voltage controller, the PI controller has been used this PI controller receives the error signal between the reference and output voltages and reduces it to zero.

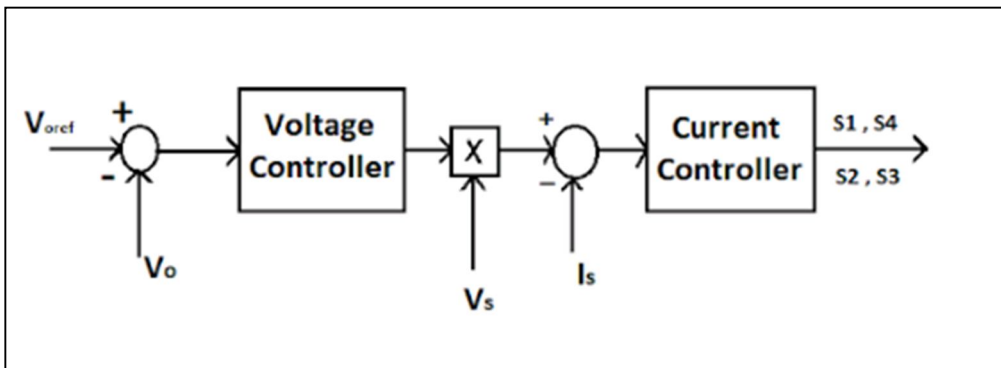

Fig. 3.1 Classical control scheme for PWM converter of AC-DC converter

The output of voltage controller goes to the multiplier with the supply voltage and forms a reference current. In Current Controller, the Hysteresis controller is used. The hysteresis controller receives the reference current and feedback current, it is used to generate the switching signals for S1,S4 and S2,S3 switches.[3]

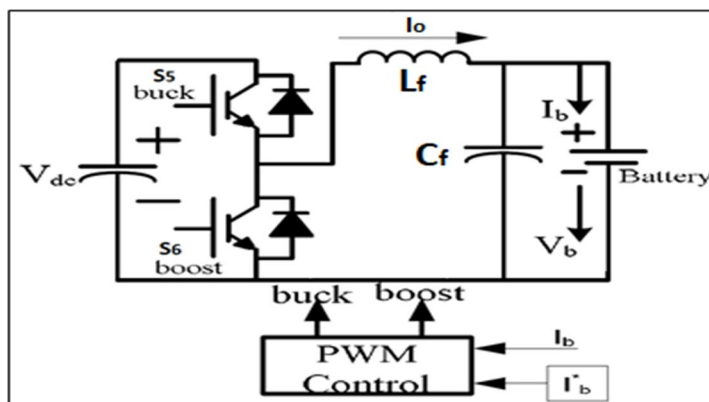

Fig.3.2 Bidirectional DC-DC buck-boost Converter

As shown in Figure 3.2 the two quadrants DC-DC converter consists a inductor, a capacitor and two IGBT switches with fixed diodes. The DC-DC buck-boost converter is shown in Fig.3.2 when the DC-link voltage is higher than battery voltage of an electric vehicle in charging mode, so it works as a buck converter. When battery is in discharge mode, it acts in boost mode.

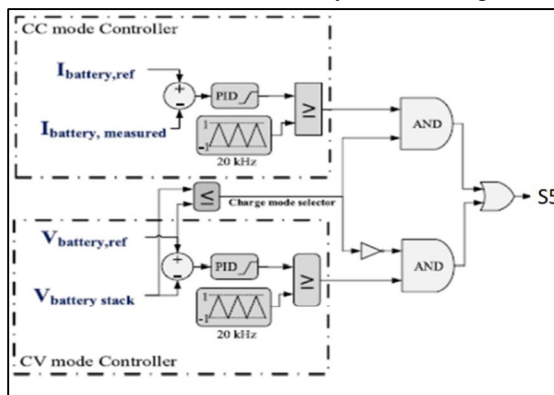

Fig.3.2 Control algorithm for DC-DC buck converter



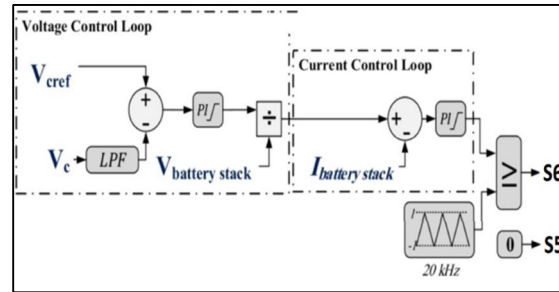

Fig.3.3 Control algorithm for DC-DC boost converter

In G2V mode the charger performs in battery charging mode, then the converter acts as a buck converter shown in figure 3.2. To generate this mode,  $S_6$  is switched off and  $S_5$  is switched on and off with the CC CV control strategy. The reduction ratio of the voltage varies according to duty cycle of signal which is given to  $S_5$ .

Fig.3.3 shows DC-DC converter, When the circuit is in battery discharge mode, in V2GDC- DC converter acts as a boost converter in that  $S_5$  continuously off while  $S_6$  is switched on and off with the CC CV technique. The battery voltage is increased by a factor of  $1/(1-D)$ , where  $D$  is the duty cycle of the signal which is given to  $S_6$ . Battery discharge current and dc-link capacitor voltage are regulated with PWM switching of the  $S_6$ . [6]

### V. SIMULATION RESULTS

The simulation configuration is represented in Fig. 4 to evaluate the proposed bidirectional converters and its control approach.

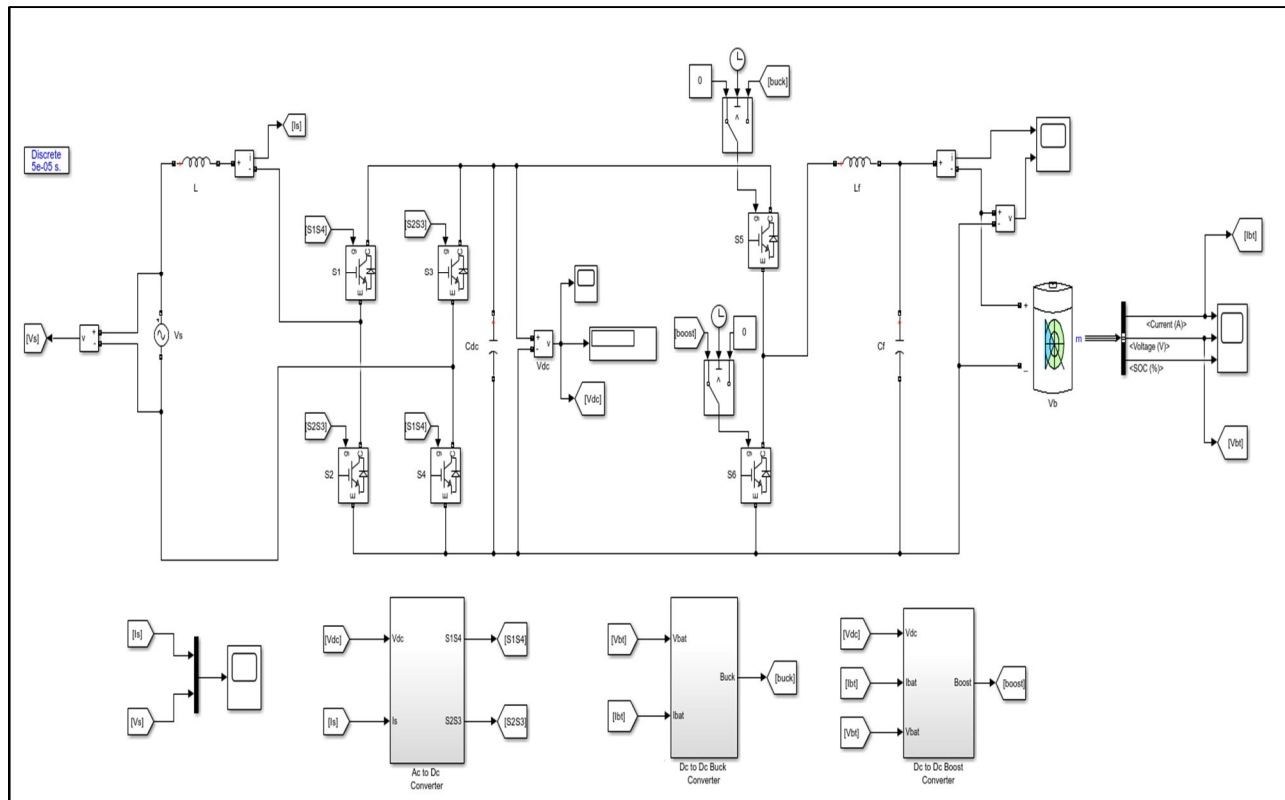

Fig.4 MATLAB simulation model for bidirectional converters for battery charging.

Fig. 4 represents the MATLAB simulation diagram for the proposed model of bidirectional battery charger. The designs of converters are simulated using the parameters listed in Table I.

Figures 5-Figure 7 show the simulation results of the converter closed loop control applying a PI controller.

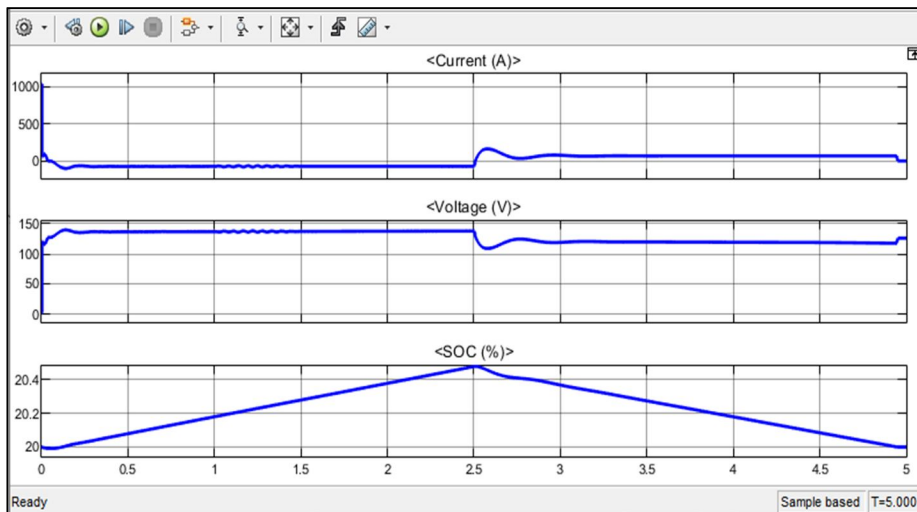

Fig. 5 Waveform of Battery Charge and Discharge

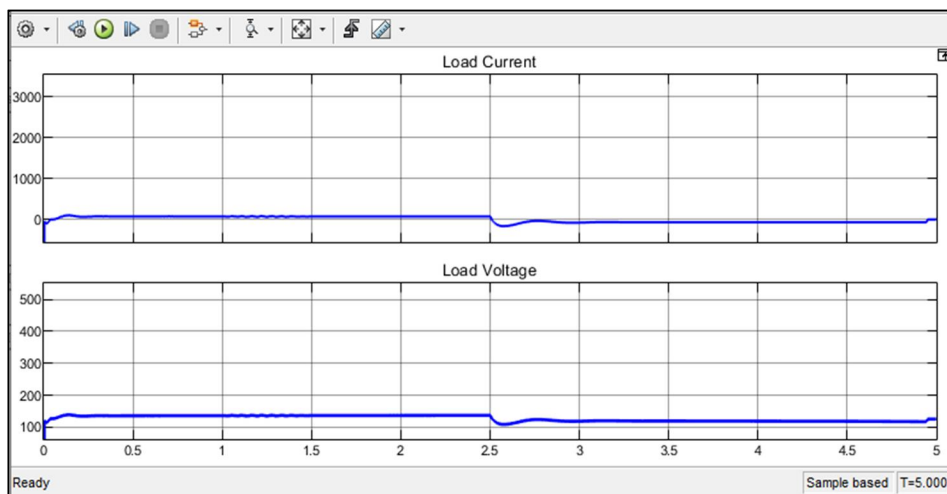

Fig. 6 Load Current and Load Voltage

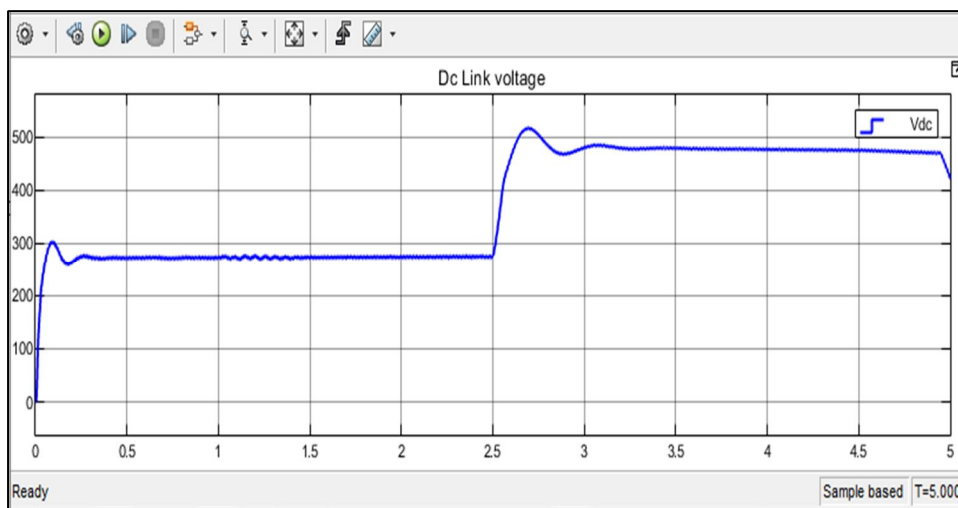

Fig. 7DC-Link Voltage

The simulation results of the converter closed loop control using Fuzzy logic controller are presented in Figure 8-Figure 10.

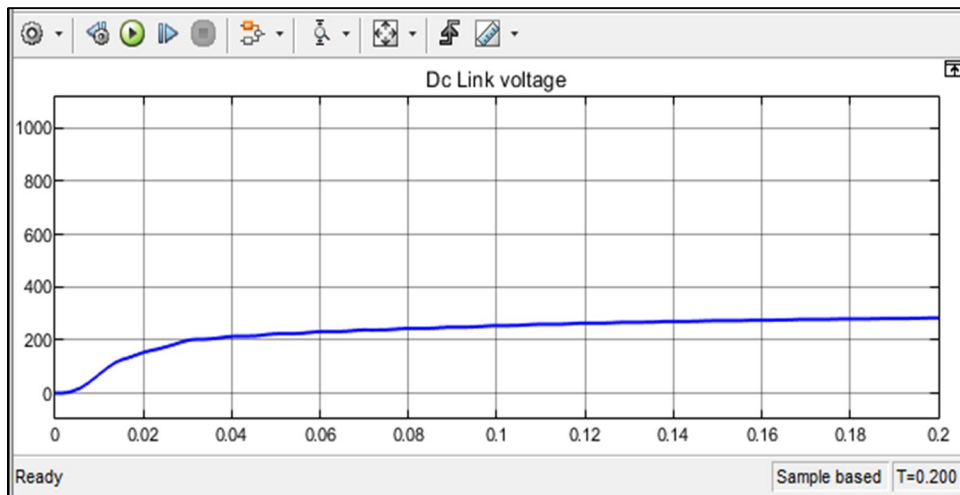

Fig. 8 DC-Link Voltage in G2V mode

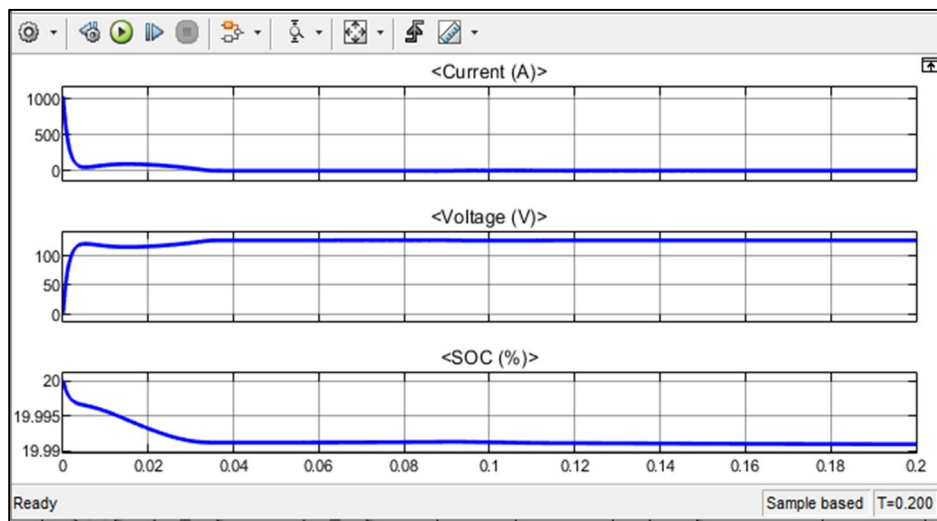

Fig. 9 Waveform of Battery Charge in G2V mode

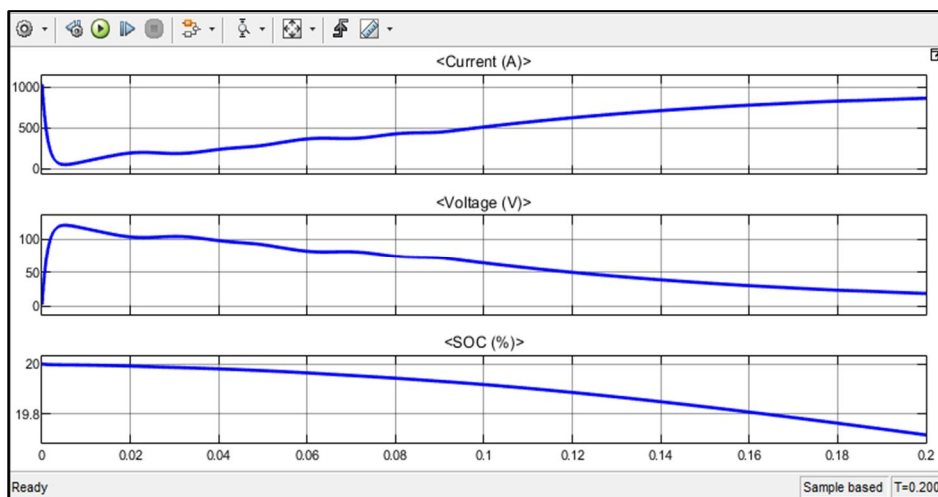

Fig. 10 Waveform of Battery discharge in V2G mode

## VI. COMPARISON OF BIDIRECTIONAL BATTERYCHARGER BETWEEN/ WITH PI CONTROLLER WITH FUZZY CONTROLLER

Table No. II

Controller Used	Rise Time ( $T_r$ ) in sec	Settling Time ( $T_s$ ) in sec	Peak Overshoot ( $M_p$ ) in %	Transient Behavior	Steady State Error (Ess) in %
PI Controller	0.24	0.261	3.03	Oscillatory	26.51
Fuzzy Logic Controller	0.6	0.75	0	Smooth	0

## VII. CONCLUSION

A single phase bidirectional battery charger for EV with PI and Fuzzy controller topology are studied above. From the above observation and analysis of simulation outputs and analysis we conclude that, the FLC is more stable, has less overshoot, and responds quickly. The single-phase bidirectional battery charger has supplied the ac current from the grid at unity power factor which helps to save the life of converter. There are two stages of power converter in charger first stage ac-dc converter and second stage is dc-dc buck boost converter. As ac-dc converter is proposed for energy storage. A new power flows between the low-voltage battery and ac grid where energy transfers from the battery and the grid. Transfer of power carried out between G2V and V2G with active power control.

## REFERENCES

- [1] Mithat C. Kisacikoglu, Metin Kesler, Leon M. Tolbert, Single-Phase On Board ELECTRIC VEHICLE Charger for V2G Reactive Power Operation, IEEE Transaction on Smart Grid Year, Journal Article IEEE, Issue 2, 2015, Volume : 6.
- [2] Kang Miao Tan, Vigna K. Ramachandaramurthy and Jia Ying Yong, "Bidirectional Battery Charger for Electric Vehicle", IEEE Innovation smart grid technologies, Publisher IEEE, Conference Paper 2014, pp. 406-411.
- [3] Lakkireddy Sirisha<sub>1</sub>, T. L Sumitha<sub>2</sub>, "Bidirectional AC/DC Converter with Reduced Switching Losses using Feed Forward Control", Volume 4 Issue 5 May 2015.
- [4] Pavan Singh Tomar, Manaswi Srivastava, and Arun Kumar Verma "A Improved Bidirectional dc/dc Converter with Split Battery Configuration for Electric Vehicle Battery Charging/Discharging," MNIT Jaipur IEEE 2018.
- [5] Pavan Singh Tomar, Manaswi Srivastava and Arun Kumar Verma, "An Efficient Bi-directional DC/DC Charger for Electric Vehicle Battery Charging," IEEE, 2018.
- [6] M. C. Kisacikoglu, M. Kesler, and L. M. Tolbert, "Single-phase on-board bidirectional PEV charger for V2G reactive power operation," IEEE Trans. Smart Grid, vol. 6, no. 2, Mar. 2015 pp. 767-775.
- [7] J.Y.M. Cheung, A.S. Kamal, "Fuzzy Logic Control of refrigerant flow", UKACC International Conference on Control '96, Conference Publication No. 427, September 1996, pp. 2-5.
- [8] Hongfei Wu, Lei Zhu, and Fan Yang, "Three-Port-Converter-Based Single-Phase Bidirectional AC-DC Converter With Reduced Power Processing Stages and Improved Overall Efficiency," IEEE Transactions On Power Electronics, Vol. 33, No. 12, December 2018, pp. 10021-10026.





10.22214/IJRASET



45.98



IMPACT FACTOR:  
7.129



IMPACT FACTOR:  
7.429



# INTERNATIONAL JOURNAL FOR RESEARCH

IN APPLIED SCIENCE & ENGINEERING TECHNOLOGY

Call : 08813907089  (24\*7 Support on Whatsapp)