



IJRASET

International Journal For Research in
Applied Science and Engineering Technology



INTERNATIONAL JOURNAL FOR RESEARCH

IN APPLIED SCIENCE & ENGINEERING TECHNOLOGY

Volume: 9 Issue: IX Month of publication: September 2021

DOI: <https://doi.org/10.22214/ijraset.2021.37960>

www.ijraset.com

Call:  08813907089

E-mail ID: ijraset@gmail.com

Literature Review on Fatigue Life Analysis of Railway Track Incorporating Effect of Load Sequence

Krishnaveni Chevva¹, Naga Mohan Pasupuleti²

¹PG Student, Structural Engineering, Civil Engineering Department, Vidya Jyothi Institute of Technology, Hyderabad, India.

²Asst. Prof., Civil Engineering Department, Vidya Jyothi Institute of Technology, Hyderabad, India.

Abstract: As the railways are the prime mode of transportation, it is extensive to concentrate on railways which increase the economic growth of the country. Considering that the railway traffic system has an enormous influence on the people, the strength reliability of those components is a very important matter related to the safety and safety of the people. As for the strength reliability, one amongst the important study themes is that the strength or fatigue characteristic of every railway component that's subject to repeated loads during use. The reason why it is necessary to consider the fatigue characteristic carefully is that fatigue is a microscopic fracture caused by the initiation and propagation of a crack due to a cyclic slip deformation of the scale of single grain, that fatigue occurs even under a stress smaller than the strength characteristic under a static load (e.g., tensile strength), which it can suddenly result in a fatal fracture without causing any macroscopic plastic deformation and also causes derailment. The literature survey carried out talks about the ideal model for studying dynamic response of railway track, linear and non-linear approaches to find the fatigue life of railway track, crack initiation and propagation, inspection interval for cracks. The literature survey carried out in this paper gives a fair idea about the research gap and thus motivates researchers to carry out future research on the gap found.

Keywords: Fatigue life, shear springs, dampers, literature survey, Rain-flow counting method, non-linear damage accumulation, linear mechanics approach, head checks crack and squat crack.

I. INTRODUCTION

Railways are the prime mode of transportation in almost every country. They have been developed to boost the infrastructure required for industrial, agricultural, socio-economic development as well as transferring passengers at the optimum costs. Railways are preferred due to safety, speed and comfort. From the last three decades, rail transport has been improved in the condition, strength and activity by supplying faster, cheaper, more frequent and more reliable connections both in passenger and freight traffic. However increased traffic density, higher speeds and higher axle loads have their specific effects on the wear of track.

Due to the repeated passing of wheels over the rails, rolling contact fatigue cracks may appear on the surface of the rail. These cracks, such as squats and head checks, can propagate and lead to rail fracture and derailment causing both losses of lives and loss of revenue in terms of disruption of services, damage of assets etc. Two main physical processes that can govern the development of rolling contact fatigue defects are crack initiation and crack propagation of rails. These are intern governed by the factors like rail wheel profiles, track geometry errors, environmental conditions and many others. Therefore heavy monitoring and thorough inspection are needed for the fatigue of rails to avoid catastrophic failures. Thus the infrastructure maintenance people have a very important role to play in taking effective maintenance decisions after proper checking and inspection. If these issues are addressed properly, inspection and maintenance decisions can reduce the potential risk of rail breaks and derailments. Better estimation of fatigue crack propagation of rails and a residual lifetime of rails leads to cost-effective inspection.

A. Railway System Terminology

The word 'system' refers to several interacting parts, each of which performs a specific role. The railway system consists of the following subsystems:

- 1) **Vehicle Subsystem:** Trains are typically referred to as vehicle consists of two kinds of vehicles: a locomotive or power car that permits the train to operate; and wagons that carry goods of some kind. Modern locomotives are usually powered by electricity (in-rail or overhead power), or diesel (mechanical, hydraulic or electric). To investigate rail track forces, vehicles are often defined by the number of axles they have. This research has focused on wagons with two double axle bogies. A typical freight wagon is consists of a car body and bogies.

The Car Body is best defined as a container for goods, whether they are human or material. Vehicle motions are defined in terms of the vehicle and track's vertical, lateral and longitudinal axes. The basic modes of oscillation are:

- a) Pitch; forward and backward rotation about the transverse axis;
- b) Bounce; up and down movement along the vertical axis;
- c) Yaw; rotation about a central vertical axis;
- d) Lateral; movement side to side along the lateral axis; and
- e) Roll; tipping side to side about the longitudinal axis.

In the presented study only bounce and pitch motions of the car body are considered.

The Bogie is that the part that guides the train on the rails and provides stable operation. There are two main sorts of bogies, one with and therefore the other without primary suspension. Suspension is usually manufactured from coil springs that minimize the impact and enhance the steadiness of wagon operations. The bogie incorporates various springs and dampers to cushion the ride. The terminology wont to describe the components of a typical bogie is shown in Fig. 1.1.

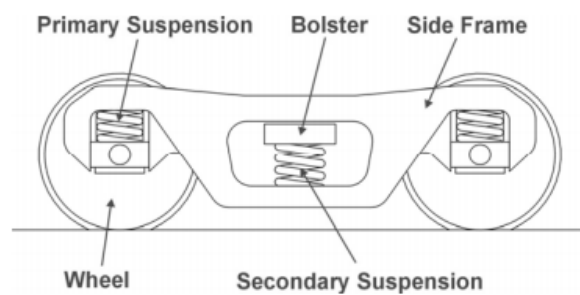

Fig.1 Typical bogie components (Steffens 2005)

The most common variety of bogie wont to transport freight is termed a Three-piece Bogie because its frame has three basic parts: a bolster and two side frames as shown in Figure 1.2. Three-piece bogies are the most cost-effective to buy and most economical to take care of. However, they supply a low level of lateral stability and poor ride quality. This can be mainly due to having only secondary suspension creating the next unsprung mass.

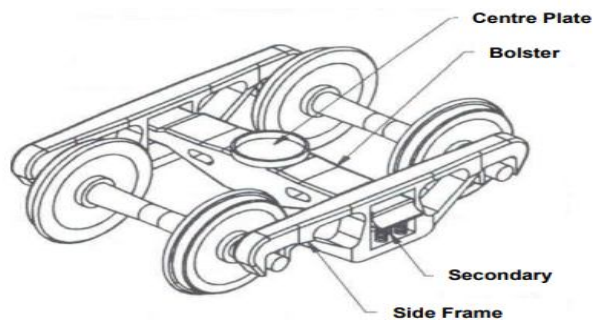

Fig.2 Three piece bogie (Steffens 2005)

Fig. 1.2 shows a typical three-piece bogie. Load from the vehicle is applied through the Centre Plate, where longitudinal or lateral relative movement is fixed. The load is then transferred to the Bolster which spans between the 2 side frames and rests on secondary suspension. The Secondary Suspension which is typically a group of resilient coiled springs then takes the load and transfers it to the Side Frame. In three-piece bogies, the side frames sit directly on top of the axle boxes or package bearing adaptors and tie the two wheelsets together longitudinally. Bogies used for passenger trains usually have Primary Suspensions like a spring, airbag or rubber positioned between the axles of the wheelsets and therefore the side frames. By including primary suspension the lateral stability of the wagons and therefore the ride quality will be significantly improved. This is often due to the lower unsprung mass because the size of the unsprung mass directly relates to the quantity of force transferred into the car body and track from wheel or track irregularities.

The Wheelset is that the assembly consisting of two wheels and bearings on an axle. The two wheelsets at each end of the vehicle are fitted to the bogie which might yaw to negotiate curves.

2) **Track Subsystem:** The track is that the base upon which the vehicle runs and also the steering base for the train. Track form consists of generally the two steel rails, secured on sleepers to stay the rails at the correct distance apart (the gauge) and capable of supporting the weight of trains, ballast and subgrade. The ballasted track is that the most typically used nowadays, that the present study are going to be specializing in the ballasted track structure as shown in Fig. 1.3.

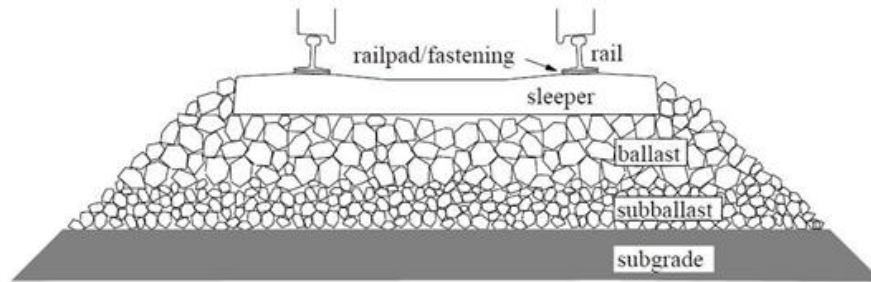

Fig.3 Track with different components (Steffens 2005)

The main components of ballasted track structures are also grouped into two categories: superstructure and substructure. The superstructure consists of the rails, fasteners and pads, and therefore the sleepers. The substructure consists of the ballast, the subballast (capping layer) and also the subgrade (formation).

Rails are the longitudinal steel members that directly assist the train wheels evenly and continuously. They need to have sufficient stiffness to function beams that transfer the concentrated wheel loads to the spaced sleeper supports without excessive deflection between supports.

Fasteners are typically required to retain the rails on the sleepers and to resist vertical, lateral, longitudinal and overturning moments of the rails. The force systems causing these movements are from the wheels and also the temperature within the rails.

Rail Pads or Plates are required between the rail seat and also the sleeper surface to fulfil various functions. These include providing resilience for the rail-sleeper system, damping of wheel-induced vibrations, and reduction of rail-sleeper contact attrition.

Sleepers are essential beams that span across and tie together the two rails. They need several important functions including receiving the load from the rail and distributing it over the supporting ballast at an appropriate ballast force per unit area, holding the fastening system to maintain proper track gauge, and restraining the lateral, longitudinal and vertical rail movement by anchorage of the superstructure within the ballast. Additionally, sleepers provide a cant to the rails to assist develop proper rail wheel contact by matching the inclination of the conical wheel shape.

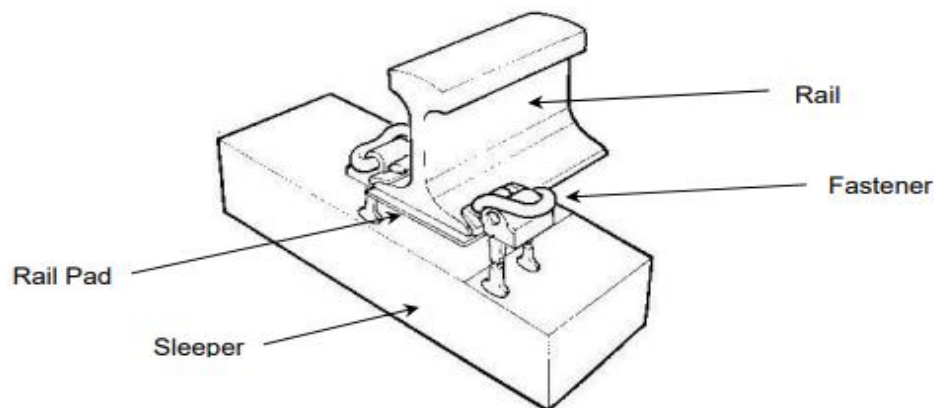

Fig.4 Concrete sleeper fastening system (Steffen 2005)

Ballast is the layer of crushed stone on which the sleepers rest. The ballast assists in track stability by distributing load from the sleepers uniformly over the sub-grade. It anchors the track in place against lateral, vertical and longitudinal movement by way of irregular-shaped ballast particles that interlock with each other. Any moisture introduced into the system can easily drain through the ballast away from the rails and sleepers. The coarse-grained nature of ballast assists in track maintenance operations due to its easy manipulation. The rough interlocking particles also assist in absorbing shock from dynamic loads by having only limited spring-like action.

Subballast is also known as the Capping Layer is usually a broadly graded material that assists in reducing the stress at the bottom of the ballast layer to a tolerable level for the top of the subgrade. The sub-ballast is usually an impervious material that can prevent the interpenetration of the subgrade and ballast, thereby reducing migration of fine material into the ballast which affects drainage. This layer also acts as a surface to shed water away from the subgrade into drainage along the side of the track.

Subgrade has also known as the Formation, offers the final support to the track structure. The subgrade bears and distributes the resultant load from the train vehicle through the track structure. The subgrade facilitates drainage and provides a smooth platform, at an established grade, for the track structure to rest upon.

II. LITERATURE REVIEW

A. Literature on Vehicle-Track Interaction

The dynamics of railway tracks because of moving trains attracted many researchers to research the matter employing a theoretical approach. The rails were idealized as beams of infinite extent supported by the elastic foundation, that classical solutions are available in textbooks by Hetenyi (1958) and Timoshenko (1947). Later on, several authors incorporated complex train track dynamic interaction where rail irregularity was given due consideration.

Yadav and Upadhyay (1991) presented an analytical approach of train track foundation vibration for a vehicle moving with a variable velocity over a flexible track, and therefore the track is finite length, uniform cross-section and its meaning is described by a determinate function while the random unevenness is modeled by power spectral density function, can have first or/ and second-order non-homogeneity. The vehicle is modeled as two degrees of freedom as lumped masses with linear springs and dampers. The equation of motion is coupled into generalized coordinates for lumped masses and track mode shapes; the analysis yields closed-form expressions for the second-order statistics of the response.

Yadav and Upadhyay (1992) extended their one-point input models to two-point input models with heave-pitch and heave-roll degrees of freedom. For the analysis, the vehicle suspension and foundation stiffness and damping characteristics are idealized to be linear. Velocity can be variable over time. The two-wheel paths then the heave-roll model may have differences in unevenness. Obtained the closed-form expressions for the system, and stated that the vehicle sprung mass behaviour is predicted to vary by these models, indicating that the strong effect of coupling on the vehicle vibration.

Cai and Raymond (1992) reported a track dynamic interaction model consisting of 1 bogie. The wheelset model included two unsprung masses, side frame mass and pitch inertia, and first suspensions. The track was modeled as a 40-sleeper long discretely supported system of elastic beams representing the rails and also the sleepers. This model was used to examine the dynamic response because of various wheel and rail defects. It absolutely was found that the wheel and rail impact behaviour depends highly on the train speed, and it had been also found that a wheel with an irregular profile causes not only a high impact force on itself, but also greatly increases the impact force on the adjacent wheel.

Zhai and Sun (1993) presented a model that represented the wagon as two bogies multi-body system and also the track as an infinite Euler beam supported on a discrete-continuous elastic foundation consisting of three layers of rail pad, sleeper, and ballast. The importance of the mutual dynamic influence of the neighbouring wheelsets via the rail and therefore the bogie was determined within the paper.

Dahlberg (1995) reported a theoretical model almost like that of Cai and Raymond (1992) with one bogie and track to model the field experiments. This model was used to investigate the sensitivity of the parameters like the wagon speed, the axle load, the wheelbase of a bogie, the defects in rail and wheel on the dynamic behaviour of the track and wagon components.

Ripke and Knothe (1995) developed a model the same as that of Zhai and Sun (1993) but used the Timoshenko beam formulation to model the rail and sleepers rather than the Euler formulation. This model was used to investigate the results of the local defects of the track on the contact forces.

Zai and Cai (1995) describe the formulation and application of a numerical model that simulates the vertical dynamic interaction between a training vehicle and a track. The considered vehicle model has 10 degrees of freedom lumped mass system comprising of auto body mass and its moment of inertia, the 2 bogie mass and their moment of inertia and 4 wheelset unsprung masses. The bogie and wheels are connected with primary suspension and vehicle body and bogie are suspended with secondary suspension within the track model, the track is treated as infinitely long beam discretely supported at rail sleeper junctions by a series of springs, dampers and much-representing elasticity and damping effects of the rail pad, ballast, subgrade, respectively. Shear springs and dampers are introduced between the ballast masses to model the shear coupling effects within the ballast. The dynamic interaction between the wheelsets and therefore the rail is accomplished by using the nonlinear Hertzian theory. This model investigated the effect of speed on the dynamic response of rail and quantified the dynamic wheel/rail load.

Fermer and Nielsen (1995) reported a full-scale experiment carried on the West Coastline in Sweden using a wagon equipped with instrumented wheelsets at speeds up to 275 km/h. five successive sleepers and one rail instrumented with accelerometers and strain gauges were used. The impact of wagon speed and axle load on dynamic responses was studied. It had been concluded that the pad stiffness and therefore the axle load largely affected the contact forces because of wheel flats.

Frøhling et al. (1997) investigated a more detailed controlled field test conducted in South Africa. The objective of the test was to understand the possible detrimental effects caused by the low-frequency contact forces. It was come to an end that the track dynamic responses were affected by the vehicle load, the vehicle speed, the track geometry, the track stiffness, and the accumulating traffic.

Sun and Dhanasekar (2000) developed a dynamic model to examine the vertical interaction of the rail track and the wagon system. Wagon with four wheels sets representing two bogies is modeled as 10 degrees of freedom subsystem, the track is modeled as a four-layer subsystem and two subs systems are coupled together via the non-linear Hertzian contact mechanism. The developed model has been validated using four sets of data reported in the literature. Stated that the model is capable of predicting the influence properties of the rail track and the wagon components on the impact forces and other dynamic responses of the rail track and wagon system.

Kumaran et al. (2003) presented a 3D mathematical model, including the vehicle(with 17 degrees of freedom) and track structure is investigated, considering vehicle suspension system, speed, wheel and rail irregularities and elastic properties of the rail pad and ballast-subgrade. The common imperfections, due to rail joints, wheel flatness and track unevenness, have been considered in the dynamic input to the vehicle model. The damping characteristics of the track and railway vehicle have also been considered. The effect of the semi-infinite medium of the subsoil is considered by imposing the silent boundary conditions at the base of the horizontal ballast of the finite model. The dynamic interactive analysis is carried out between the vehicle and the track in the time domain using MSC/NASTRAN finite element software. The results of the interactive analysis give responses in the form of reaction time histories at the rail seat locations during the passage of the vehicle. Presented dynamic amplification factors for the deflection, ballast pressure and bending moments have been evaluated at the critical section (rail seat and Centre) for various exciting frequencies under the different vehicle-track parametric conditions.

Vivek and Vikas's (2009) vertical dynamic analysis was carried out for a typical Indian railway vehicle of AC/EMU/T (alternating unit/electrical multiple unit /trailer) types running on broad gauge. 17 degrees of freedom (3D model) was used for analysis to found the vertical acceleration of the car body at C.G in the frequency domain and compared the results obtained with the standards set by the Indian Railways.

Anyakwo (2012) presented a new method for modelling and simulation of wheel-rail contact contains wheel-rail geometry results the efficient solutions for normal and tangential contact problem representing the wheelset dynamic behaviour on the track. The lateral displacement of the wheelset and the yaw angle is taken into account. The mathematical model is implemented in Matlab using the numerical differentiation method and simulated results show that as the forward velocity of the wheelset increases, the wheelset becomes unstable on the track due to increasing lateral oscillations.

Ferrara (2013) presented a 2D model to predict train-induced vibrations, considers mutual interactions in vehicle/track coupled systems utilizing finite and discrete element method, considers the rail defects and case of out-of-round wheels, and non-linear Hertzian contact theory is used for interaction between rail and wheelset. The rail-sleeper contact is assumed and extended to an area-defined contact zone, rather than a single point assumption which fits better real case studies.

Rakesh (2014) presents 37 degrees of freedom coupled vehicle-lateral model of Indian Railway vehicle formulated using Lagrangian dynamics to seem at its dynamic behaviour. The 37 coupled vertical –lateral motion equations are further used to report the ride behavior of Indian Railway general sleeper and Rajdhani coach.

Liang Ling (2014) A 3D dynamic model of a high-speed train plus a flexible track is shown during this model each vehicle is modeled as forty-two degrees of freedom multi-body system, which takes into consideration the nonlinear dynamic characteristics of suspension, an in-depth inter-vehicle connection model including nonlinear couplers and inter-vehicle dampers, and so the linear tight-lock vestibule diaphragm is established to simulate the effect of the end connections of neighboring vehicles on dynamic behaviour, and also the track is modeled as a regular three-layer discrete elastic support model and also the rail is assumed to be Timoshenko beams supported by discrete sleepers. The very fact of this model is validated through a detailed numerical simulation comparison with the commercial software SIMPACK, with the effect of track flexibility on the train/track interaction. The numerical results of this model show that there is an enormous difference between the dynamic behaviour obtained by the single-vehicle track model and so the whole train track model which interconnections have a really important influence on the dynamic behaviour of high-speed vehicles.

B. Literature on Fatigue of Rails

The concentration on fatigue has been started from the railway accident to cause a major death toll, which occurred near Versailles in 1842 when the axle of a locomotive broke. During the next two decades, the great German railway engineer Wöhler demonstrated that cyclic stress ranges determined fatigue lives and that for steels at least, fatigue limiting stress existed, below which fatigue lives were infinite. The S/N curve, relating stress range to cycles to failure and the fatigue limit, remains the basis of design against classical fatigue.

Miner (1945) used the S-N curve approach to formulate a linear damage accumulation rule, which enabled one to predict fatigue damage at each incremental stress range. Later on, Miner's linear damage hypothesis has found several applications in studies related to fatigue damage assessment.

Wrishing et al (1982) presented a basic terminology associated with random process theory related to fatigue life. They described Palmgren-Miner's rule and gave statistical summaries, which describe the performance of the miner's rule. Finally, methods of predicting fatigue crack growth under variable stresses are reviewed.

Hay (1982) reviewed the types of rail defects that lead to broken rail service failures and derailments. Defects are divided into four groups: longitudinal defects, transverse defects, base defects, and other defects. He stated that the most dangerous type of rail defects are transverse fissures that initiate inside the railhead due to minute shatter cracks and then expand across the railhead due to cyclic loading until the rail breaks, often with little or no prior indication of the weakened condition. He also examined surface defects that arise from contact and shearing stresses. These include head checks, squats, flaking, and shelly defects.

Sperry Rail Service (1999) published a guide to assist railroads with rail defect management and identification. The manual is divided into sections explaining each type of possible rail defect. The categories of rail defects that the authors defined are transverse defects, longitudinal defects, web defects, base defects, damaged rail, nicked rail, surface defects, and miscellaneous defects. The guide stated, "The growth of a rail defect depends on a great many variables. The chemical composition of the rail and the amount of rail flexing are factors that must be considered. The type of rolling stock (freight, passenger, or motive power), its weight, and its condition of repair is important, as well as the frequency of these loads. The conditions of the roadbed and weather changes that result in track movement also affect growth. With so many variables contributing to development, it is impossible to predict accurately the growth of any defect."

Smith (2005) Smith stated that the quality of steel manufacturing has improved over the last 30 years, thus eliminating many fatigue failures from internal defects in the railhead; instead, a large proportion of rail failures are now occurring at weld locations. He also found that the life of a rail is principally determined by wear at the railhead. The wear can lead to shape change along the length of the rail, which in turn produces greater stresses in the wheel-rail contact. The author stated that rail grinding can be used to remove corrugations and to restore the accurate rail head profiles that are essential for controlling these stresses.

Da Silva et al. (2003) performed tests on newly manufactured rail to determine fatigue crack growth rate. Four sheets of steel were each tested under stress with temperature and humidity maintained at a laboratory level. To determine fatigue crack growth, manual measurements of surface cracks were recorded at regular intervals. The tests showed that regression analysis could be used to model the crack growth in each of the specimens. Additionally, by examining the regression, three different states (stage I, stage II, and stage III) of crack growth can be identified in steel. Found that crack growth is difficult to predict because in stage III, crack growth can accelerate, remain steady, or slow down. The authors concluded there was no significant difference in the crack growth rates in the samples from the four different manufactures.

Kim & Kim (2002) completed a study examining the fatigue behaviour of rail steel under mixed loading levels. To simulate the effect of mixed loadings in the laboratory, the fatigue crack growth behaviour was evaluated using various comparative stress intensity ranges. The results of this analysis were compared to the testing completed under constant stress. Specifically, he examined the transition from shelling to a transverse crack under mixed-mode loadings. Finite element modelling was used to analyze the effects of the wheel/rail interface. The authors determined that internal cracks first grew in the longitudinal plane and turned into transverse cracks. The authors also concluded that fatigue crack growth rate under mixed loading conditions was slower than that under constant load.

Fletcher et al. (2004) completed an examination of rails within which large rolling contact fatigue cracks had developed. He focused on the interaction between adjacent long cracks, a minimum of 10mm length that's at the start of their bending stress-driven propagation phase. He developed a model that supported the boundary element technique for the expansion of adjacent long cracks. The results of the analysis were shown in an exceedingly series of plots of stress intensity factors around crack fronts for both single and multiple-crack situations. The conclusions reached in their study were that the previous models of single-crack growth are misleading when managing a rail containing multiple adjacent cracks.

Fischer et al. (2006) studied the expansion and behaviour of surface cracks on railway tracks under load. He considered the case of a shallow angle surface crack that will propagate either parallel or perpendicular to the surface of the rail. This case was tested for various strain and stress states. He found that little surface cracks are common but generally experience slow crack growth. However, some surface cracks were found to grow up to a few millimetres length, so change their direction towards the rail surface and also concluded that this deviation occurs at a crack length where the stress intensity ranges reach a threshold where the tensile residual stress is sufficiently large to vary the direction of the crack.

Mutton et al. (2009) measured the longitudinal bending stresses at the underhead position at several track locations subjected to high axle load rail traffic. In his study, the strain gauges were applied to the relevant position on the welds, and on the corresponding position on the rail at a distance of roughly 1200 mm away from the instrumented welds, within the direction facing the approaching loaded traffic. It had been found that the tensile bending stress at the gauge-side underhead radius of the rail reached a peak value of about 100 MPa when the wheel was directly above the gauge position (underhead offset of measurement point 20 mm). The relative stresses on the field-side underhead radius of the rail reached a maximum value of about 83 MPa. For various wheels of 1 train, the magnitude of the maximum tensile stress varied considerably at both gauge and field-side underhead radius positions of the rail.

Ranjha et al. (2011) used finite element software ABAQUS to test the strain state at the underhead radius and gauge corner of the rail, concluded that tension spike at the underhead radius was found to be highly influenced by several factors; the extent of offset of the contact patch, the ratio of lateral to the vertical loads, the direction of lateral traction, vertical stiffness and seasonal temperature. Found that longitudinal tensile stresses increased at the underhead radius because the vertical foundation stiffness increases and tensile stresses increase in cold months and reduce in hot months.

Zdenka Popović, Vlatko Radović (2016) presented maintenance problems because of the looks of rail defects observed on the Serbian Railways and also the Railways of Montenegro. The authors highlighted the importance of grinding strategies against RCF rail defects and preventive activities removal of more or less severe defects and cyclical activities during the entire rail service life. They calculated the influence of wheel load, rail crown radius and traction on shear stresses and Hardness distributions in standard carbon rails in tangent track at different axle loads. And concluded that increased traffic density, axle loads and speed furthermore as lubrication of rails are contributors to the current problem may be reduced by correct track geometry, correct wheel/rail contact patch geometry, improved maintenance.

Jay Prakash Srivastava, et al. (2017) performed a three-dimensional elastic-plastic finite element analysis to estimate the rolling contact fatigue initiation life for diverse slip range on the rail coming from operational variations. For the prediction of RCF life considered the combined effect of contact pressure and/or traction or frictional heat in isolation together by translating the wheel load on the rail for multiple (twelve) passes. Used coded search algorithm to spot the critical plane of crack initiation relative to the utmost fatigue parameter. The Hertzian theory is taken into account for contact dimension and pressure distribution. Authors focused on exploring the consequence of non-proportional cyclic loading in terms of fixing stress/strain amplitudes liable for crack initiation. And they concluded that, the partial slip condition greatly influences the strain and strain distribution for a thin layer (up to five mm) of material beneath the contact interface. The influence of variation in rolling-sliding contact condition represented by normalized tangential traction parameter ζ with different values shown that these conditions liable for fatigue to originate from the outer surface or a subsurface point.

R. Masoudi Nejada, et al. (2018) used a rail available in Iran railway with a precise profile geometry taken to investigate the rolling contact fatigue at risk of residual stresses caused by the contact between the wheel and rail and its manufacturing process. The location of maximum stress caused by the contact of wheel/rail for rail profiles are often calculated by a 3D elastic-plastic finite element model and to estimate the stress distribution within the rail manufacturing process, thermal analysis with a finite element method had performed stress analysis are going to be used as inputs for three-dimensional crack growth and rail fatigue life estimation model to calculate the stress intensity factors and fatigue life in keeping with a set of parameters associated with the boundary element method. Concluded that residual stresses caused by the manufacturing process had a major effect ends up in crack deviate from the main path. Initial crack length plays a very important role in fatigue life specified the less this initial length is, the more the fatigue life are going to be. Increase within the initial angle of crack propagation. The higher the crack length is, the more probable it's for the crack to become deeper. Fatigue life for surface cracks in rail is below that for cracks in railhead or rail web. It is often concluded that because the crack length increases, fatigue life decreases.

P.A.K. Karunananda, et al. (2019) analysed the fatigue damage lifetime of a significant bridge in state by Miner's cumulative damage of fatigue life. The remaining lifetime of the railway bridge followed a replacement damage indicator using the sequential law under increased live loads and it compared with Miner's rule. And conclude that the appliance of the sequential law-based

proposed approach is advisable for the evaluation of the remaining fatigue lifetime of riveted railway bridges where the detailed stress histories are known.

E A Shur, et al. (2020) applied experimental studies of the residual static strength of rails with transverse cracks within the head. The transverse cracks were detected by means of flaw detection in railway tracks. The average values of the relative area of the crack and therefore the breaking load is determined. The methodology was developed on the premise of fractographic analysis and studies of macro line fatigue in a very crack that developed in an exceedingly rail on a single-track section with a regular change within the direction of train movement. A linear part of the graphic dependence of the crack rate of growth on the most value of stress intensity factors (Paris diagram) for rails under real operating conditions was calculated. As a result, a linear part of the dependence of the crack rate of growth on the maximum value of stress intensity factors (Paris diagram) for railway rails in real operating conditions was constructed, which may be accustomed verify the relevant calculations.

III.OBJECTIVES OF THE STUDY

- A. Development of MATLAB code to perform the dynamic analysis of vehicle-track coupling system by numerical integration.
- B. Estimation of fatigue life of rail using linear damage approach and non-linear damage curve approach.
- C. Estimation of inspection interval of crack growth for safe monitoring of rail.

REFERENCES

- [1] Aglan, H. & Gan, Y.X. (2001). Fatigue crack growth analysis of a premium rail steel. *Journal of Materials Science*, 36(2), 389-397.
- [2] Cai, A., Raymond, G.P., (1994). Modeling the dynamic response of railway track to wheel/rail impact loading. *Struct. Eng. Mech.* 2 (1), 95-112.
- [3] Cheng, S. Y., Au, F. T. K., Cheung, Y. K., (2001). The vibration of railway bridges under a moving train by using bridge-vehicle-track element. *Engineering structures*, 23, 1597-1606.
- [4] Da Silva, L., F., M., Stewardson, D., J., De liveira, F., M., F., (2003). Fatigue crack growth of rails for railways. *Proceedings of the institution of Mechanical Engineers, Part F- Journal of Rail & Rapid Transit*, 217(2), 89-97
- [5] Dahlberg, T., (1995). Vertical dynamic train/track interaction verifying a theoretical model by full-scale experiments. *Vehicle System Dynamics*, 24, 45-57.
- [6] E A Shur, A I Borts and L V Bazanova, (2020). Fatigue life of damaged rails. *Journal of Physics: Conference Series*1431 (2020) 012071.
- [7] Eisenmann, J., Leykauf, G., The effect of head checking on the bending fatigue strength of railway rails. In *Proceedings of International Conference on Rail Quality and Maintenance for Modern Railway Operations*, 373-384, June 1992.
- [8] Fermer, M., Nielsen, J.C.O., (1995). Vertical interaction between train and track with soft and stiff rail pads—full-scale experiments and theory. *Proc. Inst. Mech. Eng.* 209, 39-47.
- [9] Ferrara, R., Leonardi, G., Jourdan, F., (2013). a contact area model for rail-pads connections in 2-D simulations: sensitivity analysis of train induced vibrations. *International journal of vehicle mechanics and mobility*, 1-22
- [10] Fletcher, D.I., Hyde, P., & Kapoor. A. (2004). Growth of multiple rolling contact fatigue cracks driven by rail bending modeled using a boundary element technique. *Proceedings of the Institution of Mechanical Engineers, Part F - Journal of Rail & Rapid Transit*, 218(3), 243-253.
- [11] Fryba, L., (1996). *Dynamics of railway bridges*, Thomas Telford, Czech Republic.
- [12] Fröhling, R.D., Tomas, M., Ebersohn, W., (1997). Low-frequency dynamic vehicle/track interaction: Instrumentation and measurement. In: *Proc. Sixth Int. Heavy Haul Conf.*, Cape Town, South Africa, 462-474.
- [13] Garnham, J., and Beynon, J. H., (1991). The early detection of rolling-sliding Contact fatigue cracks. *Wear* Volume, 144(2), 103-116.
- [14] Grover, H., J., (1960). An observation concerning the cycle ratio in cumulative damage, In; *Symposium of fatigue of aircraft structures*, ASTM STP274, American society for testing and materials, 120-124.
- [15] Hetenyi, M., (1958). *Beams on elastic foundation*. The University of Michigan Press.
- [16] Jay Prakash Srivastava, Prabir Kumar Sarkar V R Kiran Meesala, Vinayak Ranjan, (2017). Rolling Contact Fatigue Life of Rail for Different Slip Conditions. *Latin American journal of solids and structures*.
- [17] Johnson, K. L., (1989). The strength of surfaces in rolling contact. *Proc institution of mechanical engineers*, 203, 151-163.
- [18] Kim, J.K. & Kim, C.S. (2002). Fatigue crack growth behavior of rail steel under mode I and mixed-mode loadings. *Materials Science and Engineering A*, 338(1-2), 191-201.
- [19] Kumaran, G., Devdas Menon, Krishnan Nair, K., (2003). Dynamic studies of railway track sleepers in a track structure system. *Journal of sound and vibration*, 268, 485-501.
- [20] Lei, X., and Noda, N. A., (2002). analyses of the dynamic response of vehicle and track coupling system with random irregularity of track vertical profile. *Journal of sound and vibration*, 258(1), 147-165.
- [21] Liang Ling, Xin-biao XIAO, Jia-yang XIONG, Li ZHOU, Ze-feng WEN, Xue-song JIN, (2014). A 3D model for the coupling dynamics analysis of high-speed train/track system. *Journal of Zhejiang University*, 15(12), 964-983.
- [22] Manson, S., S., Halford, G., R., (1981). Practical implementation of the double linear damage rule and damage curve approach for treating cumulative fatigue damage. *International Journal of Fracture*, 17(2), 1981.
- [23] Metsam, N., Jabbar, A. Z., Morteza, E., Morad, S., (2015). Influence of uneven rail irregularities on the dynamic response of the railway track using a three-dimensional model of the vehicle-track system. *Vehicle system dynamics*, 53(1), 88-111.
- [24] Miner, M. A., (1945). Cumulative damage in fatigue. *Journal of Applied Mechanics*, 12(3), 159-164.
- [25] Mutton PJ, Tan M, Bartle P, Kapoor A. The effect of severe headwear on rolling contact fatigue in heavy haul operations. 8th International conference on contact mechanics and wear of rail/wheel systems (CM2009), Firenze, Italy, 2009.



- [26] P.A.K. Karunananda, H.K.C.U. Herath, W.S. Madusanka, W.M.A.D. Wijethunge (2019). Effect of loading sequence in fatigue life prediction of a 130 years old railway bridge. 10th International Conference in Structural Engineering and Construction Management. At: Kandy, Sri Lanka.
- [27] Paris, P., F. Erdogan, (1963). A critical analysis of crack propagation laws. *Journal of basic engineering*, 85(4), 528-533.
- [28] R. Masoudi Nejada, M. Shariatia; , Kh. Farhangdoosta , and A. Atrianb, (2018). Rolling contact fatigue analysis of rails under the influence of residual stresses induced by manufacturing. *Scientia Iranica (SCI IRAN)* 26(3):1427-1437.
- [29] Rakesh, C., S., (2014). Modeling and simulations of the railway vehicle system. *International journal of mechanical engineering and robotics research*, 1(1), 55-66.
- [30] Ranjha SA, Ding K, Mutton PJ, Kapoor A. Finite element modeling of the rail gauge corner and underhead radius stresses under heavy axle load conditions. *Proceedings of the Institution of Mechanical Engineers, Part F: Journal of Rail and Rapid Transit* 2011, 226(3), 318-30.
- [31] Ripke, B., Knothe, K., (1995). Simulation of high-frequency wagon-track interactions. *Vehicle System Dynamics*, 24, 72-85.
- [32] Smith, R.A. (2005). Railway fatigue failures: an overview of a long-standing problem. *Material wissenschaft und Werkstofftechnik*, 36(11), 697 – 705.
- [33] Sperry Rail Service (1999). *Rail Defect Manual*. Sperry Rail Service, Danbury, Conn.
- [34] Steefens. D., M., Identification and development of a model of railway track behavior. Queensland University of Technology, 2005.
- [35] Sun, Y. Q., Dhanasekar, M., (2002). A dynamic model for the vertical interaction of the rail track and wagon system. *International journal of solids and structures*, 39, 1337-1359.
- [36] Timoshenko, S., (1930). *Strength of Materials, Part II*. D van Nostrand Company, Inc.
- [37] Vivek Kumar, Vikas Rastogi., (2009). Investigation of vertical dynamic behavior and modeling of a typical Indian railroad vehicle through a bond graph. *World journal of modeling and simulation*, 5(2), 130-138.
- [38] Wirsching, P. H., Albretch, P., Artley-dean, M., Ellingwood, B., Sachilling, C. G., and Zetrtlemoyer, N. (1982). Fatigue reliability: variable amplitude loading. *Journal of structural engineering*, 108, 47-69.
- [39] Yadav, D., and Upadhyay, H. C., (1991). Nonstationary dynamics of train and flexible track over inertial foundation during variable velocity runs. *Journal of sound and vibration*, 147, 57-71.
- [40] Yadav, D., and Upadhyay, H. C., (1992). The dynamics of a vehicle in variable velocity runs over non-homogeneous flexible track and foundation with two-point input models. *Journal of sound and vibration*, 156(2), 247-268.
- [41] Zdenka Popović, Vlatko Radović, (2016). Rolling contact fatigue of rails. The III International Scientific and Professional Conference., CORRIDOR 10 – A sustainable way of integrations“ At: Belgrade.
- [42] Zerbst U, Schödel M, Heyder R., (2009). Damage tolerance investigations on rails. *Engineering Fracture Mechanics*, 76:2637-53.
- [43] Zhai, W., and Cai, Z., (1995). Dynamic interaction between a lumped mass and a discretely supported continuous rail track. *Computers and Structures*, 63(5), 987-997.
- [44] Zhai, W., Sun, X., (1993). a detailed model for investigating the interaction between railway vehicles and track. In: *Proc. 13th IAVSD Symp*, 603-614.



10.22214/IJRASET



45.98



IMPACT FACTOR:
7.129



IMPACT FACTOR:
7.429



INTERNATIONAL JOURNAL FOR RESEARCH

IN APPLIED SCIENCE & ENGINEERING TECHNOLOGY

Call : 08813907089  (24*7 Support on Whatsapp)