



IJRASET

International Journal For Research in
Applied Science and Engineering Technology



INTERNATIONAL JOURNAL FOR RESEARCH

IN APPLIED SCIENCE & ENGINEERING TECHNOLOGY

Volume: 9 Issue: IX Month of publication: September 2021

DOI: <https://doi.org/10.22214/ijraset.2021.38042>

www.ijraset.com

Call:  08813907089

E-mail ID: ijraset@gmail.com

Seed Sowing Robot

Dr. D. A. Godse¹, Mayuri Bhosale², Pratibha Balge³, Aditi Thorat⁴

^{1, 2, 3, 4}Department of Information Technology, Bharati Vidyapeeth's College of Engineering for Women, Katraj, Pune, INDIA

Abstract: Agriculture is the most important field for human beings. It is the backbone of our country's economic system. Equipment that needs less human effort and time with less price of implementation is way needed for fulfilment within the agricultural trade. Project work is focused on the seed sowing process and the design of a four-wheel-drive robot that does the work of seed sowing in plowed agricultural land avoiding the human effort by tracing the path and sowing seeds and tried to solve the problems related to agriculture. Seed sowing robot consists of battery-powered wheels, a DC motor inbuilt in these wheels, an Arduino Uno is useful for controlling the robotic activities. The Robot can detect the obstacle very easily with the help of an ultrasonic sensor. In every complete rotation of the rotating wheel, there's a seed fall from the seed drum and performs seed sowing operation.

Keywords: Agriculture, Farmer, Seed, Robot

I. INTRODUCTION

Most of the country's area unit plagued by inadequate labor and power provide particularly within the field of agriculture. Different operations are performed in farming they are seed sowing, cutting, spraying fertilizers, and weeding. The most significant task is sowing seeds in an agricultural field. Sowing is the most important process in farming and a time-consuming process. The design of a seed sowing robot automates the task. In standard ways, the method of sowing is incredibly troublesome and inconvenient to perform. In most of the country's tractors are used for performing sowing operations in an agricultural field. It causes pollution and consumes large power that can be decreased with this system. The development of advanced technology within the field of farming is far required, particularly seed sowing in terms of proving row to row spacing, seed to seed spacing which ends in an exceedingly higher yield. Automation in agriculture is still in the developing stage due to a lack of technical knowledge, advanced technology, and machinery. Hence victimization of the new technology in farming activity might give larger support to the farmers.

II. LITERATURE SURVEY

The sowing of seeds is an important part of crop production. Several techniques are being utilized by the farmers for seed sowing, which includes the traditional methods of broadcasting manually, dibbling, and line sowing [1]. There are various methods that are used in agricultural fields for various operations which are performed in the agricultural field. Some of them are cost-effective but require manpower. In [2], the author states that traditional seed sowing includes broadcasting manually, opening furrows by a country plough and dropping seeds by hand, dropping seeds in the furrow through a bamboo/meta flannel attached to a country plough and for sowing in small areas is a difficult task. With the idea of the automatic seed sowing process, including sensors, devices, robots, machines, and information technology, the process can be more reliable for monitoring and management of agricultural activities. The purpose of seed sowing is to put the seeds into the soil in rows at desired depths and spacing, followed by covering the seeds with soil and providing proper compaction over the seed, hence leading to their germination which is explained in detail in this paper [2]. The movement of the robot is controlled by the Arduino through the L298N motor driver based on the inputs given and, on the path, it has to take motors used are DC geared motors. The motors are driven by the motor drivers to make sure all the motors will have an equal distribution of power [3]. The wheels are not directly connected to the shafts of the motors but the gear is being used as a connector to drive the wheels using motors. Arduino Uno is the heart of the system which is connected with all the sensors and other hardware assembly required to achieve the desired work. In [4], the author explained features of Arduino Uno that it is a small, complete, and breadboard-friendly board based on the ATmega328. A Servo motor is used for dispensing the seeds. A servo motor is a self-contained electrical device that rotates parts of a machine with high efficiency and with great precision [4]. After each rotation of the servo motor, the seed gets dispensed into the soil. There is one bent that covers up the seed through the soil after dispensing. The construction of Fuzzy Logic Systems is straightforward and graspable. Fuzzy logic comes with mathematical ideas of pure mathematics and therefore the reasoning of that's quite straightforward. It provides a very efficient solution to complicated issues in all fields of life as it resembles human reasoning and deciding. The important task of the robot is Obstacle Detection.

Obstacle detection is the primary demand of this autonomous robot. The robot gets the information from the surrounding area through mounted sensors on the robot [5]. Obstacle avoidance technology in robotics is used for avoiding a collision.

III. CIRCUIT DESIGN AND HARDWARE

A. Microcontroller

The Arduino Uno is type of a microcontroller which is useful for controlling robotic activities. It is a microcontroller board primarily based completely on the ATmega328 as shown in Fig.1. It has 14 digital input and output pins, 6 analog inputs, out of 14 pins 6 can be used as PWM pins.



Fig.1. Arduino Uno

The Arduino Uno board provides a manipulate mechanism to the various sensors which are connected to the board. The software programs for robotic operations are written in Arduino Integrated Development Environment (IDE). Arduino IDE is an open-supply program software that makes it clean to write down code and add it to the board. The pin configuration is described in Table I with pin description.

Pin No	Name	Type	Description
1-2, 5-16	D0-D13	I/O	Digital Input Output port
3,28	Reset	INPUT	Reset(Active Low)
4,29	Ground	PWR	Supply Ground
1 7	3V3	OUTPUT	+3.3V Output(from FTDI)
1 8	AREF	INPUT	ADC reference
19-26	A7-A0	INPUT	Analog input channel 0 to 7
2 7	+5V	OUTPUT or INPUT	+5V output (from on- board regulator) or +5V(from external power supply)
3 0	VIN	PWR	Supply Voltage

Table I: Pin Configuration of Arduino Uno

B. Bluetooth

The Bluetooth module used is the HC-05 Bluetooth Serial Module. It is shown in fig.2. It is a short-range wireless networking technology. It is useful to pair two devices, such as smartphones and headsets, cameras and printers, and keyboards and computers. It is sometimes called cable- replacement technology. This is required for setting up the wireless connection between the microcontroller and the mobile application.

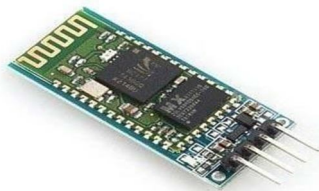

Fig.2. Bluetooth module

C. Obstacle Detection

The important task of the seed sowing robot is Obstacle Detection. Fig. 3 illustrates the ultrasonic sensor working with the help of waveforms. The first waveform is Trigger, the second is 5 consecutive clock pulses and the third is time it takes to leave and return. Ultrasonic sensor is used for the obstacle detection. If the obstacle is detected the robot stop. If the signal gets returned through a high-level time duration; test distance can be calculated as shown in equation (1).

$$\text{Test Distance} = \text{Velocity of Sound} \times \text{High Level Time} / 2 \quad (1)$$

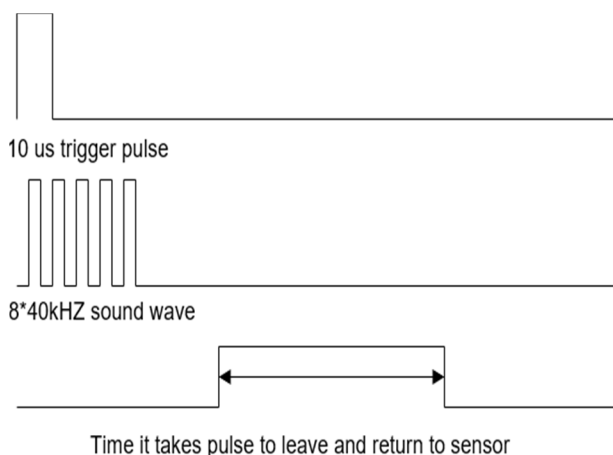

Fig. 3. Waveforms of Ultrasonic Sensor

D. DC Motor

DC motor is tool electromechanical that converts electric electricity into mechanical energy. The conduct of motor for diverse enter situations is given in Table II.

Pattern	Input A	Input B
Stop	LOW	LOW
Anticlockwise	LOW	HIGH
Clockwise	HIGH	LOW
Stop	HIGH	HIGH

Table II: Pattern for DC Motor

E. Seed Sowing Mechanism

For the seed sowing process, servomotor requirement is necessary. This is not anything however an easy electric motor, operating with the assist of servomechanism. Fig. 4 indicates seed sowing mechanism. Servo motor is a rotary actuator or linear actuator. It allows for precise control of angular and velocity, linear position, and acceleration as the shaft of motor can be rotation turned by the required degree which is attached to the hopper containing seeds, the mechanism of seed sowing is achieved easily. It consists of suitable motor or sensor can be used for position feedback.

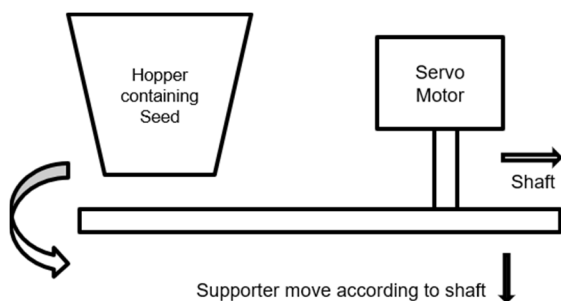

Fig. 4. Seed Sowing Mechanism

F. Motor Driver

The motor driver used is L298N motor driver. The L298N motor controller is based upon the H- bridge configuration, which is useful for controlling the direction of rotation of a DC motor. It has a high operating voltage. The motor drivers are used for running the motors.

G. Servo Motor

A servo motor is a basic unit of a servo system and is used with a servo drive. The Servomotor includes the motor that drives the load and consist of the position detection component, such as an encoder. The servo system varies the controlled amount, such as position, speed, or torque, according to the set target value for precisely control of the machine operation.

H. DHT 11 Sensor

DHT 11 sensor is used for sensing temperature and humidity value. It can also be useful for local whether station, automatic climate change and environment monitoring.

IV. WORKING PRINCIPLE

The robot performs seed sowing which is operated by a rechargeable battery. Seed Sowing Robot consists of Arduino Mega AT 328P microcontroller, Bluetooth, battery, ultrasonic sensor, motor driver, servo motor with its driver. The robot will sow the fixed quantity of seeds to the entire row. Before sowing the seed on the field, it digs the soil with a certain depth. The servo motor is used to enables the opening and closing of the hopper bottom through that opening the seeds are falls onto the field.

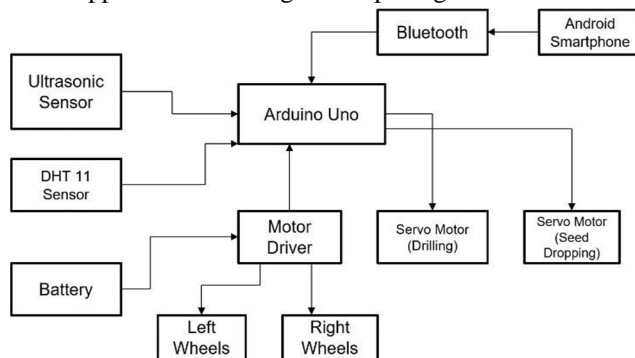

Fig. 5. Block Diagram of Seed Sowing Robot

After the seeds have been sown, covering up the soil is done using a bent rod. It has a programmed control toward all paths, seed sowing, and covering the soil. It simplifies the operation of seed sowing and also increases the yield of the crop.

To select a seed based on Fuzzy Logic

- 1) *Step 1:* Checking for the temperature and humidity value using sensors.
- 2) *Step 2:* The crisp inputs of temperature and humidity value are considered and the membership functions are assigned for each input value considering the triangular type of membership functions.
- 3) *Step 3:* Rules are assigned considering centroid method of defuzzification.
- 4) *Step 4:* By using these rules we can predict the crop. The flow of the seed selection process is described in Fig. 6.

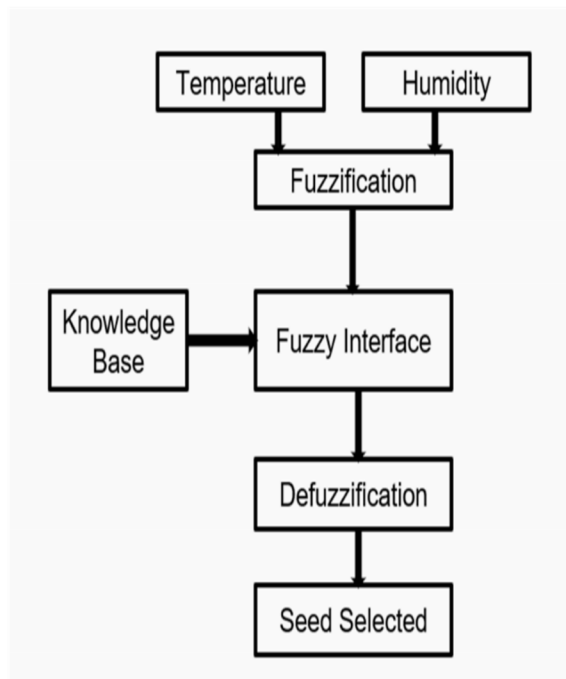

Fig. 6. Seed Selector Block Diagram

V. RESULT

The Seed Sowing Robot gives a compact, low-cost system with an efficient output. Fig. 7 depicts the top view of the Seed Sowing Robot. The Robot is used for obstacle detection, Seed sowing mechanism.



Fig. 7. Top View of Seed Sowing Robot

The temperature and humidity values of the soil are taken as input and the membership functions are assigned for each input value. Considering the centroid method of defuzzification rules are assigned. Using these rules, the seed is predicted as shown in Fig. 8.

```

COM8
TMoisture : 1019
tomato
TEMPRATURE = 29.79*C
TEMPRATURE = 32.23*C
Soil Moisture : 1020
tomato
TEMPRATURE = 27.34*C
Soil Moisture : 1021
tomato
TEMPRATURE = 26.86*C
Soil Moisture : 1021
tomato
    
```

Fig. 8. Seed Prediction using DHT 11 Sensor

The movement of the robot is controlled using the buttons as mentioned in Fig. 9.

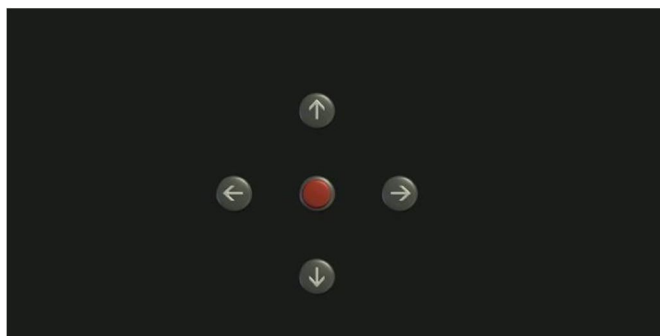

Fig. 9. Buttons for Controlling Robotic Movements

VI. CONCLUSION

The Seed Sowing Robot has the potential to increase productivity. This automatic way of sowing seeds employing a robot reduces the labor requirement. This technique has been developed for the sowing of seeds in an automatic way. The robot is useful for farmers for doing the farming process. This robot is very useful for farmers who are intended to do the agricultural activity but facing the problem of labor. As compared to the manual and tractor-based seed sowing, the energy required for this robot is in a smaller amount. So, this technique is going to be a far better option for the farmers who want to perform the seed sowing operation in a well-organized manner.

REFERENCES

- [1] Abdulrahman, Mangesh Koli, Umesh Kori, Ahmadakbar, "Seed Sowing Robot", International Journal of Computer Science Trends and Technology (IJCTST) – Vol. 5 Issue 2, Mar– Apr 2017.
- [2] Swati D. Sambare and S. S. Belsare, "Seed Sowing Using Robotics Technology", International Journal of scientific research and management (IJSRM), vol. 3, no. 5, pp. 2889- 2892, 2015.
- [3] Jayakrishna P V S, Suryavamsi Reddy M and Jaswanth Sai N. "Autonomous Seed Sowing Agricultural Robot", International Conference on Advances computing, 2018.
- [4] Vidya Yedave, Punam Bhosale, Jyoti Shinde³, Prof. Jagdish Hallur, "Automatic Seed Sowing Robot", International Research Journal of Engineering and Technology (IRJET), 2019.
- [5] M.Aravind kumar, Akkarapalli Sanjeev Reddy k.sagadevan, "Automatic Seed Sowing and Irrigation Agribot Using Arduino", International Journal of Pure and Applied Mathematics Vol. 119, No. 14, ISSN: 1314-3395, 2018.
- [6] Dhiraj Arun Patil; Manish upadhye; F. S. Kazi; N.M. Singh, "Multi Robot Communication and Target Tracking System with Controller Design and Implimentation of SWARM Robot using Arduino," 2015 international conference on Industrial Instrumentation and Control, pp 412-416.
- [7] Amrita Sneha. A, Abirami. E, Ankita. A, R. Praveena and R. Srimeena, "Agricultural Robot for automatic ploughing and seeding," 2015 IEEE Technological Innovation in ICT for Agriculture and Rural Development (TIAR), Chennai, 2015, pp. 17-23.
- [8] Dr. Vijayashree R Budyal (May 09, 2019) Fuzzy Logic Based Automated Seed Sowing Robot Presented By: Anusha K, Achuth Kumar V, Prajwal Kumar J, Sahana Br - <https://anushakgowda.blogspot.com/2019/05/blog-post.html>
- [9] <https://www.geeksforgeeks.org/fuzzy-logic-introduction/>
- [10] <https://components101.com/>



10.22214/IJRASET



45.98



IMPACT FACTOR:
7.129



IMPACT FACTOR:
7.429



INTERNATIONAL JOURNAL FOR RESEARCH

IN APPLIED SCIENCE & ENGINEERING TECHNOLOGY

Call : 08813907089  (24*7 Support on Whatsapp)