



IJRASET

International Journal For Research in
Applied Science and Engineering Technology



INTERNATIONAL JOURNAL FOR RESEARCH

IN APPLIED SCIENCE & ENGINEERING TECHNOLOGY

Volume: 9 Issue: X Month of publication: October 2021

DOI: <https://doi.org/10.22214/ijraset.2021.38243>

www.ijraset.com

Call:  08813907089

E-mail ID: ijraset@gmail.com

Effect of Hybrid Controller on a Heat Exchanger for ENHANCING HEAT Transfer Rate of Al_2O_3 Nanofluid

R. Vivekananthan

Department of Mechanical Engineering, Government College of Engineering, India

Abstract: In this research paper, a hybrid controller is designed and developed which maintains the outlet temperature of a shell and tube heat exchanger by varying the cold water flow rate in such a way that conform the desired set value. Al_2O_3 nanofluid is mixed with water is to be used as the cooling fluid to increase the rate of heat transfer. PID controller only is not suitable for precise and a wide range of temperature control requirement. So that hybrid controller is designed and implemented by combining methods of fuzzy logic and PID controller's concepts using Labview. Experiments were done on parallel flow shell and tube heat exchanger in a closed cycle system. The performance of the heat exchanger system is improved by a hybrid controller and the heat transfer rate is enhanced by aluminum oxide nanofluid.

Keywords: Heat transfer, shell and tube heat exchanger, Al_2O_3 nanofluid, Labview, hybrid controller Introduction

I. INTRODUCTION

The industry is needed a real time system for monitoring and controlling of temperature in a simpler manner with easy identification and rectification of errors. Heat exchanger is one among the element in the industry application. The temperature of hot fluid must be maintained at constant temperature as process variable and is subjected to control variable either varying flow rates of hot fluid or cold fluid or both during its operation. Since conventional cooling process of liquid is time consuming process, an intelligent system is needed to speed up the cooling process.

In recent years, large numbers of attempts have been made to make the heat exchanger to be compact and several techniques have been proposed to achieve a desired heat transfer rate in the existing heat exchangers. Nowadays dynamic behaviour of heat exchanger is a topic of active research interest with intelligent controller. The operating parameters of hot and cold fluids inlet and outlet temperatures, flow rates and flow velocities are subjected to various conditions for the process of getting steady state conditions. Studying of dynamic performance of heat exchangers is also required under diverse situations of operation and control.

The dynamic characteristics of the shell and tube heat exchanger controlling temperature is a nonlinear response and also time varying and low speed of response system. The process requirements are minimising settling time or rise time with no overshoot. For these characteristics, intelligent control algorithms and its control strategies would provide significant improvements compared to conventional PID control strategy. Since the controlling of temperature process with conventional PID controller cannot meet a precise and a wide range of temperature control requirement, the temperature control system would be designed with combining fuzzy and PID control methods. For the past few years the heat transfer rates are increased and enhanced using nano fluid. Conventional heat transfer fluids like water, cooling oil, ethylene glycol etc have inherently low thermal conductivity relative to metals and its oxides. Cooling fluids with suspended solid particles will give better heat transfer properties compared to conventional heat transfer fluids.

Nanometer size particles are mixed and suspended in a common heat transfer fluids for producing nanofluids. These nanofluids have higher thermal conductivity than its base fluids (Daniel J Correa and Jacinto L Marchetti, 2017; Lazarus Godson et al, 2010). Many fluids have thermal conductivities well below thermal conductivities of metals. Saman Rashidi et al (2018) have done experiment on nano fluids Al_2O_3 , TiO_2 , and SiO_2 and found Al_2O_3 , have higher the effective thermal conductivity (Bashirnezhad K, Rashidi M M, Yang Z, Bazri S, Yan W M, 2015). From these nano fluids Al_2O_3 nanofluid has the highest values of thermal conductivity followed by TiO_2 and SiO_2 . Lee S et al (1999) have done on experiments and obtained the thermal conductivity of nano fluids and also studied the mechanisms of nano fluids on its thermal conductivity enhancement. Concentration of nano fluid influences the thermal conductivity. Adnan M. Hussein et al (2013) noted concentration increases, the surface area of particle also increases and exchange more heat by varying concentrations from 1 to 6%.

Khaled et al (2005) conducted experiments and found the dispersive elements enhance heat transfer compared with a uniform distribution of the dispersive elements (Dawit Bogale, 2014; Jaafar Albadr et al, 2013) conducted experiments and analysed Al_2O_3 nano fluid heat transfer and reported their results when increasing heat transfer coefficient with increasing Reynolds number in a laminar flow region maintaining constant wall heat flux. But forced convection is mostly used for enhancing thermal conductivity of nanofluids heat transfer rate. Sadik Kakac et al (2009) have done investigations on forced convection heat transfer by varying flow rate at different heat transfer conditions. They noticed that the heat transfer enhancement is much more in forced convection.

Moshizi SA and Malvandi A (2016) prepared a nanofluid with suspension of nanophase powders for enhancing heat transfer (M Raja et al, 2013). Yimin Xuan and Qiang Li (2000) described heat transfer performance of the nano fluids with suspension of nano powders and illustrated the stability and evenness of suspension nano particles by TEM images. Koblinski et al (2002) conducted experiments and measured the viscosity of Al_2O_3 and water nano fluids against shear rate. Their results showed that the increase of viscosity with increase in particle concentrations. Minsuk Kong and Seungro Lee (2020) have found the overall heat transfer rate. The overall heat transfer rate is directly proportional to inlet fluid temperature and indirectly proportional to viscosity of Al_2O_3 nanofluids with three different volumetric concentrations (0.38%, 0.81% and 1.30%).

Nano fluids are considered by its important advantages and applied convection heat transfer fluid to increases heat transfer rate. Nor Azwadi Che Sidik et al (2015) used nanofluids in engine cooling system. The nanoparticles were dispersed in the engine oil to enhance the thermal conductivity of the liquid and also to improve the performance of lubricants and reduce friction. Hsien-Hung Ting and Shuhn-Shyurng Hou (2015) proved that the increasing convective heat transfer is increased by the increasing surface area of heat exchanger in a square cross-section duct. For increasing convective heat transfer, the particle volume concentration in a heat exchanger is varied in different ways (Cong Qi et al, 2017; Sun B et al, 2016). Cong Qi found that heat transfer is increased more in turbulent flow by slight increase in frictional resistance coefficients than laminar flow of TiO_2 nanofluids.

The problem of heat transfer deterioration for drag reducing fluids was solved by K factor. Debi Prasad Dash et al (2013) investigated the performance of conventional controllers and fuzzy logic controller using labview software to the heat exchanger system. From the comparison of results fuzzy logic controller gives optimum results compared to other controller.

When compared with other materials like water or oil, nano fluid has the high rate of heat transfer. These nano materials are having thermal, electrical and magnetic properties which make this material efficiently. Now different type of nano fluids are used as alternative coolants for many areas such as electronics, automotive, air conditioning, aircraft and nuclear applications and dairy and food industry. From the literature, the researchers suggest that nanofluids have great potential for enhancing of heat transfer in a heat exchanger. Hybrid controllers can also be used to improve the performance of control unit to control the temperature of outlet of hot fluid in the shell and tube heat exchanger system with Al_2O_3 nano fluid.

II. EXPERIMENTAL SETUP

This system will maintain the hot water outlet temperature at a desired set point. Fig.1 shows a parallel flow shell and tube heat exchanger experimental setup. An electric heater is placed directly into the hot water tank and maintained the heat. The heater is switched on and temperature is set to 75°C . It was waited until the constant temperature is reached. The cooling liquid tank is placed separately and cooling liquid is forced over shell and tube heat exchanger. The amount of heat transfer from the hot fluid is directly proportional to the rate of cooling liquid flow over it.



Fig.1 Experimental setup

The experimental setup consists of centrifugal pumps and tanks. The cooling liquid is pumped by a separate pump from a built in tank and passed through pipe and return to tank through control valve by a closed system. The pump is switched on and hot water is allowed into pipe and circulated. The cold fluid that is Al_2O_3 nano fluid is pumped into the heat exchanger for removing the heat and then it flows through the shell to tank for rejection of heat. The cold fluid is pumped through globe flow control valve which is opened according to control signal. The proper control signal is determined by the controller for the flow rate of cooling liquid. The corrected signal sent to globe flow control valve and opened for varying the flow rate.

The temperature sensors sensed the actual temperature and compared it to the set temperature. If error occurs the controller produce a control action that will keep the hot water outlet temperature at or near the desired temperature. The control valve gets the calculated air pressure as input from current to pressure converter. This in turn accepts the pressure input from air regulator and this calculated air is used to regulate the cooling liquid. The regulated pressure output is proportional to the input current. The voltage to current converter converts the voltage (0-5 V) to the proportional current in the range of (4-20 mA).

III. LABVIEW SOFTWARE

Fig.2 is a graphical representation of software program to acquire the sensor signal and process it. The controller determined control signal by the control algorithm based on the program. Labview software consists of icons that represent typical programming elements such as loops, variables, PID and fuzzy logic controller. The controller sends the appropriate output to the control valve for making correction.

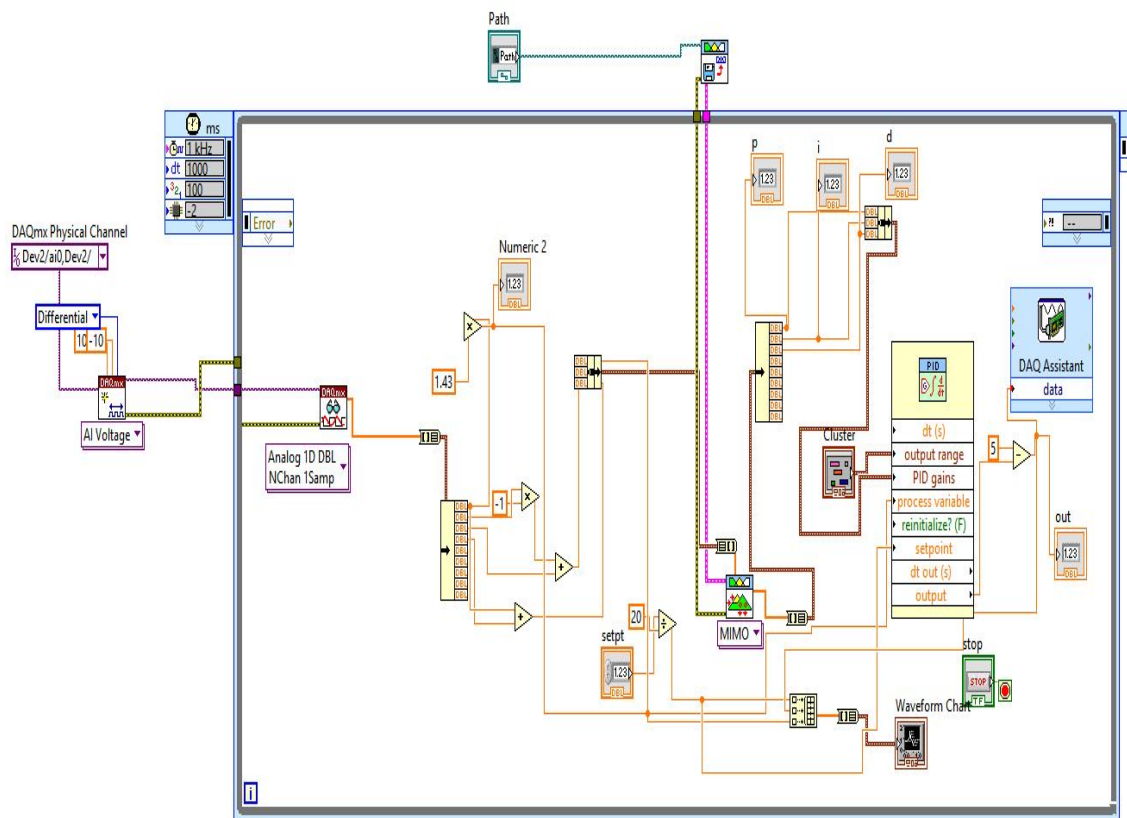

Fig.2 Graphical representation of software program

The fuzzy controller has been designed and programmed in a separate while loop for getting desired parameters. This fuzzy controller is designed with three input variables and one output variable. The input variables were hot fluid outlet temperature, temperature difference of hot fluids, temperature difference of cold fluids and the output variable is flow rate of cold Al_2O_3 nano fluid in the shell side. Triangular and trapezoid shaped membership functions were used for the input and output variables. The linguistic variable values of hot fluid outlet temperature, temperature difference of hot fluids, temperature difference of cold fluids (low (L), medium (M), high (H)) are the three fuzzy values.

Table 1 Values of linguistic variable

$\Delta T_{\text{(hot fluid)}}$	$\Delta T_{\text{(cold fluid)}}$	T (hot fluid outlet)		
		L	M	H
L	L	L	L	H
	M	L	M	H
	H	M	M	H
M	L	L	M	H
	M	M	L	M
	H	M	M	M
H	L	L	M	H
	M	L	H	M
	H	M	M	M

The linguistic values for the output variables are low (L), medium (M), high (H) as shown in Table 1. For fuzzy logic control system, the whole set of fuzzy rules are framed for negative feedback in the control loop and also max-min interference system has been used.

IV. RESULTS AND DISCUSSION

In this paper, the heat transfer characteristics of Al_2O_3 nano fluid of parallel flow shell and tube heat exchanger is presented. Some of the observations were made on heat transfer characteristics with varying composition of water and nano fluid system [7]. The composition was taken based on volume. The temperature is set to $65^{\circ}C$. First Labview program is written for only PID controller and heat transfer characteristics are analysed. In the graph, block line indicates the set temperature, red line indicates the actual temperature measured and the blue line indicates the valve opening as per the command signal from the controllers. Fig.3 to Fig.6 show experimental results of nanofluid concentrations and plotted the response time of heat transfer rates for various concentration of nanofluid and different controllers.

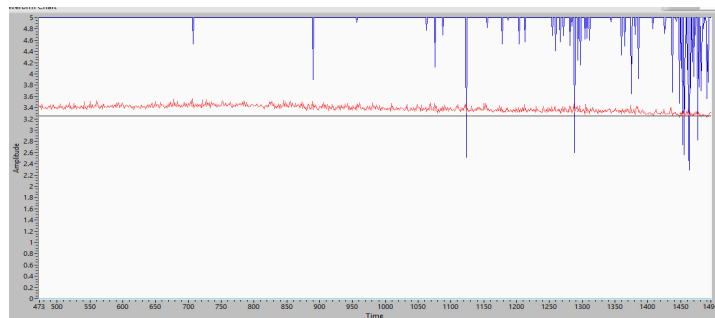

Fig.3 PID controller with 1% concentration of nanofluid

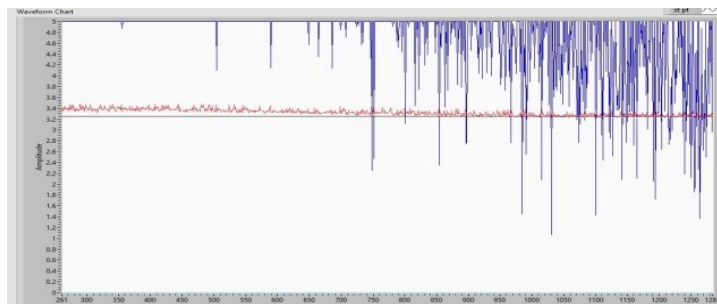

Fig.4 PID controller with 5% concentration of nanofluid

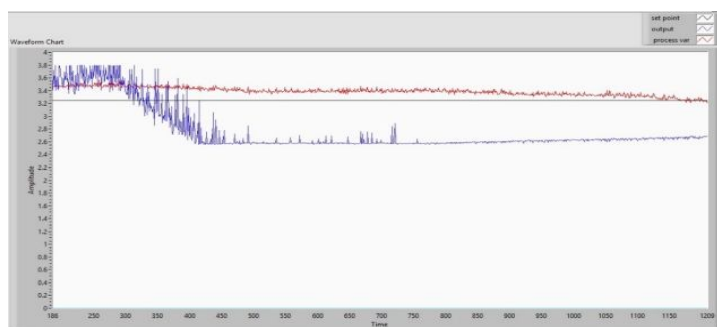

Fig.5 Fuzzy logic controller with 5% concentration of nanofluid

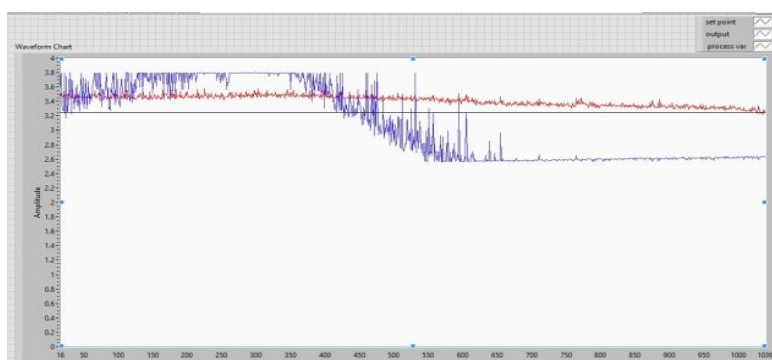

Fig.6 Hybrid controller with 5% concentration of nanofluid

PID controller output increases instantly and the control valve is opened for some instance for increasing the flow rate. The actual temperature is measured and is traced for the set point by closed loop control system. As shown in Fig.3 error is too high, the output flow rate gets significantly smoother but as the error is low flow rate is oscillated. From experimental investigation, the nanofluid concentrations is varied from 1% to 5% and it is found that increase in nanofluid concentration increases the heat transfer rate when comparing the Fig.3 and Fig.4. The Fig.3 shows the effect of mass flow rate of cold fluid and also indicates that the increase in temperature difference will give maximum flow rate of cold fluid results in increase in the heat transfer rate. The gain coefficients are $K_p=4.1$, $K_i=0.003$ and $K_d=0.052$. This experiment is again set for fuzzy logic controller. Comparing the results of PID and fuzzy logic controllers, PID gives quick response with high oscillation as shown in Fig.4.

It is observed that the settling time of the PID controller is lesser than fuzzy controller. And also the fuzzy logic controller reduced 80% of the overshoot and 15% response improvement as compared to the PID controller. From the experimental results, the graphs Fig.3, Fig.4 and Fig.5 show that fuzzy controller has better dynamic characteristics in its response and reduced steady state error. The combining effect of fuzzy controller and PID controller controls the outlet temperature of the hot fluid to its desired set value in the shortest possible time irrespective of process disturbances as shown in Fig.6. This hybrid controller is also used to reduce the overshoot 20% and optimize the control performance. The effect of hybrid controller that is combination of fuzzy and PID controllers gives a much better result than the PID controller.

High oscillatory response by PID and large settling time by fuzzy logic controller are occurred. This problem is identified and approached to hybrid controller to minimize these errors. As shown in Fig.4, Fig.5 and Fig.6, the hybrid controller shows the better control performance than PID controller and fuzzy logic controller individually. By implementing hybrid controller, the overshoot was reduced to 20% and stabilizing the temperature in a short time, even with good performance. From the results, the hybrid controller gave less overshoot, quicker response and minimum steady state error thereby hybrid controller is making stronger than individual PID and fuzzy controller.

This hybrid controller is implemented to the system with Al_2O_3 nano fluid as cooling medium has a good dynamic character. From observations, it is found that 5% nanofluid concentrations increase the heat transfer rate when comparing the Fig.3 and Fig.4 but more fluctuations in response.

Hybrid controlling effect satisfied the precise temperature control and met wide range of the temperature control requirements of the shell and tube heat exchanger. Fig.6 shows the result of hybrid controller with Al_2O_3 nano-fluid. From the experimental investigation, hybrid controller with nano-fluid takes less time to maintain the outlet temperature of the hot fluid. Fluctuation in output line is very low and varying proportionally for better controlling. From this we conclude that hybrid controller with nano-fluid gives better performance of controlling temperature in heat exchanger system.

V. CONCLUSION

In this paper, the effect of volumetric concentration of Aluminum oxide nano particles on the heat transfer and controlling factor affecting the heat transfer rate were investigated. PID, Fuzzy logic and hybrid controllers are designed and implemented for maintaining the output temperature of shell and tube heat exchanger using Labview software and compared the characteristics. This system provides a very good tool for learning how to implement hybrid controller. Aluminum oxide nano-fluid used as the cooling medium for heat transfer enhancement. From the experimental investigation, we conclude that aluminum oxide nano-fluid gives better heat transfer results with 5% volumetric concentration.

REFERENCES

- [1] Daniel J Correa and Jacinto L Marchetti, "Dynamic Simulation of Shell-and-Tube Heat Exchangers", Heat Transfer Engineering, **2017**, Vol.8, No.1, pp.50-59
- [2] Lazarus Godson, Raja B, Mohan Lal D and Wongwises S, "Enhancement of heat transfer using nanofluids -An overview", Renewable and sustainable energy reviews, **2010**, Vol.14, No.2, pp.629-641
- [3] Saman Rashidi, Omid Mahian and Ehsan Mohseni Languri, "Applications of nanofluids in condensing and evaporating systems-A review", Journal of Thermal Analysis and Calorimetry, **2018**, Vol.131, No.3, pp.2027-2039
- [4] Bashirnezhad K, Rashidi M M, Yang Z, Bazri S, Yan WM, "A comprehensive review of last experimental studies on thermal conductivity of nanofluids". Journal of Thermal Analysis and Calorimetry, **2015**, Vol.122, pp. 863-84
- [5] Lee S., Choi S.U.S., Li S. and Eastman L A, "Measuring thermal conductivity of fluids containing oxide nano particles", Journal of Heat Transfer, **1999**, Vol.121, pp.280-289
- [6] Adnan M. Hussein, Sharma K V, Bakar R A and Kadirgama K, "The Effect of Nanofluid Volume Concentration on Heat Transfer and Friction Factor inside a Horizontal Tube", Nanomaterials, **2013**, Vol.2013, pp.1- 12
- [7] Khaled A.R.A and Vafai K, "Heat transfer enhancement through control of thermal dispersion effects", International Journal of Heat and Mass Transfer, **2005**, Vol.48, pp.2172-2185
- [8] Dawit Bogale, "Design and Development of Shell and Tube Heat Exchanger for Hararrewery Company Pasteurizer Application", American Journal of Engineering Research, **2014**, Vol.3, No.10, pp.99-109
- [9] Jaafar Albadr, Satinder Tayal and Mushtaq Alasadi, "Heat transfer through heat exchanger using Al_2O_3 nanofluid at different concentrations". Case Studies in Thermal Engineering, **2013**, Vol.1, No.1, pp.38-44
- [10] Sadik Kakac and Anchasa Pramuanjaroenkij, "Review of convective heat transfer enhancement with nanofluids", International Journal of Heat and Mass Transfer, **2009**, Vol.52, pp.3187-3196
- [11] Moshizi S A and Malvandi A, "Different modes of nanoparticle migration at mixed convection of Al_2O_3 -water nanofluid inside a vertical microannulus in the presence of heat generation/absorption", Journal of Thermal Analysis and Calorimetry, **2016**, Vol.126, pp.1947-1962.
- [12] Raja M, Vijayan R, Suresh S and Vivekananthan R, "Effect of heat transfer enhancement and NOx emission using Al_2O_3 /water nanofluid as coolant in CI engine", Indian Journal of Engineering and Materials Sciences, **2013**, Vol.20, No.5, pp.443-449
- [13] Yimin Xuan and Qiang Li, "Heat transfer enhancement of nanofluids", International Journal of Heat and Fluid Flow, **2000**, Vol.21, No.1, pp.58-64
- [14] Koblinski P., Philipot S.R., Choi S.U.S. and Eastman L A, "Mechanism of heat flow in suspension of nano-sized particle (nanofluids)", International Journal of Heat and Mass Transfer, **2002**, Vol.45, pp.855-863
- [15] Minsuk Kong and Seungro Lee, "Performance evaluation of Al_2O_3 nanofluid as an enhanced heat transfer fluid", Advances in Mechanical Engineering, **2020**, Vol.12, No.8, pp.1-13
- [16] Nor Azwadi Che Sidik, Muhammad Noor Afiq Witri Mohd Yazid and Rizalman Mamat, "A review on the application of nanofluids in vehicle engine cooling system", International Communications in Heat and Mass Transfer, **2015**, Vol.68, pp.85-90
- [17] Hsien-Hung Ting and Shuhn-Shyurng Hou, "Investigation of Laminar Convective Heat Transfer for Al_2O_3 -Water Nanofluids flowing through a square cross-section duct with a constant heat flux", **2015**, Materials, Vol.8, pp.5321-5335
- [18] Cong Qi, Chunyang Li and Guiqing Wang, "Experimental Study on the Flow and Heat Transfer Characteristics of TiO_2 -Water Nanofluids in a Spirally Fluted Tube", Nanoscale Research Letters, **2017**, Vol.12 No.516, pp.1-12
- [19] Sun B, Zhang Z and Yang D, "Improved heat transfer and flow resistance achieved with drag reducing Cu nanofluids in the horizontal tube and built-in twisted belt tubes", International Journal of Heat and Mass Transfer, **2016**, Vol.95, pp.69-82
- [20] Debi Prasad Dash and Amruta S.Deshpande, "Design and Simulation of Fuzzy Controller for Heat Exchanger", International journal of systems, algorithms and applications, **2013**, Vol.3, pp.83-86



10.22214/IJRASET



45.98



IMPACT FACTOR:
7.129



IMPACT FACTOR:
7.429



INTERNATIONAL JOURNAL FOR RESEARCH

IN APPLIED SCIENCE & ENGINEERING TECHNOLOGY

Call : 08813907089  (24*7 Support on Whatsapp)