



IJRASET

International Journal For Research in
Applied Science and Engineering Technology



INTERNATIONAL JOURNAL FOR RESEARCH

IN APPLIED SCIENCE & ENGINEERING TECHNOLOGY

Volume: 4 Issue: VI Month of publication: June 2016

DOI:

www.ijraset.com

Call:  08813907089

E-mail ID: ijraset@gmail.com

Analysis of Different Controllers for Controlling Buck Converter

Lalit Kumar Sahu^{#1}, Dushyant Singh^{*2}

¹PG Scholar, ²Assistant Professor, Department of Electrical Engineering, CSVTU, Bhilai, India.

Abstract— In this paper a Hybrid Controller is introduced i.e. PID-NN Controller (PID with neural network) for improving the output response of buck converter. Hybridization is somewhat, combining the advantageous part of both controllers together. Here, Buck converter's Output voltage is controlled by different controllers and comparing results obtained from Controllers. Classical linear techniques have stability around the operating point. This Paper shows comparison of different controller's response in order to control buck converter. The output response of Buck Converter is tested with different controllers individually & results are shown. Neural network technique used as gain scheduler that computes the values of Proportion (Kp), Derivative (Kd), & integral constant (Ki) values for PID Controller. PID output provides the change in duty ratio and then it applied to PWM block to produce the required duty cycle for Switch of Buck Converter. The objective is to improve the System's output response under different load variations and also to use advantage of neural network such as strong learning ability and adaptability. All simulation are done at MATLAB/SIMULINK.

Keywords— Buck Converter, PID-Neural network based Hybrid Controller, Fuzzy Logic Controller, PID Controller, MATLAB.

I. INTRODUCTION

This Buck converter is a DC-DC converter whose objective is to provide low output voltage level from high voltage level. In industries, various types of loads which may have non-linear effects received at the output thus there is a chance of receiving undesired voltage at load, which may reduce the efficiency of converter. Conventional control techniques used for dc-dc Converters are PID controllers which tend to provide linear characteristics [1].

There are both linear as well as non-linear control methods are available. Conventional PID controllers are based on precise mathematical models that have assured stability, reliability, and controllability, despite their effectiveness for linear systems, conventional PID controllers are not suitable for nonlinear systems and higher-order and time delayed systems [2].

For controlling buck converter, fuzzy based system is a non-linear control method. In fuzzy, if the designer has the complete idea of whole process, he can easily design the control system, but the problem with fuzzy controllers is that they are applied to system based on the experience of designer, not on any theoretical methods, that affects stability and controllability issues of these fuzzy controllers. Fuzzy logic, which is the logic on which fuzzy control is based, is much closer in spirit to human thinking and natural language than the traditional logical systems. Basically, it provides an effective means of capturing the approximate, inexact nature of the real world [3].

Hybrid system is somewhat, combining the advantageous quality of different control techniques & that makes it more powerful. A conventional PID controller for regulating Buck converter with a neural network based system is proposed which calculates the values of different parameters of PID controller & in this way controlling action takes place.

The implemented ANN controller is trained offline using the data obtained from the experiments performed by the system. Artificial neural network is a model consist of artificial neurons which process the information from input and provides controlled output. Here, ANN is used for computing the gains values of PID controller so that change in duty cycle is produced.

II. SUBSYSTEMS

This block provides the output voltage and inductor current waveform at output. Inputs to this block are duty cycle, input voltage, and load current as shown in figure 1.

The inductor's current can be computed from the first loop when differential equation is solved by applying KVL to the basic circuit of buck converter:

$$V_{in}D = L \frac{di_L}{dt} + i_L R_L + V_O \dots\dots\dots(1)$$

$$L \frac{di_L}{dt} = V_{in}D - i_L R_L - V_O \dots\dots\dots(2)$$

International Journal for Research in Applied Science & Engineering Technology (IJRASET)

$$i_L = \frac{1}{L} \int V_{in} D - i_L R_L - V_o \dots \dots \dots (3)$$

Where,

V_{in} = Input Voltage, i_L = Inductor's Current, R_L = Effective Series Resistance of Inductor,
 V_o = Output Voltage, L = Inductor.

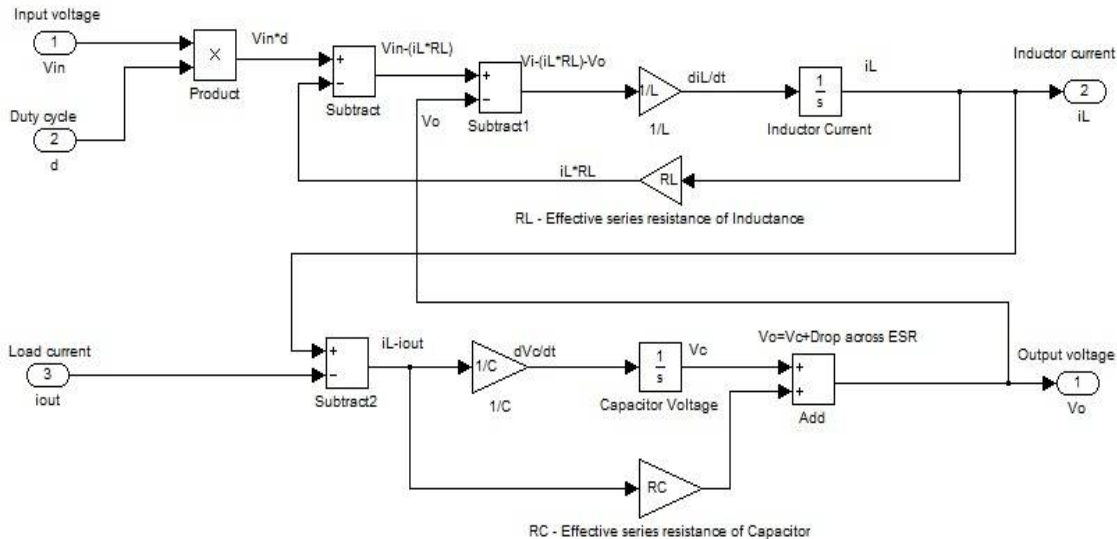

Fig.1 Subsystem for Buck Converter

The output voltage can be computed from second loop which is the addition of the voltage at capacitor and voltage drop across the Capacitor's Effective Series Resistance (Rc). From KCL at the capacitor node we get:

$$C \frac{dV_c}{dt} = i_L - i_{out} \dots \dots \dots (4)$$

$$V_c = \frac{1}{C} \int (i_L - i_{out}) dt \dots \dots \dots (5)$$

$$V_o = V_c + \text{Drop across ESR of Capacitor} \dots \dots \dots (6)$$

$$V_o = V_c + R_c (i_L - i_{out}) \dots \dots \dots (6)$$

Where,

i_{out} = Current at load, C = Capacitor (Farad),
 V_c = Capacitor voltage, R_c = Capacitor's Effective Series Resistance.

As name suggests that this block has an objective of providing series of PWM (pulse-width modulated) pulses based on varying duty cycle. As explained above, that buck converter has two modes of operation i.e.

- When converter's switch is on (T_{on}) &
- When converter's switch is off (T_{off}).

The block consist of two inputs are:

- From the controller, change in duty cycle.
- Switching Frequency F_s , as shown in figure 2

International Journal for Research in Applied Science & Engineering Technology (IJRASET)

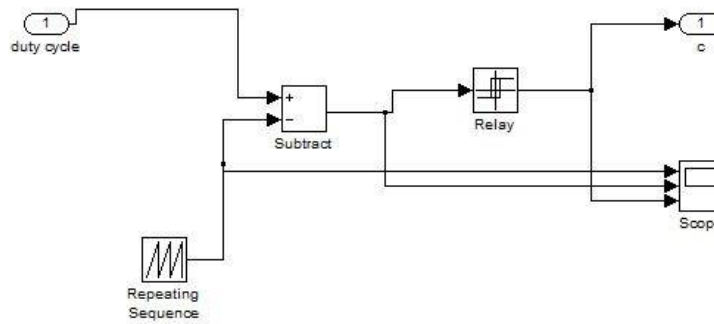

Fig.2 Subsystem for PWM Waveform Generator

III.METHODOLOGIES

A. PID Controller

In Simulink the default PID controller available is used to generate change in duty cycle, according to the error signal provided by comparator. The PID's parameter can be provided either manually or by auto tuning concept provided by mat lab. Due to PWM logic, linearization error occurs because the forward path linearizes to zero. PID Controllers are most commonly used controllers in process industries, about 90% of industrial loops use PID controller. This is because of its simple structure, easy implementation, robust nature and less number of tuning parameters.

For using the auto tuning feature of PID controller, one needs to model Buck Converter as a transfer function, we get:

$$V_{in} D = L i_L S + i_L R_L + V_o \dots \dots \dots (7)$$

On neglecting the drop across R_c ,

$$i_L = \frac{V_o}{R} + C V_o s \dots \dots \dots (8)$$

From above equation, substituting values, thus we get Buck converter's open loop transfer function model.

$$\frac{V_o}{D} = \frac{\frac{V_{in}}{L C}}{s^2 + s\left(\frac{1}{R_o C} + \frac{R_L}{L}\right) + \left(\frac{1}{L C} + \frac{R_L}{R_o L C}\right)} \dots \dots \dots (9)$$

Where,

V_o = Output Voltage, V_{in} = Input Voltage, R_o = Resistance at load (Ω),
 L = Inductor (H), C = Capacitor (F), R_L = Effective Series Resistance of Inductor (Ω). The buck converter in a transfer function model as shown in figure 3.

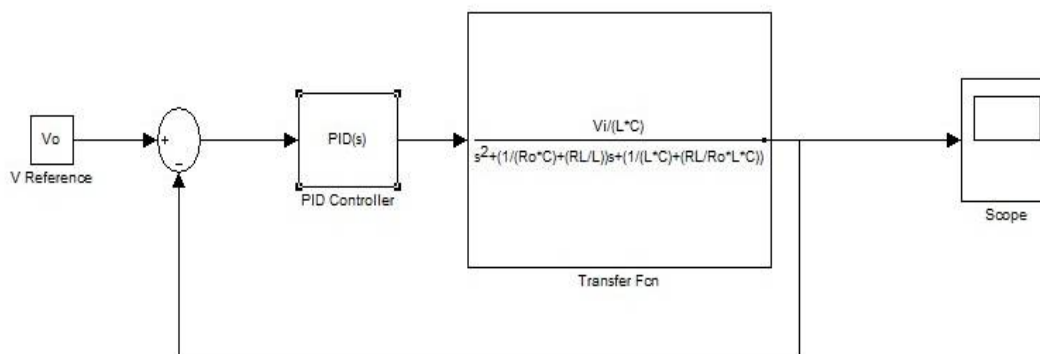

Fig.3 Transfer function model with PID Controller

International Journal for Research in Applied Science & Engineering Technology (IJRASET)

B. Ordinary Fuzzy Logic Controller

The controlling process can be achieved through fuzzy controller by using a sets of Linguistic rules. It does not require any mathematical model. Rules can be easily developed, if the process to be controlled is well known. Fuzzy controller consist of 4 units:-

- 1) *Fuzzification*: Here, input data is classified into linguistic sets.
- 2) *Knowledge base*: Here, in this block rules are written in If...then format.
- 3) *Inference engine*: Decision making is performed in this block.
- 4) *Defuzzification*: In this block, crisp signal is produced from fuzzy control action available.

Fuzzy control rules can be derived easily, as it completely based on designer’s experience such as what to do if system’s output is higher or lower & based on following criteria:-

If the Converter’s actual output is not reference value and also actual output is distant from reference point the change in Duty cycle must be large, so that the actual output moves rapidly towards reference point.

If the Converter’s actual output is less than desired value then change in Duty cycle must be higher.

If the Converter’s actual output is more than desired value then change in Duty cycle must be lower.

For Designing fuzzy logic controller, here two inputs are used i.e. error and change in error, While a single controlled output.

$$\text{Error} = \text{Reference value} - \text{Actual value}$$

During fuzzification, five-membership functions for inputs and outputs are assigned they are BP, SP, ZO, SN, BN.

Where BN= Big Negative, SN= Small Negative, ZO= Zero equal, SP= small Positive, BP= Big Positive. Fuzzy control rule for an ordinary fuzzy logic controller is shown on Table 1.

TABLE I
 FUZZY CONTROL RULES FOR AN ORDINARY FUZZY LOGIC CONTROLLER

Error Change in Error	BN	SN	ZO	SP	BP
BP	ZO	SP	BP	BP	BP
SP	SN	ZO	SP	BP	BP
ZO	BN	SN	ZO	SP	BP
SN	BN	BN	SN	ZO	SP
BN	BN	BN	BN	SN	ZO

C. Fuzzy Logic for FUZZY-PID Hybrid Controller

As the name suggests, it is one of hybrid controller, which is designed to utilize the characteristics or qualities of two or more techniques together. Conventional PID controller does not give acceptable performance for systems with uncertain dynamics, time delays and non-linearity.

Here, fuzzy system is used for calculating the parameter’s values for PID controller such as Proportional, Integral and Derivative gain. The fuzzy module used is different as taking two inputs i.e. error and change in error while providing 3 different output. These 3 controlled output is nothing but the parameter’s value that is to be given to PID controller. The structure of Module is shown in figure 4.

International Journal for Research in Applied Science & Engineering Technology (IJRASET)

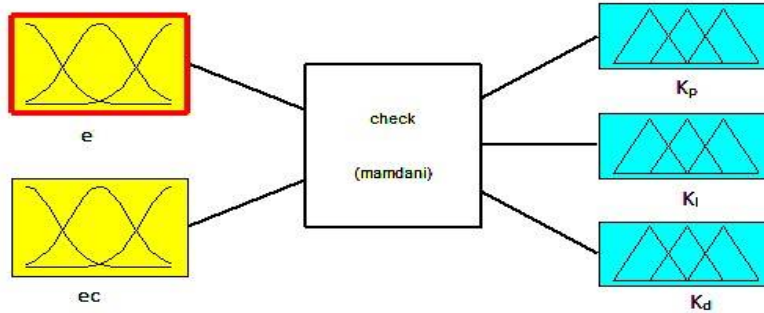

Fig.4 Two Input-Three Output Fuzzy Logic Controller Structure

For Error and change in Error signals 5-Gaussian membership functions is used and linguistic variables as :{ BP, SP, ZO, SN, BN} and range is limited between {-1 TO +1}.Where BN=Big Negative, SN= Small Negative, ZO= Zero equal, SP=small Positive, BP=Big Positive.

While the output signals also consist of 5- Gaussian membership function and linguistic variables as :{ ZO, SM, EM, BM, VL} and range is different for all 3 outputs.

Individually fuzzy control rules for calculating proportional gain, Integral gain and Derivative gain respectively are obtained and shown on tables 2, 3, 4 respectively.

TABLE III
 FUZZY CONTROL RULES FOR CALCULATING PROPORTIONAL GAIN

		Error				
		BN	SN	ZO	SP	BP
Change in	BN	ZO	ZO	SM	SM	EM
	Error	SN	ZO	SM	SM	EM
	ZO	SM	SM	EM	BM	BM
	SP	SM	EM	BM	BM	VL
	BP	EM	BM	BM	VL	VL

TABLE IIIII
 FUZZY CONTROL RULES FOR CALCULATING INTEGRAL GAIN

		Error				
		BN	SN	ZO	SP	BP
Change in	BN	VL	VL	BM	BM	EM
	Error	SN	VL	BM	BM	EM
	ZO	BM	BM	EM	SM	SM
	SP	BM	EM	SM	SM	ZO
	BP	EM	SM	SM	SM	ZO

International Journal for Research in Applied Science & Engineering Technology (IJRASET)

TABLE IVV
 FUZZY CONTROL RULES FOR CALCULATING DERIVATIVE GAIN

			Error			
		BN	SN	ZO	SP	BP
Change in	BN	BM	ZO	ZO	ZO	BM
Error	SN	EM	ZO	SM	SM	EM
	ZO	EM	SM	SM	SM	EM
	SP	EM	EM	EM	EM	EM
	BP	VL	BM	BM	BM	VL

D. Artificial Neural Network with PID Controller

Artificial neural network is a model consist of artificial neurons which process the information from input and provides controlled output. Here, ANN is used for computing the gains values of PID controller so that change in duty cycle is produced. The ANN structure in a closed loop with a single neuron is shown in figure 5.

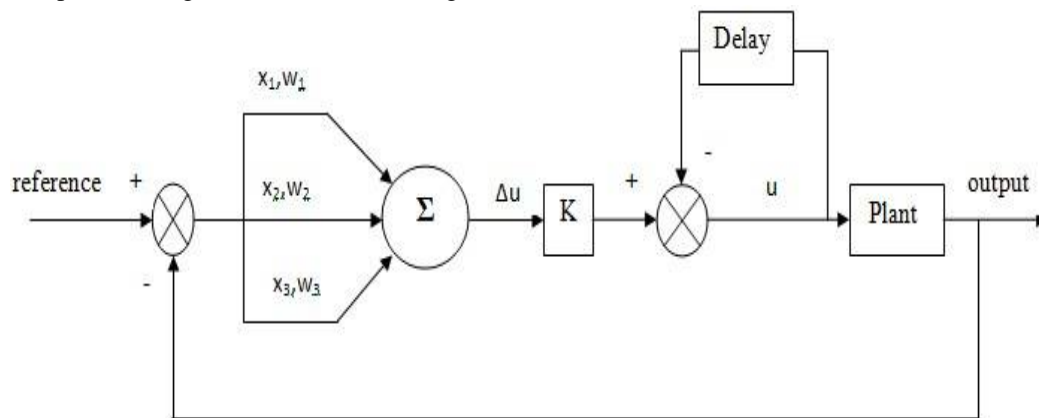

Fig.5 Single Neuron ANN Structure

Weights w_1, w_2, w_3 will acts as a PID controllers gains. The weights are modified by the help of learning algorithms to achieve desired value.

$$x_1(k) = e(k) - e(k-1) \dots \dots \dots (10)$$

$$x_2(k) = e(k) \dots \dots \dots (11)$$

$$x_3(k) = e(k) - 2e(k-1) - e(k-2) \dots \dots \dots (12)$$

Now, weights are multiplied with these error signals and input given to single neuron. Output of Neuron is given by:

$$u(k) = u(k-1) + K \sum_{i=1}^3 w_i(k) x_i(k) \dots \dots \dots (13)$$

Where, K is constant from which we can increase or decrease the speed of system's response. Tuning a PID controller by ANN involves steps such as:

Step1: For the weights, select any Random values.

International Journal for Research in Applied Science & Engineering Technology (IJRASET)

Step2: Now Error is calculated which is the Difference of Reference value and Actual value.

Step3: The Error signal can be used for calculating gain of PID controller which in turn decided by Supervised Data Learning Algorithm.

Step 4: Single Neuron's output i.e. Δu for obtaining better response must be multiplied with a gain k .

Step5: Proportional gain, Integral gain and Derivative gain respectively are obtained by updating the weights.

IV.SIMULATION RESULTS

For finding the proposed controller i.e. PID-NN (PID controller with neural network) accuracy, its needs to be investigate by using mat lab/Simulink software. Different controllers are tested with Buck Converter individually and results are shown in a comparison table from that we could easily find the merits & demerits of every controller's proposed.

In this Paper, a Buck Converter is controlled by different controllers such as Conventional PID controller, an ordinary Fuzzy Logic Controller, a hybrid Fuzzy-PID controller& a hybrid PID-NN controller are simulated separately. Also, output voltage waveform regarding with different controllers are shown in figures 6, figure 7, and figure 8 respectively.

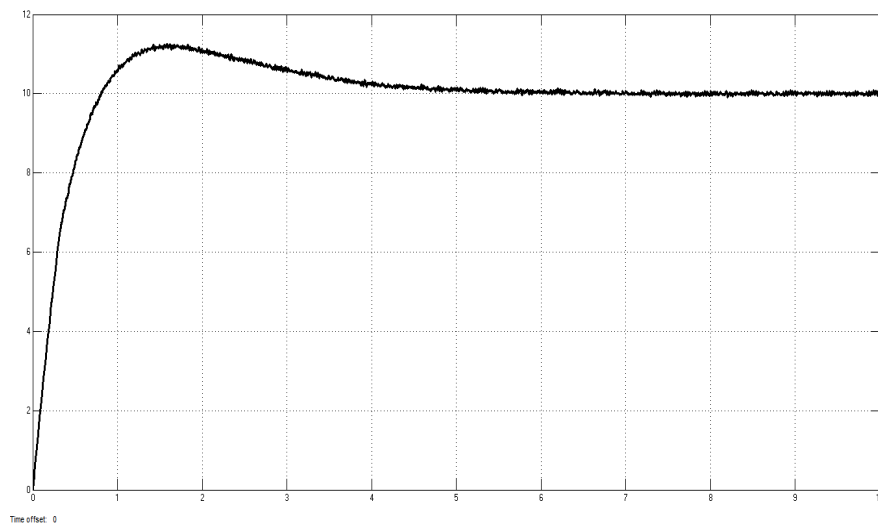

Fig.6 Output Voltage Waveform of PID Controller

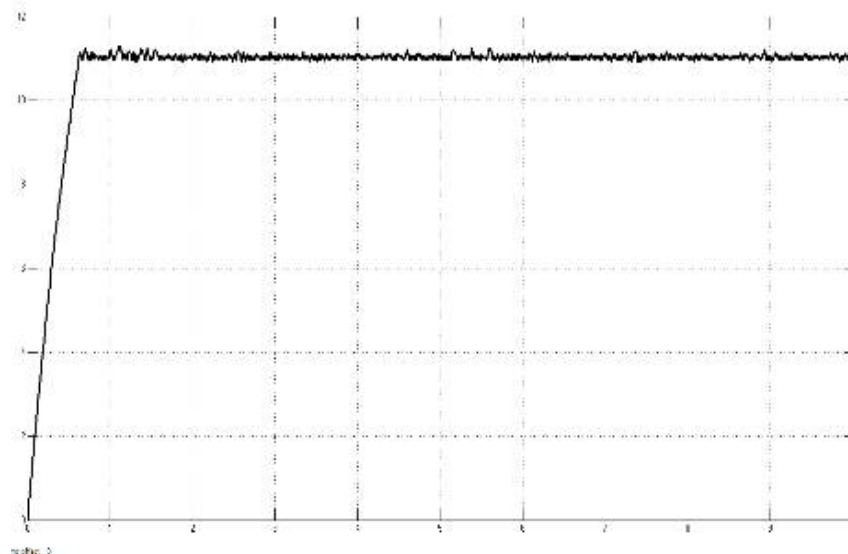

Fig.7 Output Voltage Waveform of an Ordinary Fuzzy Logic Controller

International Journal for Research in Applied Science & Engineering Technology (IJRASET)

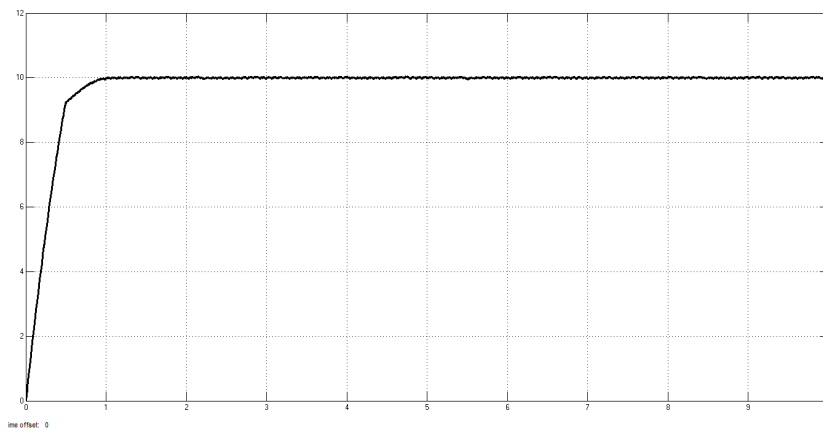

Fig.8 Output Voltage Waveform of a FUZZY-PID Hybrid Controller

In the next step, we have proposed NN-PID controller shown in figure 9 and its output voltage waveform in figure 10 shown. The desired output voltage is equal to 10 Volt. Firstly, voltage at output is compared with the reference voltage thereby error and change in error are obtained.

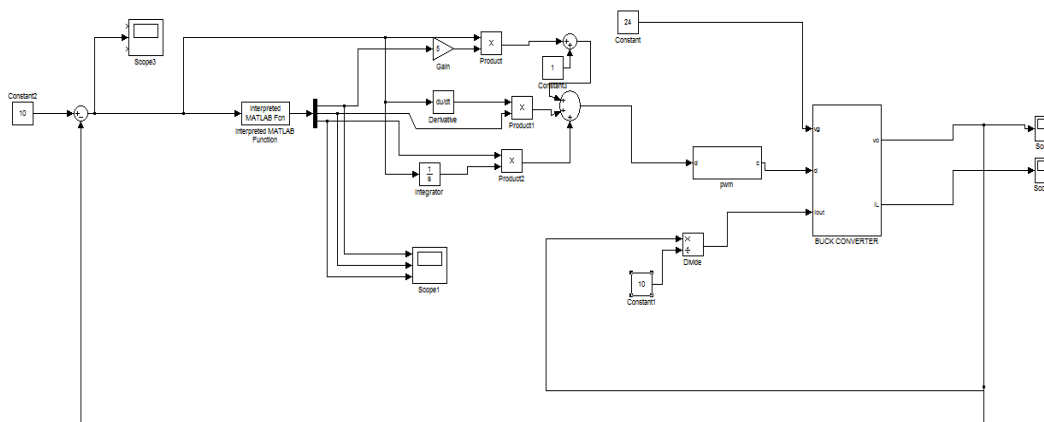

Fig.9 Simulated Model of NN-PID Controller for Controlling Buck Converter

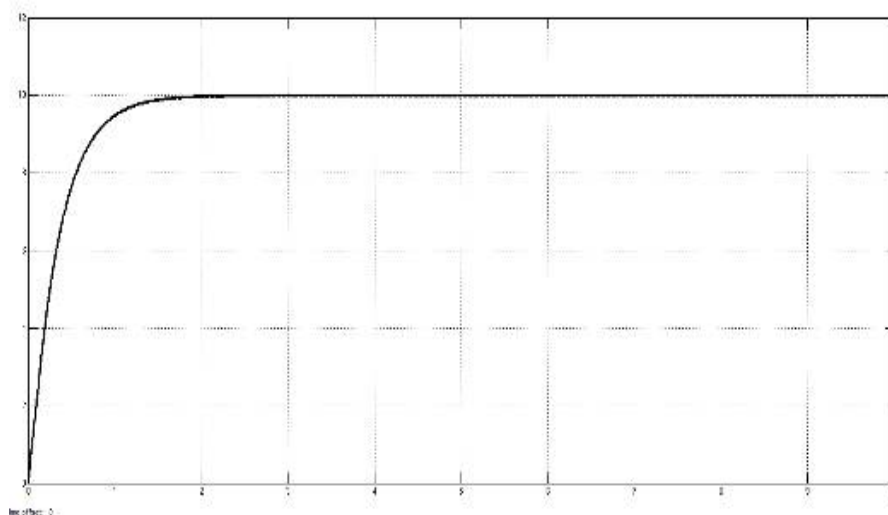

Fig.10 Output Voltage Waveform of NN-PID Controller

International Journal for Research in Applied Science & Engineering Technology (IJRASET)

A single neuron ANN structure is used for tuning of PID and corresponding duty ratio command is obtained. The comparison of all controllers magnified view as shown in figure 11, the proposed NN-PID controllers provides lower Steady state Error & overshoot but having higher rise time & settling time.

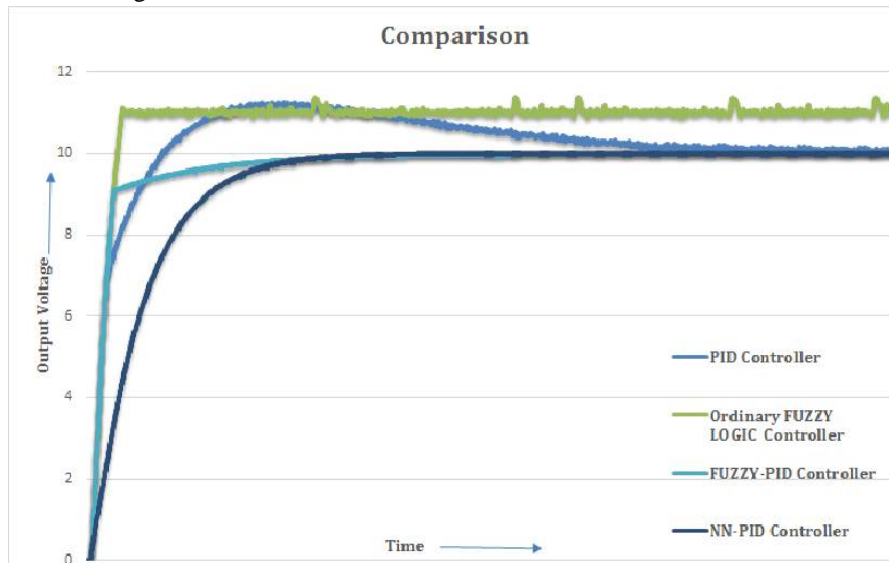

Fig.11 Comparison of Output Voltage Waveform of Various Controllers

V. CONCLUSIONS

PID controllers are the most suitable controller that are extensively used in industries process. The objective of proposed controller i.e. PID-NN controller to provide more accuracy with less error to the system's response. Here, the neural network with its adaptability & strong learning ability calculates the different parameters gain of PID controller and hence, output response of system is improved. The comparison table is shown below.

TABLE V
 COMPARISON OF RESPONSES OF VARIOUS CONTROLLERS

Types of Controller's	Rise time	Settling time	overshoot	Steady state error
PID	0.67 sec	5 sec	10.5 %	< 2.5%
FUZZY	1.2 sec	2 sec	10%	<3%
FUZZY-PID	0.6 sec	1.5 sec	0.5 %	< 0.2%
PID-NN	0.8 sec	2 sec	0.2%	< 0.1%

After Analysing the output voltage waveform with different controllers, a comparison table is prepared and from that we can conclude that the proposed controller have less Error i.e. highly accurate but response is little slow.

A. Future Scope

In order to use the advantages of fuzzy logic it may combine with neural network for improving rise time and peak time and also

International Journal for Research in Applied Science & Engineering Technology (IJRASET)

many algorithms can be used for improving the transient response of system such as ANFIS, Genetic Algorithms, soft computing technics etc.

VI. ACKNOWLEDGMENT

I would like to thank my supervisor **Mr. Dushyant Singh**, Department of Electrical Engineering for his immense support and enlightened guidance for my paper which I have developed as a M.E. IVth semester student. I am very grateful for the inspiring discussions with all my faculties. Their valuable support and path-guiding suggestions have helped me to develop this paper. I am thankful to **Mr. Prashant Choudhary**, HOD, Department of Electrical Engineering for giving thoughtful suggestions during my work.

REFERENCES

- [1] Liping Guo, John Y. Hung, and R. M. Nelms, "Evaluation of dsp- based pid and fuzzy controllers for dc-dc converters", IEEE Transactions on Industrial Electronics, vol. 56, Jun. 2009, pp.2237-2248, doi. 10.1109/TIE.2009.2016955.
- [2] Nguyen Gia Minh, Thao, Mai, Tuan Dat, Tran Cong Binh, Nguyen Huu Phuc, "PID-Fuzzy Logic Hybrid Controller for Grid-Connected Photovoltaic Inverters", International Forum on Strategic Technology (IFOST), Oct.2010, pp.140-144, doi. 10.1109/IFOST.2010.5668024.
- [3] V. S. C. Raviraj and P. C. Sen, "Comparative Study of Proportional-Integral, Sliding Mode, and Fuzzy Logic Controllers for Power Converters", IEEE Transactions on Industry Applications, vol. 33, mar/apr-1997, pp. 518-524, doi. 10.1109/28.568018.
- [4] Tobias Geyer, Georgios Papafotiou and Manfred Morari, "Constrained Optimal Control of the Step-Down DC-DC Converter", IEEE Transactions on Power Electronics, Vol. 23, sept. 2008, pp. 2454 – 2464, doi. 10.1109/TPEL.2008.2002057.
- [5] Meng Joo Er, and Ya Lei, "Hybrid Fuzzy Proportional-Integral Plus Conventional Derivative Control of Linear and Nonlinear Systems", IEEE Transactions on Industrial Electronics, vol.48, dec.2001, pp.1109-1117, doi. 10.1109/41.969389.
- [6] K. S. Tang, K. F. Man, G. Chen, and S. Kwong, "An Optimal Fuzzy PID Controller", IEEE Transactions on Industrial Electronics, vol.48, aug.2001, pp.757-765, doi. 10.1109/41.937407.



10.22214/IJRASET



45.98



IMPACT FACTOR:
7.129



IMPACT FACTOR:
7.429



INTERNATIONAL JOURNAL FOR RESEARCH

IN APPLIED SCIENCE & ENGINEERING TECHNOLOGY

Call : 08813907089  (24*7 Support on Whatsapp)