



# IJRASET

International Journal For Research in  
Applied Science and Engineering Technology



---

# INTERNATIONAL JOURNAL FOR RESEARCH

IN APPLIED SCIENCE & ENGINEERING TECHNOLOGY

---

**Volume: 4      Issue: X      Month of publication: October 2016**

**DOI:**

**[www.ijraset.com](http://www.ijraset.com)**

**Call:  08813907089**

**E-mail ID: [ijraset@gmail.com](mailto:ijraset@gmail.com)**

# A Design to Improve Performance of Sheet Metal Dies

V. Praveen<sup>1</sup>, V. Vignesh<sup>2</sup>

<sup>1</sup>Assistant Professor in department of mechanical Engineering, Apollo Engineering College

<sup>2</sup>II year student, Petroleum engineering & Technology, ACT Campus, Anna University

**Abstract**— This paper presents design of sheet metal die mould for protection cap. The review provides information about various design parameters concerned with Sheet Metal Die design. In order to make a product of sheet metal requires measurement & analysis of sheet metal parts. Due to this range of possible errors occurring in manufacturing can be greatly reduced. Regarding the concept of Die mould design, various research work can be carried out such as Tribological simulation for invalidation analysis of mould, Quality function development, DFMA, mold delamination & die fracture analysis. Several approaches are taken into account such as virtual prototyping approach to mould design. In virtual prototype is generated by combining automated and interactive approaches. In existing die mould protection cap, There are several problems regarding selection of alloy steel, shape error of sheet metal die mould product, so it is required to design mould for protection cap & improvement in the existing design is must. An effort is made in this paper to review various techniques of designing mould for protection cap..

**Keywords**— Sheet metal parts, Die & mould, Invalidation analysis, Tool path planning, Tribology

## I. INTRODUCTION

As mold design is a complex process involving in many decision factors, it is difficult to insure both mold reusability and meeting manufacturing requirements without iteration of evaluating and modifying. In order to machine and assemble the moulds with required functions at first time, the mold designers should perform evaluations on their designs and modify them accordingly. While Accuracy & reliability of other sheet metal Die mould product are less. Chances of shape error occurrence are more due to poor machining. There are new methods which are developed & technology is advancing in order to improve the quality of sheet metal die mould product. This product made specifically and can be suited for customer needs and requirements. There are several problems regarding selection of alloy steel, shape error of sheet metal die mould product. In order to overcome this difficulty, analysis of product is needed & due to that analysis sheet metal die mould product will find with greater accuracy & high precision.

## II. LITERATURE REVIEW

### A. Measurement & Analysis of sheet metal parts

Wei Shao et al have published paper on “A Framework on Measurement & analysis of sheet metal parts”. The Author has carried out the work done on measurement of sheet metal parts. It can employed online measurement system with improved accuracy, flexibility and advanced measuring efficiency advantages. Shape error analysis is used to assure quality and to reduce manufacturing cost. The main purpose of system is to inspect sheet metal parts for avoiding range of possible errors. The overall system consists of two modules. 1] Measurement module: Its programmable machine in which online 3 D shape measurement system is employed. 2] Shape analysis module: It consists a collection of computational tools in which graphical user interface can be employed to perform measurement path generation, error analysis.

There are stages of shape analysis that author can employed including pre-processing & shape error analysis.

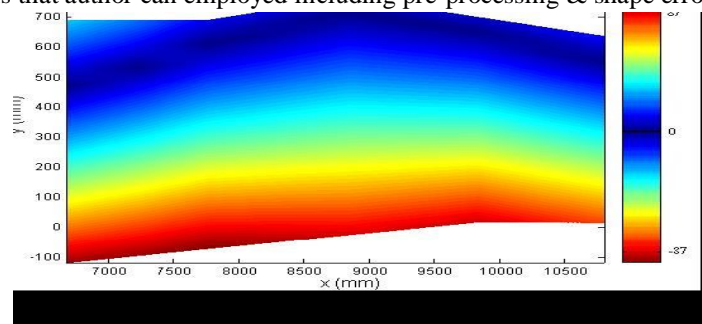

## International Journal for Research in Applied Science & Engineering Technology (IJRASET)

(a) error distribution result before surface analysis

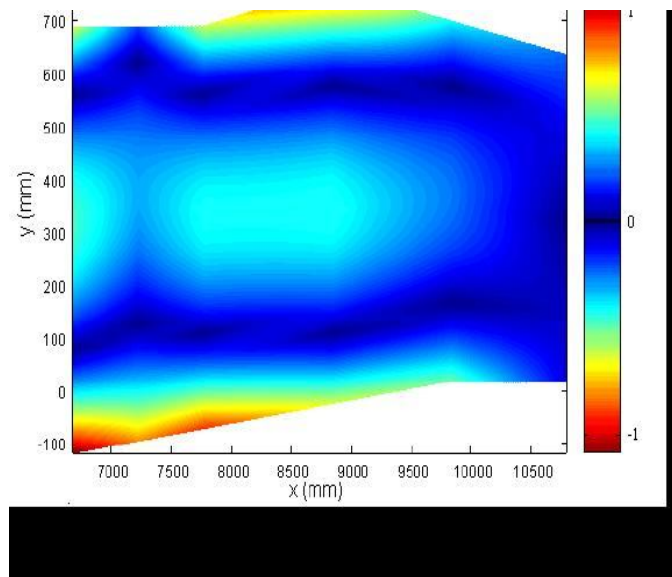

(b) Error distribution result after surface analysis

Error between surface data & standard cad data as shown in fig. the method offered in this paper can available perform matching of surfaces with CAD models stored in the database, and identify the differences and errors.[1] Author demonstrated the performance of system for analyzing machined aerofoils . From proposed error analysis system can be used for analyzing sheet metal parts for manufacturing applications.

### B. Optimized die design

This researcher wants to develop a die size optimization algorithm based on decision tree to construct the rules between the number of gross dies per wafer, mask utilization die feature including length, width, and area. Research framework is to extract optimal die size rules with better accuracy and lower complexity, this research constructed a data mining framework based on two-phase decision tree to explore the relationship between the numbers of gross dies per wafer and mask utilization to the size of integrated circuit die including length, width, and area. In particular, the proposed framework consists of four steps: problem definition, data preparation, two-phase decision tree construction, and result validation and interpretation.

1) *Empirical Study*: An empirical study has been done for validation by using transformed data from a fab in Taiwan.

To find the optimal die layout with the gross die number per wafer, exposure times, and the corresponding die size including die length, die width, and die area as the inputs for data mining. There are three important criteria for evaluating a decision tree-size, accuracy understand ability The proposed two-phase decision tree data mining framework is designed to extract rules from huge continuous data. The empirical results showed that [2] it effectively reduced the model complexity and enhanced the predicted accuracy. The pruning method can efficiently prune the tree to the smaller size and better accuracy of extracting rules. Finally, the IC designer can easily use these extracting rules to design optimal integrated circuit die size for maximizing the gross die number per wafer and reducing the fabrication cost at the same time.

### C. Numerical Stimulation and Optimization in Sheet Metal Forming

According to author, study of this paper allows the production of optimized components specially developed for their future function, which cannot be made from conventionally rolled sheet metal. The research aims at showing that the two processes, i.e. flexible rolling and high-pressure sheet metal forming, can be well represented in finite element simulations.

Lightweight constructions made out of tailor rolled blanks (TRB) and advanced manufacturing technologies like the high-pressure sheet metal forming (HPSMF) help to reach goals of Ecological awareness and to reduce economic pressure in the industry to decrease the weight of cars and achieve a higher product quality while decreasing the cost of the production.

## International Journal for Research in Applied Science & Engineering Technology (IJRASET)

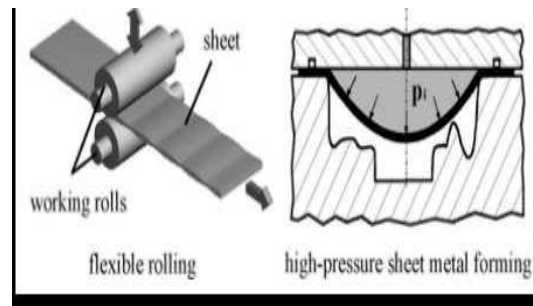

Process chain of flexible rolling and high- pressure sheet metal forming

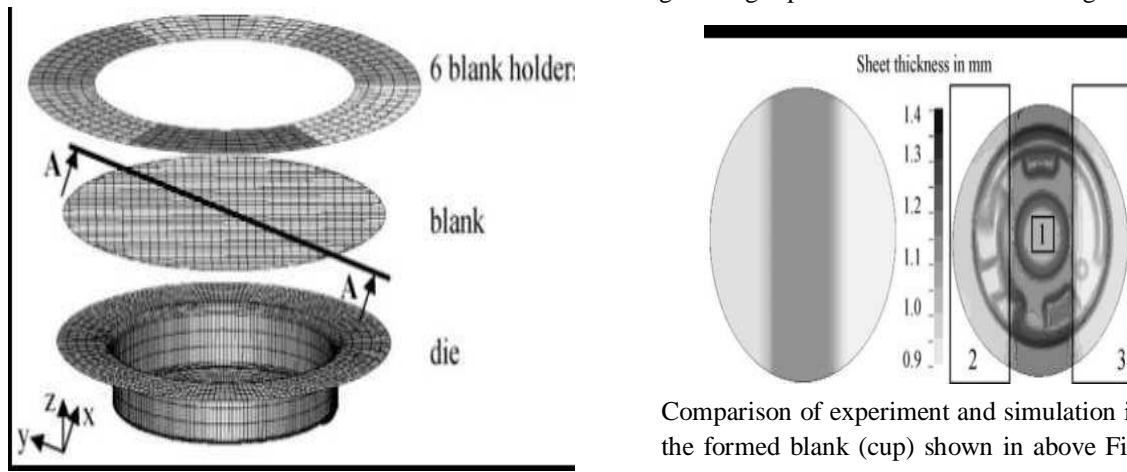

Comparison of experiment and simulation in the cross section A-A of the formed blank (cup) shown in above Fig. with and without spring back

### D. A virtual prototyping approach to mold design

The zouping yin et al represents a virtual prototyping environment supporting mold design in which the mold virtual prototype is generated by combining automated and interactive approaches. The generated virtual prototype can be input into a virtual reality environment for visualisation and design evaluation by performing virtual assemble and physical-based injection moving simulation. By creating a VP that allows for accessing assemblability early in mold design process, a design can be modified to accommodate assemblability and demouldability before jinjal stages of design are reached [4].

1) *Framework*: The section presents an overall structure of our VP environment supporting mold design. As shown in Fig., the VP framework identifies the abstract modules that need to be developed to realize such VP environment. The main activities involved in VP are virtual prototype generation and processes simulation. The virtual prototype of mold is the computer representation of mold assembly in the virtual environment; it can be generated automatically or interactively based on the geometry of the molding and injection process parameters [4]

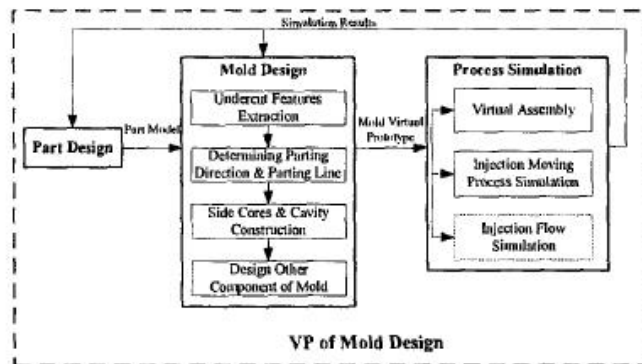

Fig. 1. Overall framework of VP for mold design

## International Journal for Research in Applied Science & Engineering Technology (IJRASET)

### E. Tribological Simulation for Invalidation Analysis of Mould

Theoretical prediction of effective properties for materials is very important not only to analysis and optimization of material performance, but also to mould material validation. The effect of tribology problems in mould invalidation is obtained. The importance of tribology design is discussed in the mould design. The tribological problem was discussed for the mould design by invalidation analysis of mould.

Die wear can occur locally during cold-forming processes. Particularly, wear affects the economics of the forming process, the tolerances of the formed parts, the metal flow, and the die life. For this reason, a study on die wear is required to preserve the reliability of the forming tool and to predict the chance of repairing or changing the die. [5] Considering the main factors with important influence on tribological parameters, the support vector machine (SVM) model is established, which can really meet the functional requirements in terms of structural, thermal or other prescribed properties

The goal of the project was to demonstrate, that a combination of these two innovative production techniques, flexible rolling and HPSMF, can be used to manufacture products with an optimized thickness distribution for their final application. Therefore the sheet thickness distribution of the TRB was adapted by computer aided optimization using finite element simulations. Afterwards the optimized TRBs were used for high-pressure sheet metal forming.

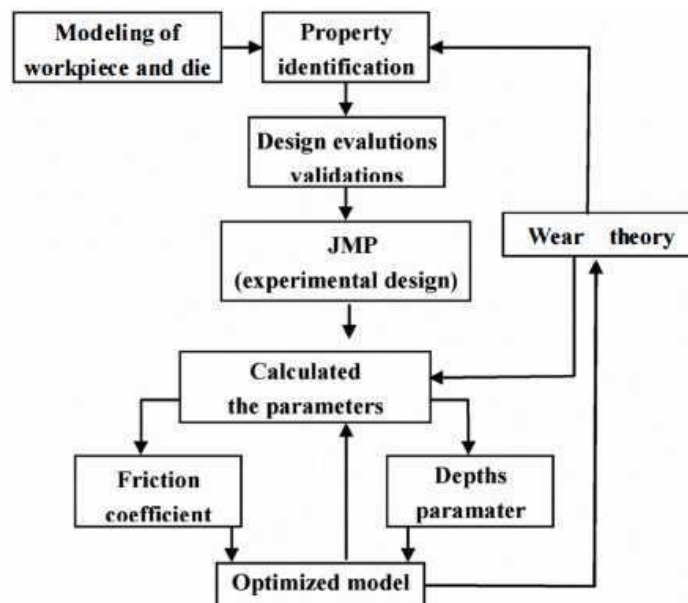
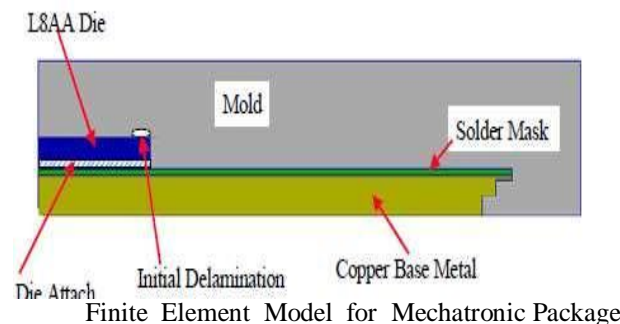

Figure 2. The process flow of die-related design

### F. Die Fracture Analysis & Delamination

In mechatronic packages Mold delamination and die cracking have been observed after assembly. With some mold compound, die backside has large delaminated areas, while with other mold compound, delamination stops early but die cracks. Finite element analysis, incorporated with interface fracture mechanics method, was conducted to understand these phenomena. Impact of mold material properties and package geometry on post-assembly delamination was evaluated [6].



## International Journal for Research in Applied Science & Engineering Technology (IJRASET)

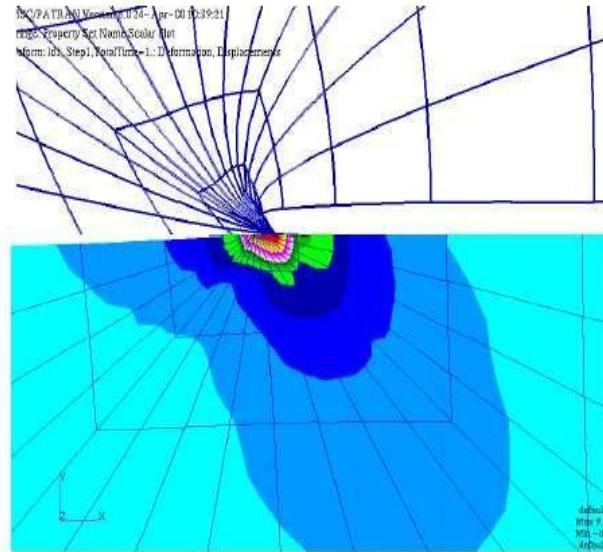

There was high stress concentration at the interface crack tip, which might cause die cracking. Mold compound with higher effective CTE tends to induce larger delaminated area. However, most of the energy will be released when interface cracks finally stop, no die cracking will occur.

### G. Low cost strategy for sheet metal product

This paper is illustration of real sheet metal product, which manufacturing is really challenging and many problems occur in production. In this paper given some point of views, which should be take into consideration before the part can be produced without or some minimal problems. The frame of this work is a cost-oriented DFMA-approach which aims to control and manage both the product design and manufacturing process together with its costs[7]. The purpose of this paper is to study variables which should be considered when manufacturing of a certain demanding product is transferred successfully in global networks accordingly low cost strategy. In the case of studied steel metal product, there are several methods and tools to perform these manufacturing actions. The material properties and the quality requirements of final product define more or less the processing methods, regardless of its final manufacturer and location. The final product should have planar straightness and good surface quality.

### III. CONCLUSIONS

The paper reveals that online measurement system with improved accuracy, flexibility can be employed for measurement & analysis of sheet metal parts. A framework done in this paper aims to analysis shape error in order to improve quality assurance [1].

Extraction of optimal die size rules with better accuracy and lower complexity can be illustrates in this paper. Author gives several references to discuss Die designing with characteristic features of optimization [2].

The researcher demonstrates combination of two innovative production techniques, flexible rolling and HPSMF, can be used to manufacture products. These two techniques are used for thickness distribution through optimization [3].

Virtual prototype is new approach uses in mold designing& is generated by combining automated and interactive approaches. The generated virtual prototype can be input into a virtual reality environment for visualisation and design evaluation [4].

In order to meet the functional requirements in terms of structural, thermal or other prescribed properties ,support vector machine (SVM) model is established by .Considering the main factors with important influence on tribological parameters[5].

The delamination starts at die edge and propagates toward the centre of the die. Due to high stress concentration at the interface crack tip, causes die cracking. Researcher gives the idea regarding mold delamination & die fracture by making analysis on Mechatronic packages [6].

DFMA-approach used for controlling and managing both the product design and manufacturing process together with its costs. The purpose of this paper is to study variables which should be considered when manufacturing of a certain demanding product is transferred successfully in global networks accordingly low cost strategy [7].

# International Journal for Research in Applied Science & Engineering Technology (IJRASET)

## REFERENCES

- [1] Wei Shao, Junjie Guo, Awei Zhou, "A Framework of Measurement & Analysis of Sheet Metal Parts" 2009 IEEE DOI 10.1109/ICICTA.2009.323
- [2] Chen-Fu Chien./ Chia-Chih Liu/ Chia-Yu Hsu/ Hong-Shing Chou/ Chih-Wei Lin1,
- [3] "Optimize Die Size Design to Enhance OWE for Design for Manufacturing" 1-4244-1142-4/07/ ©2007 IEEE
- [4] Yang An, "Numerical Stimulation and Optimization of Process Chain in High Pressure Sheet Metal Forming" 2011 Third International Conference on Measuring Technology and Mechatronics Automation
- [5] Zhouping Yin, Han Ding, S. K. Tso and Youlun Xiong , "A virtual prototyping approach to mold design" 0-7803-5731-0B9/ 01999 IEEE.



10.22214/IJRASET



45.98



IMPACT FACTOR:  
7.129



IMPACT FACTOR:  
7.429



# INTERNATIONAL JOURNAL FOR RESEARCH

IN APPLIED SCIENCE & ENGINEERING TECHNOLOGY

Call : 08813907089  (24\*7 Support on Whatsapp)