



IJRASET

International Journal For Research in
Applied Science and Engineering Technology



INTERNATIONAL JOURNAL FOR RESEARCH

IN APPLIED SCIENCE & ENGINEERING TECHNOLOGY

Volume: 4

Issue: X

Month of publication: October 2016

DOI:

www.ijraset.com

Call:  08813907089

E-mail ID: ijraset@gmail.com

**International Journal for Research in Applied Science & Engineering
Technology (IJRASET)**

Wavelength Division Multiplexing Optical Networks

Anuradha Bhasin¹, Monika Kaushik², Usha Sharma³

Department of ECE, GGSIP University, BPIT Rohini Sector -17 DELHI-89, INDIA

Abstract: *Optical wavelength division multiplexing technology has been deployed at a very rapid rate. In this paper technical review of wavelength division multiplexing (WDM) transmission technique i.e. along with the latest development trends on WDM optical networks is given. Recent trends in WDM optical networks along with the challenges and limitations of the WDM architectures have also been discussed.*

Keywords: *WDM, Communication channel, fibre optic technology, efficiency, rate, multiplexing*

I. INTRODUCTION

In order to meet the networking demands of the next decade when more and more users start to use the data networks and their usage pattern evolve to include more and more bandwidth intensive networking applications such as data browsing on world wide web, java applications etc. there emerges a need for very high bandwidth transport network facilities, whose capabilities are much beyond those that of high speed ATM networks can provide, then the only solution is Fiber optic technology.

The key in designing optical communication networks is to introduce concurrency among multiple user transmissions into the network architectures and protocols. In an optical communication network this concurrency may be provided according to wavelength [wavelength division multiplexing]. Specifically, WDM is the current favorite transmission technology for long haul communications in optical communication networks. Under WDM the optical spectrum is carved up into a number of non-overlapping wavelength bands with each wavelength supporting a single communication channel operating at whatever rate one desires.

A lot of research work has been carried out on the development of optical WDM networks [5-10]. A number of experimental prototypes have been and are currently being developed, deployed and tested. A study [11] compared the relative cost of upgrading the transmission capacity of a point to point transmission link from OC-48(2.5 Gb/s) to OC-192(10Gb/s) via the following three possible solutions, (a) Installation of additional fibers and terminating equipment (b) A four channel WDM solution, which includes a WDM multiplexer to combine four independent data streams each on unique wavelength, send them on a fiber and then demultiplexer at receiver (c) OC-192, a higher electronic speed solution. The analysis showed that for distances lower than 50 km the multifiber solution was the least expensive but for distances longer than 50 km WDM solution cost was the least.

Current development activities indicate that WDM network will be deployed as a backbone network for large regions. WDM is turning out to be a more cost effective alternative compared to laying more fibers.

In this paper we have provided a technical review on WDM transmission technique giving a detailed description of different wavelength division multiplexing techniques. Finally we have discussed the progress in WDM technologies along with their limitations.

II. WAVELENGTH-DIVISION MULTIPLEXING (WDM)

In fiber-optic communications, wavelength-division multiplexing (WDM) is a technology which multiplexes a number of optical carrier signals onto a single optical fiber by using different wavelengths (i.e., colors) of laser light. This technique enables bidirectional communications over one strand of fiber, as well as multiplication of capacity. The term *wavelength-division multiplexing* is commonly applied to an optical carrier typically described by its wavelength.

International Journal for Research in Applied Science & Engineering Technology (IJRASET)

wavelength-division multiplexing (WDM)

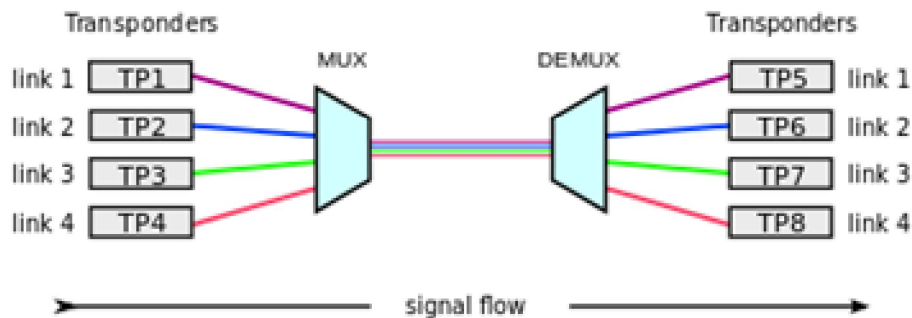

Fig1: A schematic diagram of WDM

A WDM system (Fig1) uses a multiplexer at the transmitter to join the signals together, and a demultiplexer at the receiver to split them apart. The first WDM systems combined only two signals. Modern systems can handle up to 160 signals and can thus expand a basic 10 Gbit/s system over a single fiber pair to over 1.6 Tbit/s. The first WDM systems were two-channel systems that used 1310nm and 1550nm wavelengths. The multi-channel systems that used the 1550nm region – where the fiber attenuation is lowest. WDM systems are popular with telecommunications companies because they allow them to expand the capacity of the network without laying more fiber. By using WDM and optical amplifiers, they can accommodate several generations of technology development in their optical infrastructure without having to overhaul the backbone network. Capacity of a given link can be expanded simply by upgrading the multiplexers and demultiplexers at each end.

Most WDM systems operate on single-mode fiber optical cables, which have a core diameter of 9 μm . Certain forms of WDM can also be used in multi-mode fiber cables (also known as premises cables) which have core diameters of 50 or 62.5 μm . Thus by allowing multiple WDM channels coexist on a single fiber one can tap into the huge fiber bandwidth, with the corresponding challenges being the design and development of network architectures, protocols and algorithms.

A. Coarse wavelength division multiplexing CWDM

Coarse wavelength division multiplexing (CWDM) typically has the capability to transport up to 16 channels (wavelengths) in the spectrum grid from 1270 nm to 1610 nm with a 20 nm channel spacing. Each channel can operate at either 2.5, 4 or 10 Gbit/s. CWDM uses increased channel spacing to allow less sophisticated and thus cheaper transceiver designs. CWDM can not be amplified as most of the channels are outside the operating window of the Erbium Doped Fibre Amplifier (EDFA). This results in a shorter overall system reach of approximately 100 kilometers. However, due to the broader channel spacing in CWDM, and use of cheaper un-cooled lasers, CWDM is the cost efficient transport in optical networks.

B. Dense wavelength division multiplexing (DWDM)

Dense wavelength division multiplexing (DWDM) refers to optical signals multiplexed within the 1550 nm band. DWDM has the capability to transport up to 80 channels (wavelengths) in the Conventional band or C band spectrum, with all 80 channels in the 1550 nm region. DWDM takes advantage of the operating window i.e. 1525–1565 nm (C band), or 1570–1610 nm (L band) of the Erbium Doped Fibre Amplifier (EDFA) to amplify the optical channels and extend the operating range of the system to over 1500 kilometers. This denser channel spacing requires tighter control of the wavelengths. Hence, cooled lasers i.e., temperature stabilized lasers are used to provide the needed channels count in DWDM. DWDM is economical for long-haul applications. Recent innovations in DWDM transport systems include pluggable and software-tunable transceiver modules capable of operating on 40 or 80 channels. This dramatically reduces the need for discrete spare pluggable modules, when a handful of pluggable devices can handle the full range of wavelengths.

C. Comparison of DWDM and CWDM

DWDM systems have to maintain more stable wavelength or frequency than those needed for CWDM because of the closer spacing

International Journal for Research in Applied Science & Engineering Technology (IJRASET)

of the wavelengths. Precision temperature control of laser transmitter is required in DWDM systems to prevent "drift" off a very narrow frequency window of the order of a few GHz. In addition, since DWDM provides greater maximum capacity it tends to be used at a higher level in the communications hierarchy than CWDM, for example on the Internet backbone and is therefore associated with higher modulation rates, thus creating a smaller market for DWDM devices with very high performance. These factors of smaller volume and higher performance result in DWDM systems typically being more expensive than CWDM. Because of the high costs involved, DWDM is only economical for long-haul applications. Thus, Dense Wavelength Division Multiplexing (DWDM) is the technology of choice for transporting extremely large amounts of data traffic over long distances in telecom networks. Optical networking and especially the use of DWDM technology has proven to be the optimal way of combining advanced functionality, which can cope with the bandwidth explosion from the access network. Whereas, Coarse Wavelength Division Multiplexing (CWDM) is the technology of choice for cost efficiently transporting large amounts of data traffic in telecoms or enterprise networks over short distances. Optical networking and especially the use of CWDM technology has proven to be the most cost efficient transmission for shorter distances.

III. RECENT DEVELOPMENTS IN WDM NETWORKS

Newer approaches and technologies are constantly under development to potentially increase the effectiveness of WDM networks. In this paper two new approaches are briefly reviewed.

- A. All wave fiber: Recent developments in fiber optics have expanded the usable fiber bandwidth. A new type of fiber called all wave fiber has been designed. This fiber does not have the 1385nm water peak window which the conventional fiber has. The conventional fiber has the maximum attenuation at 1385nm and the usable optical spectrum extends from 1440nm to 1625nm. The all wave fiber has low attenuation region extending from 1335nm to 1625nm, thereby supporting 300 channels via WDM in CDWM having the spectrum grid from 1270 nm to 1610 nm.
- B. Another new technology is a new type of amplifier device which use erbium doped fiber amplifier (EDFA) as a building block. The normal EDFA has a gain spectrum of 30-40 nm typically in the 1530-1560 nm range. The fibers employ EDFAs for long haul communication via DWDM which takes advantage of the Erbium Doped Fibre Amplifier (EDFA) gain spectrum to amplify the optical channels. The amplifier circuit of ultra-wide band EDFA fully exploits the expanded low attenuation region of all wave fiber.

IV. CHALLENGES

Research on optical network architectures has shown that a sound knowledge of device capabilities and limitations is required to produce realizable and useful technology. WDM optical technology has many desirable characteristics, but it also possesses some not-so-desirable properties. The issues that need to be taken care off are:

A. Physical Layer issues

A signal degrades in quality due physical layer impairments as it proceeds through switches by picking up crosstalk/noise and EDFAs that further amplifies the noise due to which the bit error rate (BER) at the receiving end become unacceptably high. It is required to develop network layer solutions to combat the physical layer impairments like laser shift and dispersion in fiber.

B. Signal regeneration in WDM networks

An optical WDM channel should support end to end communication of data independent of bit rates and signal formats, which is difficult to achieve for long haul transport networks. Moreover the quality of an optical signal degrades as it travels long distances through various optical components. So, long distance communication may require signal regeneration at strategic locations in a WDM network. Further, in a digital network optical signals are amplified by first converting the information stream into an electronic data signal and then retransmitting the signal optically. For this re-clocking of the signal is the challenge faced.

C. IP over WDM

In an IP over WDM network, network nodes employ wavelength routing switches and IP routers. Any two IP routers in this network can be connected together by all optical WDM channel i.e. a light-path and the set of light-paths form a virtual interconnection pattern. Thus, in such an optical WDM network architecture, the failure of a network component such as a fiber can lead to the failure of all the light paths that traverse the failed fiber and this can lead to a significant loss of bandwidth and revenue.

International Journal for Research in Applied Science & Engineering Technology (IJRASET)

Hence, two methods of providing protection have been proposed. 1) provide protection at the WDM layer by setting up backup light path for every primary light-path. 2) provide restoration at the IP layer i.e. overprovision the network so that after a fiber cut the network should be able to carry the same amount of traffic. The significant research work in designing IP over WDM networks is underway.

D. Traffic Grooming in WDM networks

In a WDM network each wavelength can carry several lower rate traffic streams in TDM fashion. Due to heavy traffic demand, which is the integral multiple of timeslot capacity, virtual connections are needed to be added and dropped at the two end nodes of the connection. Hence instead of having an add/drop multiplexor (ADM) on every wavelength at every node, it may be possible to have some nodes on some wavelength where no add/drop is needed on any timeslot. Hence the network cost can be reduced. Moreover savings can be maximized by carefully packing the virtual connections into wavelengths.

V. CONCLUSION

The major scarce resource in telecommunication is *bandwidth* – users want to transmit at high rate and service providers want to offer more services, hence, the need for a faster and more reliable high speed system. For this the only solution is optical fiber communication as data rates possible in optical transmission are usually in Gbps on each wavelength. The wavelength division multiplexing (WDM) allows combination of different wavelengths in a single fiber which means more throughput in one single communication system. Moreover, each wavelength, λ , can carry multiple signals in TDM fashion. This further reduces the cost of hardware. Optical communication has low attenuation compared to other transport system, less propagation delay and more services offered. Moreover, Fiber optic technology can be the future transmission technology by achieving all-optical networks that will reduce optical-to-electrical conversion overhead as optical/electrical/optical conversions introduce unnecessary time delays and power loss. The growth of the internet requires fiber optic transmission to achieve greater throughput. Optical multiplexing finds application in image processing and scanning application.

REFERENCES

- [1] Mukherjee, Optical Communication Networks, New York: Mc Graw-Hill, 1997.
- [2] P. Cochrane, "Foreword," in Optical network Technology, London: chapman & Hail, 1995.
- [3] Ryan, Hankin and Kent (RHK), <http://www.rhk.com/>.
- [4] WDM Forum London, June 1998.
- [5] Special Issue on High Capacity Optical Transport Network, IEEE J. Select. Areas Commun, Volume 16, Sept 1998.
- [6] Special Issue on Multiwavelength Optical Technology and Networks, IEEE/OSA J. Lightwave Technol. ,Volume 14, June 1996.
- [7] Special issue on optical networks, IEEEJ. Select. Areas Commun, vol. 14, June 1996.
- [8] Special Issue on Broadband Optical Networks, IEEE/OSA J. Lightwave Technology vol. 11, May/June 1993.
- [9] Special Issue on Dense Wavelength Division Multiplexing Techniques for High Capacity and Multiple Access Communication System, IEEE J. Select. Areas Commun, vol. 8, Aug. 1990.
- [10] Special issue on WDM Networks , J. High Speed Networks, vol. 4, no. ½, 1995.
- [11] S. Melle, C.P Pfistner, and F. Dinner, "Amplifier and Multiplexing Technologies expand Network Capacity," Lightwave mag., pp. 42-46, Dec. 1995.
- [12] P.E. Green, "Optical Networking update," IEEE J. Select. Areas Commun., vol. 14, pp. 764-779, June 1996.
- [13] Fiber Optics Networks, Englewood Cliffs, NJ: Prentice-hall, 1993.
- [14] C. Fan, "keynote address- Optical Networking: A paradigm shift," in WDM Forum, London, June 1996.
- [15] B. Mukherjee, "WDM- based Local Lightwave Networks- Part 1: single-hop system," IEEE Network Mag., vol. 6, pp. 12-27, May 1992.



10.22214/IJRASET



45.98



IMPACT FACTOR:
7.129



IMPACT FACTOR:
7.429



INTERNATIONAL JOURNAL FOR RESEARCH

IN APPLIED SCIENCE & ENGINEERING TECHNOLOGY

Call : 08813907089  (24*7 Support on Whatsapp)