



IJRASET

International Journal For Research in
Applied Science and Engineering Technology



INTERNATIONAL JOURNAL FOR RESEARCH

IN APPLIED SCIENCE & ENGINEERING TECHNOLOGY

Volume: 4 Issue: XII Month of publication: December 2016

DOI:

www.ijraset.com

Call:  08813907089

E-mail ID: ijraset@gmail.com

Harmonic Reduction in Nonlinear Load using Shunt Active Filter

Niranjana Patro¹, Upendra Tomar²

Department of Electrical Engineering, Vikrant Institute of Technology & Mgmt, Gwalior

Abstract: Active power filter is one of the best solution to reduce the harmonics level in the system. In this paper single phase shunt active filter using sliding mode control is implemented in MATLAB/Simulink. Performance of proposed shunt active filter is analyzed under nonlinear and combined nonlinear and linear load. It is observed that shunt active power filter improves the total harmonic distortion (THD) and power factor under variable load condition.

I. INTRODUCTION

Use of power converters and other nonlinear loads introduces harmonics in network and draws reactive power current from supply. The increase in the reactive power, non-sinusoidal supply voltage and current in power distribution result in many adverse effect such as overheating, poor efficiency, instability, disturbance to other consumer equipment, interference with communication equipment etc. Conventionally passive filters are used to improve power quality but it has various disadvantages of fixed compensation, bulky inductor, no isolation between input and output and resonance [1]. Active power filters are good solution, since they can compensate for reactive power and also solve the harmonic problem. There are two types of active filters: Shunt active power filter & Series active power filter. Shunt APF used to improve shape of source current, whereas series APF can compensate for voltage harmonics and unbalance. Shunt active filter are widely used as they effectively doing compensation and current rating is much less as compared to series filter as it is connected in parallel [2-5]

NONLINEAR loads such as high-power diode/thyristor rectifiers, cycloconverters, and arc furnaces draw nonsinusoidal currents from utility grids. A single low-power diode rectifier used as a utility interface in an electric appliance produces a negligible amount of harmonic current. However, multiple low-power diode rectifiers can inject a large amount of current harmonics into power distribution systems. Active filters are an up-to-date solution to power quality problems. Shunt active filters allow the compensation of current harmonics and unbalance, together with power factor correction, and can be a much better solution than the conventional approach (capacitors for power factor correction and passive filters to compensate for current harmonics). This paper presents the pq theory as a suitable tool to the analysis of non-linear three-phase systems and for the control of active filters. These harmonic producing loads contribute to the degradation of power quality in transmission/distribution systems. Oku, et al., have reported the serious status of harmonic pollution in Japan [1], [2]. This implies that harmonic damping would be as effective in solving harmonic pollution as harmonic compensation [3]. Hence, electric power utilities have the responsibility for harmonic damping throughout power distribution systems, while individual customers and end users are responsible for harmonic compensation of their own nonlinear loads.

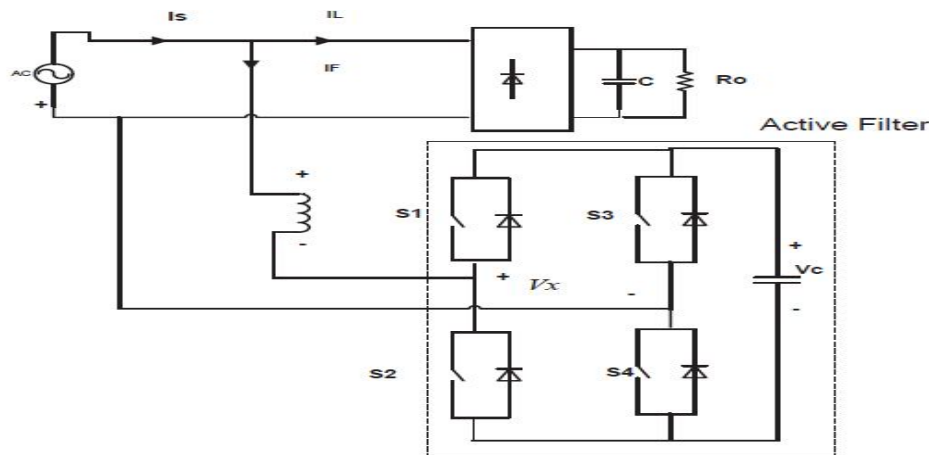

Fig. 1 Shunt Active Filter with Non-linear load

International Journal for Research in Applied Science & Engineering Technology (IJRASET)

The shunt active filter shown in Fig.1 is the most fundamental system configurations. The shunt APF is controlled to draw and inject compensating current, if to the power system and cancel the harmonic currents on the ac side of a general purpose rectifier. Besides that, it has the capability of damping harmonic resonance between an existing passive filter and the supply impedance.

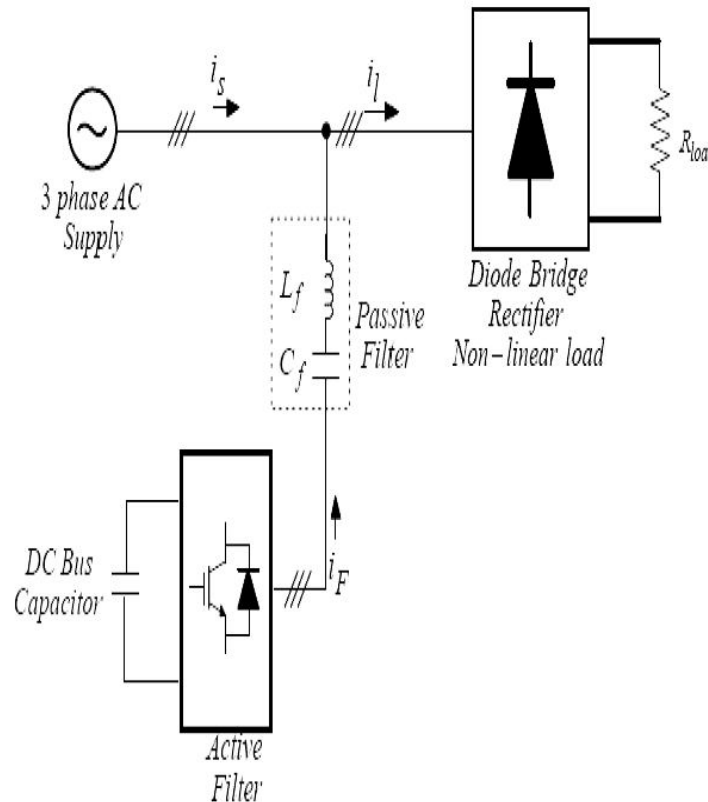

Fig.2 Hybrid active filter

II. CLASSIFICATION OF ACTIVE FILTERS

A. Classification based on objective: Who is Responsible for Installing Active filters? The objective of —who is responsible for installing active filters| classifies them in to the following two groups: A) Active filters of installed by individual consumer on their own premises near one or more identified harmonic producing loads: B) Active filters installed by electrical power utilities in substation and /or on distribution feeders. The main purpose of the active filter installed by individual consumers is to compensation for current harmonics and/or current imbalance of their own harmonic producing loads. On the other hand ,the primary purpose of active filter installed by utilities in the near future is to compensate for voltage harmonics and voltage imbalance ,or to provide —harmonic damping —throughout power distribution system. In addition active filters have the function of harmonic isolation at the utility –consumer point of common coupling in power distribution system. B. Classification by System Configuration Shunt Active Filters and Series Active Filters: fig 2 shows a system a system configuration of a shunt active filter used alone, presents the electrical scheme of a shunt active filter for a three-phase power system with neutral wire, which is able to compensate for both current harmonics and power factor. Furthermore, it allows load balancing, eliminating the current in the neutral wire. The power stage is, basically, a voltage-source inverter with only a single capacitor in the DC side (the active filter does not require any internal power supply), controlled in a way that it acts like a current-source. From the measured values of the phase voltages (v_a, v_b, v_c) and load currents (i_a, i_b, i_c), the controller calculates the reference currents ($i_{ca}^*, i_{cb}^*, i_{cc}^*, i_{cn}^*$) used by the inverter to produce the compensation currents ($i_{ca}, i_{cb}, i_{cc}, i_{cn}$). This solution requires 6 current sensors and 4 voltage sensors, and the inverter has 4 legs (8 power semiconductor switches).For balanced loads without 3rd order current harmonics (three-phase motors, three-phase adjustable speed drives, three-phase controlled or non-controlled rectifiers, etc) there is no need to compensate for the current in neutral wire. These allow the use of a simpler inverter (with only three legs) and only 4 current sensors. It also eases the controller calculations.

International Journal for Research in Applied Science & Engineering Technology (IJRASET)

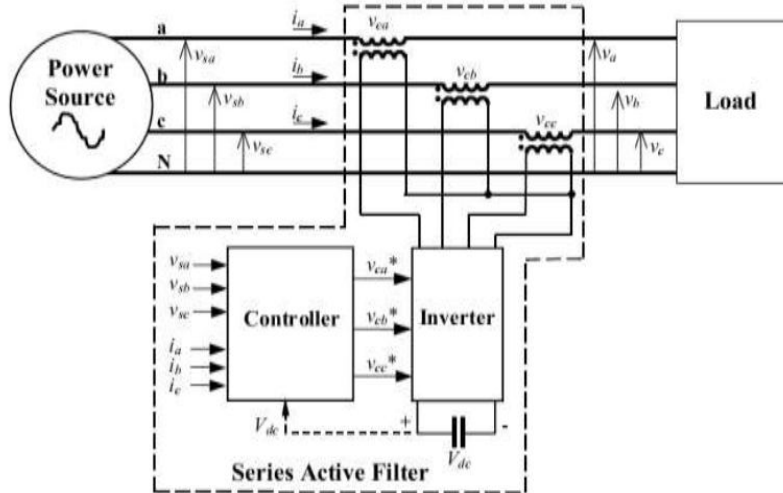

Fig3. Shunt Active Filter in 3 phase system

III. SIMULATION RESULTS

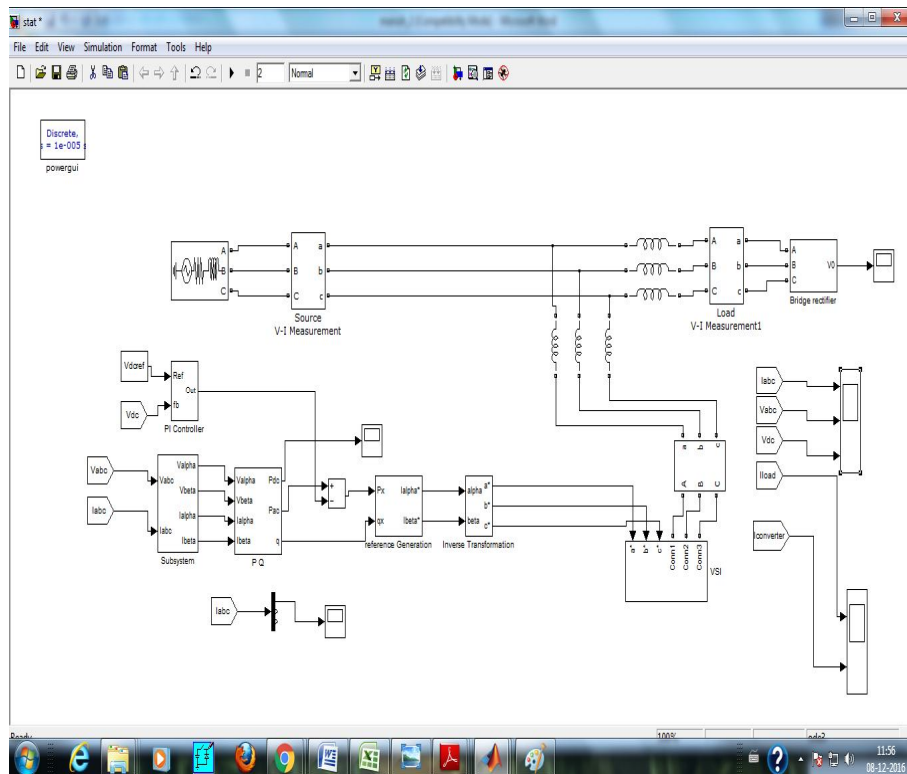

Fig.4 Simulation of shunt active filter

IV. RESULTS

A MATLAB simulation is done to implement shunt active filter using synchronous d-q theory. A sinusoidal three phase supply is assumed and details are given in Table 1. A 3 Φ diode Rectifier with resistor is used as a non-linear load. Fig 4 shows the simple power system model of diode bridge rectifier model using MATLAB. THD is reduced to 1.94%

International Journal for Research in Applied Science & Engineering Technology (IJRASET)

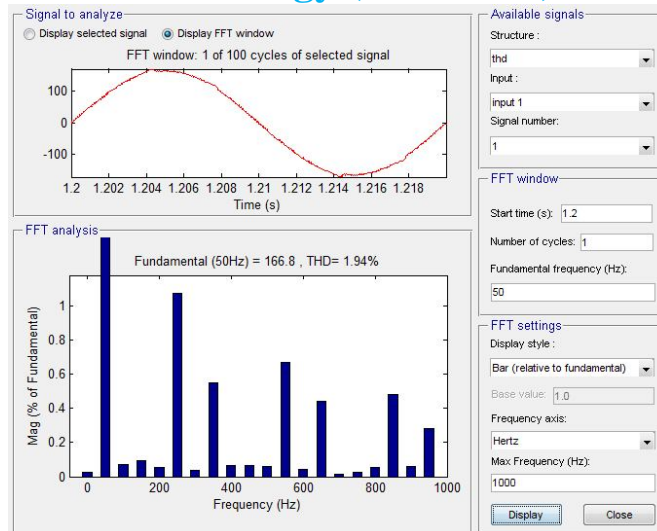

Fig.5THD

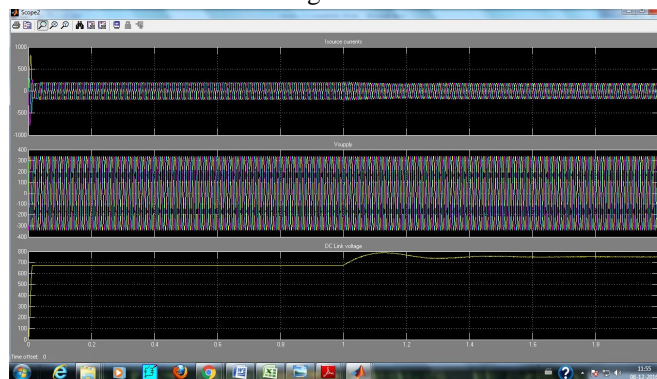

Fig.6 DCLink voltage

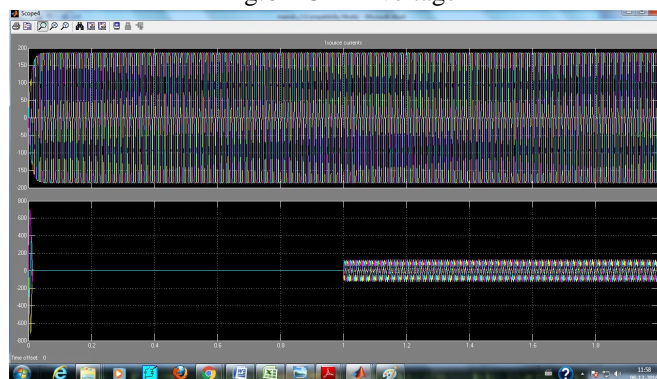

Fig.7 Source voltage waveform

V. CONCLUSION

In this method, a new APF control scheme has been proposed to improve the performance of APF under non-ideal mains voltage conditions. The computer simulations in MATLAB has to verify the effectiveness of the proposed control scheme. Active power filters, based on the proposed theory, give satisfactory operation even when the system phase voltages are unsymmetrical and distorted, because no distortion appears in the line currents. In non-ideal mains voltage condition, the source currents by the instantaneous power (p-q) theory are distorted, but the source currents by the proposed method have no distortion. The increased performance of the APF under different non-sinusoidal mains voltage conditions is extensively demonstrated. The APF is found effective to meet IEEE 519 standard recommendations on harmonics levels in all of the non-ideal voltage conditions. The

International Journal for Research in Applied Science & Engineering Technology (IJRASET)

performance of the proposed algorithm is therefore superior to that of conventional three-phase APF control algorithm. Its control circuit is also simpler than those of published non-ideal mains voltage algorithms. The unsymmetrical distorted voltage system is the most severe condition. However, good results can be obtained by the proposed theory.

REFERENCES

- [1] Emilio F. Couto, Julio S. Martins, Joao L. Afonso, —Simulation Result of a Shunt Active filter with control based on p-q Theory., ICREPQ International Conference on renewable energies and power quality Vigo, Espanha, 9-12 de abril de 2003, paper 394, ISBN: 846076768x
- [2] Emilio F. Couto, Julio S. Martins, Joao L. Afonso, —Shunt active filter for power quality improvement. international conference UIE 2000-Electricity for sustainable Urban Development Lisboa, Portugal 1-4 nov 2000, pp 683-691.
- [3] H. Akagi, New trends in active filters for power conditioning, IEEE Trans. Ind. Appl. 32 (1996) 1312–1322. [4] J. Afonso, et al., Active filters with control based on the p–q theory, IEEE Ind. Electron. Soc. Newsletter 47 (3) (2000) 5–11
- [4] Murat kale, Engin Ozdemir —An adaptive hysteresis band current controller for shunt active power filter. I Electric power system research 73(2005)113-119.
- [5] Murat kale, Engin Ozdemir —Harmonic and reactive power compensation with shunt active power filter under non-ideal mains voltage, I Electric power system research 74(2005) 363-370.
- [6] S. Lotfi and M. Sajedi* Role of a Shunt Active Filter in Power Quality Improvement and Power Factor Correction J. Basic. Appl. Sci. Res., 2(2)1015-1020, 2012 © 2012, TextRoad Publication ISSN 2090-4304 Journal of Basic and Applied.



10.22214/IJRASET



45.98



IMPACT FACTOR:
7.129



IMPACT FACTOR:
7.429



INTERNATIONAL JOURNAL FOR RESEARCH

IN APPLIED SCIENCE & ENGINEERING TECHNOLOGY

Call : 08813907089  (24*7 Support on Whatsapp)