



iJRASET

International Journal For Research in
Applied Science and Engineering Technology



INTERNATIONAL JOURNAL FOR RESEARCH

IN APPLIED SCIENCE & ENGINEERING TECHNOLOGY

Volume: 5 Issue: III Month of publication: March 2017

DOI: <http://doi.org/10.22214/ijraset.2017.3093>

www.ijraset.com

Call:  08813907089

E-mail ID: ijraset@gmail.com

Non-Conventional Power Generation Through Knee

Syed Azam Pasha Quadri¹, R. Suman², Hisham Md. M. Q.³, Imad Md. S.⁴, Md. Wasi⁵
¹Head of Department, ²Assistant Professor, ^{3,4,5}Students, Mechanical Department,
Lords Institute of Engineering & Technology, R . R Dist, Hyderabad, Telangana, India.

Abstract: *The project non-conventional energy generation through knee is a power generating device designed to fit outside the knee for power generation by application of mechanical energy. The purpose and motive of this project is to generate power with conversion of mechanical energy into electrical energy. Non-conventional energy using human metabolism converts the mechanical energy. The spur gears present in the device rotates as the knee joint goes through a walking motion. The knee itself is a starting point for energy generation which is in contact with the spur gears that generates power.*

Keywords: *Spur gears, DC generator, Charging circuit, G Energy.*

I. INTRODUCTION

The power generation which is designed to fit onto the outside of the knee, is circular and consists of two spur gears. The spur gear rotates as the knee joint goes through a walking motion. The knee itself is an ideal starting point for energy generation as it has a large change in angle during walking and does so at significant speeds. A spur gear attached to the joint could therefore generate large amounts of power. Non-conventional energy system is very essential at this time to our nation. Non-conventional energy using foot step is converting mechanical energy into the electrical energy. This project using simple spur gear drive mechanism for power generation. The control mechanism carries the spur gear mechanism, D.C generator, battery and charging circuit. The D.C generator used in this project is Permanent Magnet D.C generator. The generator is coupled to the shaft with the help of spur gear mechanism.

II. METHODOLOGY

A. Working Principle

The complete diagram of the Knee power generation is given below. When knee movement gets inclined in certain small angle which is used to generate the power. The pushing power is converted into electrical energy by proper driving arrangement. The spur gear arrangement is fixed at the inclined movement. The spur gear is connected to shaft of the DC generator. The smaller gear is running same direction for the forward and reverse direction of rotational movement of the larger gear using spur gear mechanism. The fly wheel and gear wheel is also coupled to the smaller gear to the shaft. The gear wheel is coupled to the generator shaft with the help of another gear wheel. The generator is used here, is permanent magnet D.C generator. The generated voltage is 12Volt D.C which is used to charge the battery using charging circuit.



Fig.1.Knee Strap Structure

International Journal for Research in Applied Science & Engineering Technology (IJRASET)

- 1) In this project we are using a DC motor as generator. The linear mechanical movement is converted to angular movement.
- 2) We are also using a flywheel [mechanical device] used as a storage device for rotational energy.
- 3) The DC generator is directly coupled to the flywheel. It generates the voltage that can be stored in a rechargeable mobile for further usage.

III. HARDWARE DESCRIPTION

In this chapter the block diagram of the project and design aspect of independent modules are considered. Block diagram is shown below:

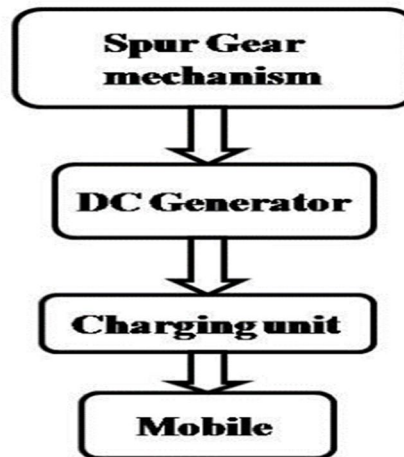

Fig.2. Block Diagram

The block diagram shows 4 major components i.e.

A. Spur Gear Mechanism

The pinion is the smallest gear and the larger gear is called the gear wheel. A rack is a rectangular prism with gear teeth machined along one side- it is in effect a gear wheel with an infinite pitch circle diameter.

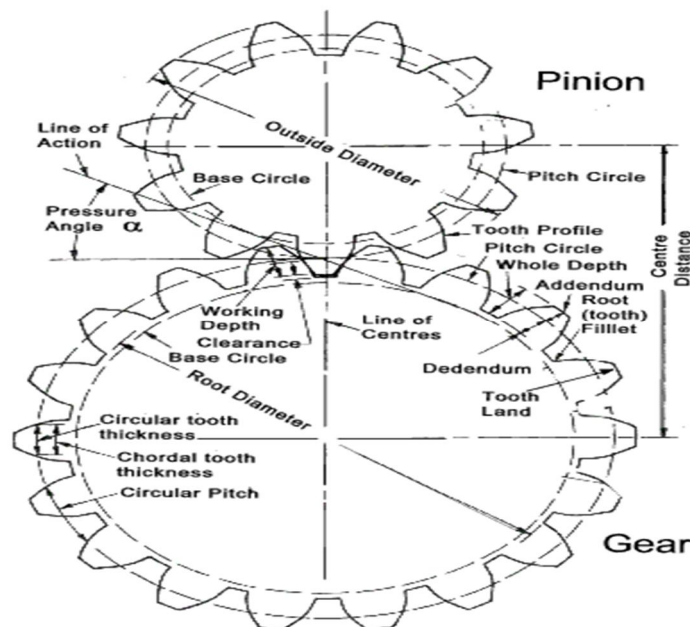

Fig.3. Spur gear design

International Journal for Research in Applied Science & Engineering Technology (IJRASET)

B. DC Generator

An electrical generator is a machine which converts mechanical energy (or power) into electrical energy (or power). Induced EMF is produced in it according to Faraday's law of electromagnetic induction. This EMF causes a current to flow if the conductor circuit is closed.

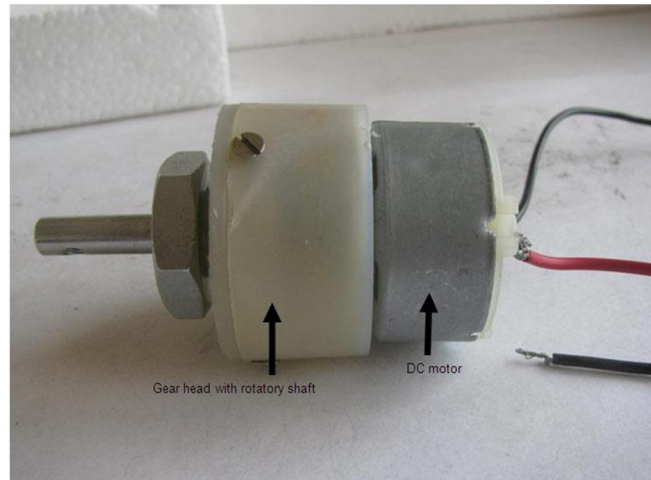

Fig.4. DC Motor

C. Charging Unit

The 18v AC converts to 18V pulsating DC which in turn is converted to smooth DC with the help of the Capacitor. This 18V Smooth DC is converted to 12V DC by the Voltage Regulator 7805. At the output of the regulator, we get some spikes which are removed with the help of another capacitor used. We can get 5V Steady DC at the output terminal which can be indicated if the LED glows.

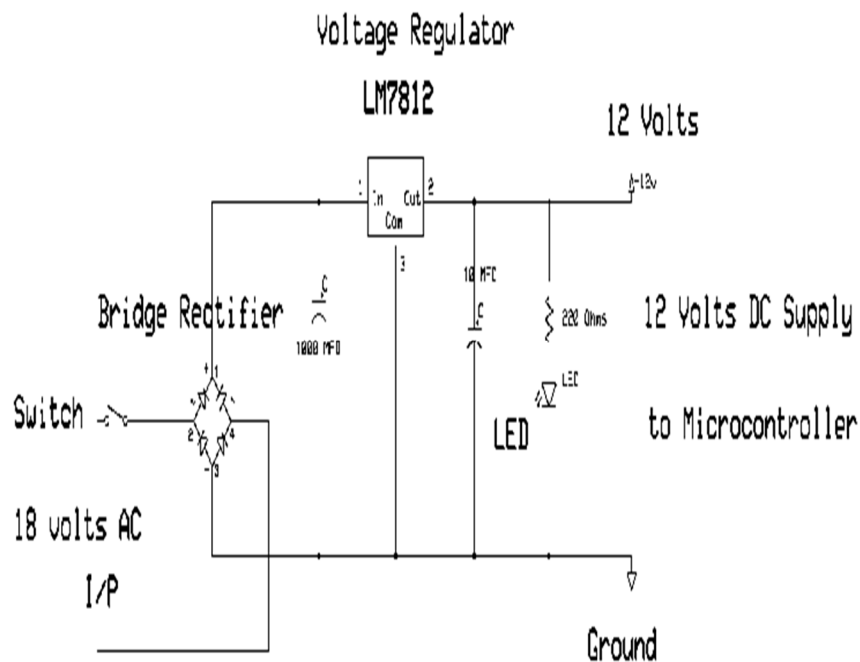

Fig.5. Charging Circuit

International Journal for Research in Applied Science & Engineering Technology (IJRASET)

TABLE I

Material	Notes	Applications
Ferrous metals		
Cast Iron	Low cost, easy to machine with high damping	Large moderate power, commercial gears
Cast Steels	Low cost, reasonable strength	Power gears with medium rating to commercial quality
Plain-Carbon Steels	Good machining, can be heat treated	Power gears with medium rating to commercial/medium quality
Alloy Steels	Heat Treatable to provide highest strength	Highest power requirement. For high precision
Non metals		
Acetal (Delrin)	Wear resistant, low water absorption	Long life , low load bearings to commercial quality
Phenolic laminates	Low cost, low quality, moderate strength	High production, low quality to moderate commercial quality
Nylons	No lubrication, no lubricant, absorbs water	Long life at low loads to commercial quality
PTFE	Low friction and no lubrication	Special low friction gears to commercial quality

IV. CONCLUSION

We have developed a biomechanical energy harvester for generating electricity from walking:

- A. 5V output is obtained while walking which can be used to charge the mobile phone requiring 3.7V in real time.
- B. The device was efficient and the control system was effective at selectively engaging power generation.
- C. Consequently, subjects were able to generate substantial amounts of electrical power with little additional effort over that required to support the device mass.
- D. The amount of available energy at moderate walking speeds is only slightly less than that at the end of swing and it increases strongly with speed.
- E. Thus, in all we conclude that with this process, we can extract the energy from the human feet, convert it into electric energy and use it in real time application of charging the devices.

V. ACKNOWLEDGEMENT

It gives us immense pleasure to present our research paper titled "NON-CONVENTIONAL ENERGY GENERATION THROUGH KNEE". We are thankful to our honorable HOD, Syed Azam Pasha Quadri and Asst. Professor R. Suman, Department of Mechanical engineering, Lords Institute of Engineering & Technology, Hyderabad, for their support and encouragement.

International Journal for Research in Applied Science & Engineering Technology (IJRASET)

REFERENCES

- [1] Almuahed, S., Gouriou, M., Hamitouche, C., Stindel, E. and Roux, C. (2011) "The use of piezoceramics as electrical energy harvesters within instrumented knee implant during walking", *IEEE/ASME Transactions on Mechatronics*, Vol.16, No. 5, pp.799-807.
- [2] Austin, M.S., Sharkey, P.F., Hozack, W.J. and Rothman, R.H. (2004) "Knee failure mechanisms after total knee arthroplasty", *Techniques in Knee Surgery*, Vol. 3, No. 1, pp.55-59
- [3] D'Lima, D.D., Patil, S., Steklov, N., Chien, S. and Colwell, C.W. Jr. (2007) "In vivo knee moments and shear after total knee arthroplasty", *Journal of Biomechanics* Vol. 40, Suppl. 1, pp.S11-S17.
- [4] Jevsevar, D.S., Riley, P.O., Hodge, W.A. and Krebs, D.E. (1993) "Knee kinematics and kinetics during locomotor activities of daily living in subjects with knee arthroplasty and in healthy control subjects", *Physical Therapy*, Vol. 73, No.4, pp.229-239.
- [5] Luciano, V., Sardini, E., Serpelloni, M. and Baronio, G. (2012) "Analysis of an electromechanical generator implanted in a human total knee prosthesis", *Proceedings of the IEEE Sensors, Applications Symposium*, Vol. 6, No.3, pp.166-170.
- [6] McClelland, J.A., Webster, K.E. and Feller, J.A. (2009) "Variability of walking and other daily activities in patients with total knee replacement", *Gait & Posture*, Vol. 30, No. 3, pp.288-295.
- [7] McClelland, J.A., Webster, K.E., Feller, J.A. and Menz, H.B. (2011) "Knee kinematics during walking at different speeds in people who have undergone total knee replacement", *The Knee*, Vol. 18, No. 3, pp.151-155.
- [8] Mitcheson, P.D., Yeatman, E.M., Rao, G.K., Holmes, A.S. & Green, "wireless electronic devices", *Proceedings of the IEEE*, Vol. 96, No. 9, pp.1457-1486.
- [9] Rocha, J.G, Gonçalves L. M, Rocha .P. F, Silva. M. P., And Lanceros-Méndez. S. (2010) "Energy Harvesting From Piezoelectric Materials Fully Integrated In Footwear", *IEEE Transactions On Industrial Electronics*, Vol. 57, No. 3, March 2010.
- [10] Amirtharajah, R., and Chandrakasan, A. P., 1998, "Self Powered Signal Processing Using Vibration Based Power Generation," *IEEE Journal of Solid-State Circuits*, Vol. 33, No. 5, 687-695.
- [11] Clark, R. L., Saunders, W. R., and Gibbs, G. P., 1998, *Adaptive Structures: Dynamics and Control*, Wiley, New York.
- [12] Crawley, E., and Anderson, E., 1990, "Detailed Models of Piezoceramic Actuation of Beams," *Journal of Intelligent Materials and Structures*, Vol.1, No. 1, 4-25.
- [13] Elvin, N. G., Elvin, A. A., and Spector, M., 2001, "A Self-Powered Mechanical Strain Energy Sensor", *Smart Materials and Structures*, Vol. 10, 293-299.
- [14] Goldfarb, M., and Jones, L. D., 1999, "On the Efficiency of Electric Power Generation with Piezoelectric Ceramic," *ASME Journal of Dynamic Systems, Measurement, and Control*, Vol.121, 566- 571.



10.22214/IJRASET



45.98



IMPACT FACTOR:
7.129



IMPACT FACTOR:
7.429



INTERNATIONAL JOURNAL FOR RESEARCH

IN APPLIED SCIENCE & ENGINEERING TECHNOLOGY

Call : 08813907089  (24*7 Support on Whatsapp)