



iJRASET

International Journal For Research in
Applied Science and Engineering Technology



INTERNATIONAL JOURNAL FOR RESEARCH

IN APPLIED SCIENCE & ENGINEERING TECHNOLOGY

Volume: 2017 Issue: Month of publication: March 31, 2017

DOI:

www.ijraset.com

Call:  08813907089

E-mail ID: ijraset@gmail.com

Pollution Control Using Aqua Silencer in Automobiles

S.Raffek¹, S.Rohit², R.Mathivanan³, M.Muthaiah⁴

¹Assistant Professor, Department of Mechanical Engineering,

²Arjun College of Technology, Coimbatore – 641 120

³U.G. Scholars, Department of Mechanical,

⁴Arjun College of Technology, Coimbatore – 641 120

Abstract: Aqua Silencer is mainly dealing with control of emission and noise in automobile exhaust. By using activated charcoal, perforated tube and outer shell it is constructed. An aqua silencer is fitted to the exhaust pipe of engine. The activated charcoal filters the harmful sulphur and nitrous content produced from the engine. Sound produced under water is less hearable than it produced in atmosphere. This mainly because of small sprockets in water molecules, which lowers its amplitude thus, lowers the sound level. Because of this property water is used in this silencer and hence its name AQUA SILENCER. It is tested in single cylinder 4- stroke diesel engine the noise and smoke level is considerable less than the conventional silencer. The main pollutants contribute by automobiles are CO, UBHC, Nox and Lead etc., other sources such as electric power generating stations, industrial and domestic fuel consumption, refuse burning, industrial processing. So it is imperative that serious attempts should be made to conserve earth's environment from degradation. An aqua silencer is an attempt in this direction; it is mainly dealing with control of emission and noise.

keywords: Aqua Silencer, activated charcoal, perforated tube, outer shell, sulphur, oxides of Nitrogen, noise.

I. INTRODUCTION

Diesel engines are playing a vital role in Road and sea transport, Agriculture, mining and many other industries. Considering the available fuel resources and the present technological development, Diesel fuel is evidently indispensable. In general, the consumption of fuel is an index for finding out the economic strength of any country. In spite, we cannot ignore the harmful effects of the large mass of the burnt gases, which erodes the purity of our environment every day. An aqua silencer is used to control the noise and emission in IC engines.

The reason why we go for aqua silencer is, in today life the air pollution causes physical ill effects to the human beings and also the environment. The main contribution of the air pollution is automobiles releasing the gases like carbon dioxide, unburned hydrocarbons etc. In order to avoid this type of gases we can use aqua silencer. It is fitted to the exhaust pipe of the engine; Sound produced under water is less hearable than it produced in atmosphere. This mainly because of small sprockets in water molecules, which lowers its amplitude thus, lowers the sound level. The emission can be controlled by using the activated charcoal layer and Lime water. Activated charcoal layer is highly porous and posse's extra free valences so it has high absorption capacity along with this lime water chemically reacts with the exhaust gases from the engine and release much less pollution to the environment. The noise and smoke level is considerable less than the conventional silencer, no need of catalytic converter and easy to install.

II. COMPONENTS AND EXPLANATION

A. Perforated Tube

The perforated tube consists of number of holes of different diameters. It is used to convert high mass bubbles to low mass bubbles. The charcoal layer is pasted over the perforated tube.

B. Charcoal Layer

The charcoal layer has more absorbing capacity because it has more surface area. This charcoal is called as ACTIVATED CHARCOAL. It is produced by heating the charcoal above 1500 °c for several hours in a burner. Its surface area gets increased.

C. Outer Shell

The whole setup was kept inside the outer shell. It is made up of iron or steel. The water inlet, outlet and exhaust tube was provided in the shell itself. 2.4 U Bend

The U Bend is provided instead of a non return valve which is a mechanical device , which normally allows fluid (liquid or gas) to flow through it in only one direction. The Aqua silencer was filled with water and it is directly connected to the exhaust pipe of the engine. There is a chance for the water to get enter into the engine cylinder. To avoid this, U bend is used.

D. Flange

A flange joint is a connection of pipes, where the connecting pieces have flanges by which the parts are bolted together. Here flange is used to connect the silencer to the engine.

III. CONSTRUCTION

Basically an aqua silencer consists of a perforated tube which is installed at the end of the exhaust pipe. The perforated tube may have holes of different diameters. The very purpose of providing different diameter hole is to break up gas mass to form smaller gas bubbles the perforated tube of different diameters. Generally 4 sets of holes are drilled on the perforated tube. The other end of the perforated tube is closed by plug. Perforated tube contains lime water inside it which chemically reacts with exhaust gas from the engine.

Around the circumference of the perforated tube a layer of activated charcoal is provided and further a metallic mesh covers it. The whole unit is then placed in a water container. A small opening is provided at the Top of the container to remove the exhaust gases. A U bend is provided at the end of perforated tube which functions as a non return valve which prevents the back flow of exhaust gas and lime water back to the engine.

A. Design Of Aqua Silencer

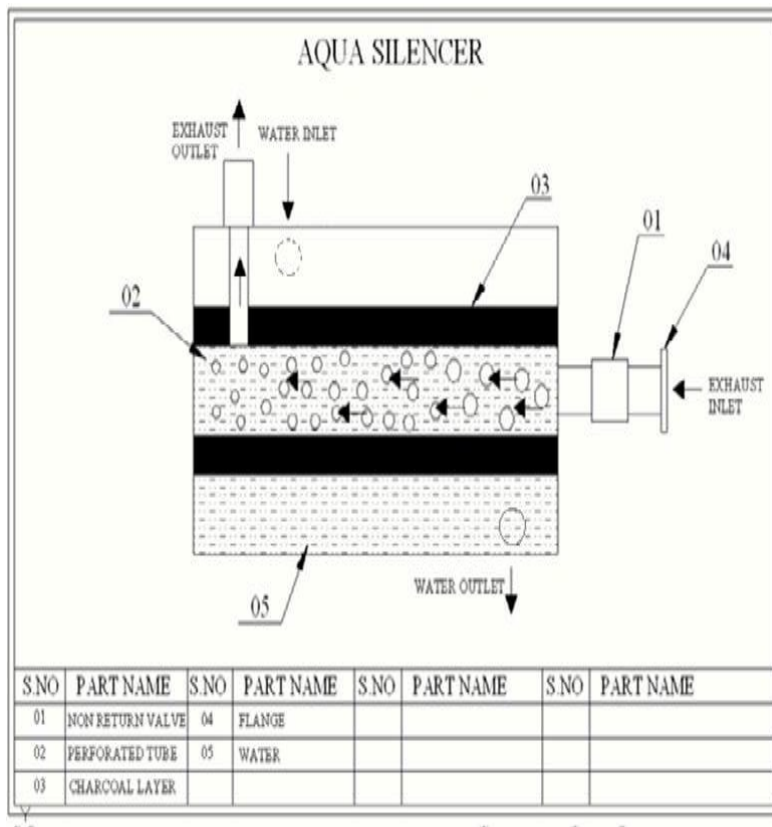

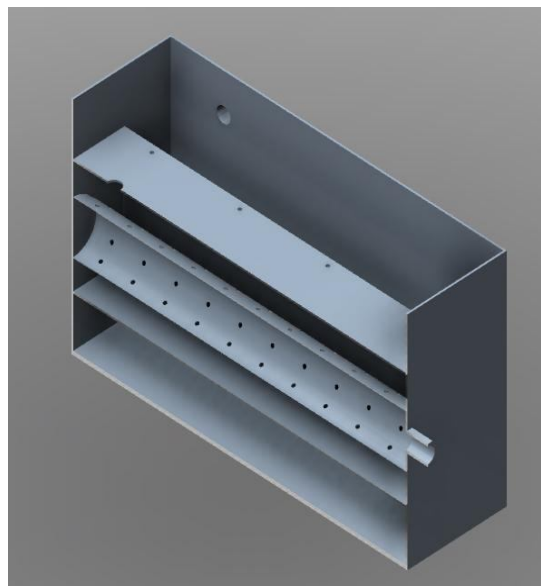
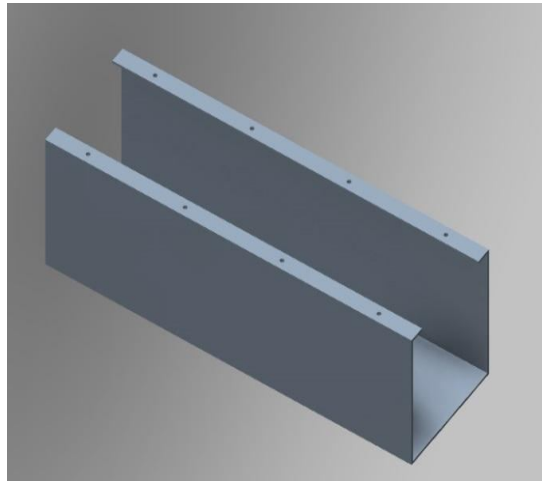
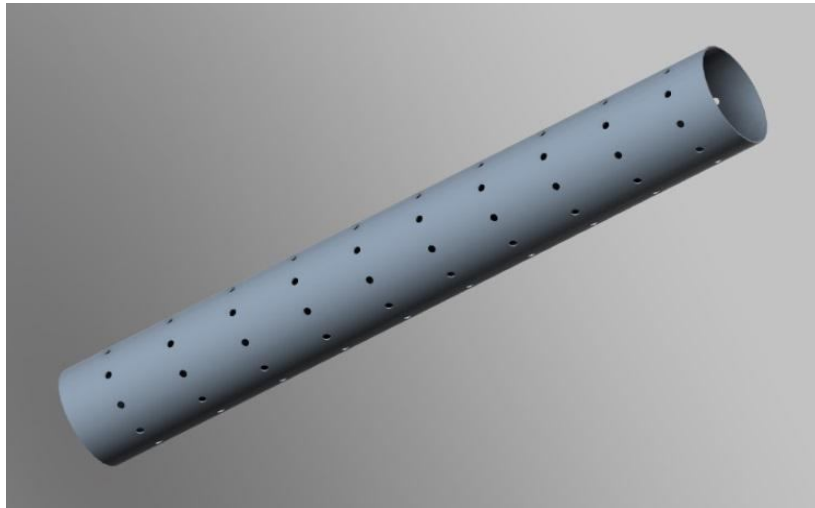

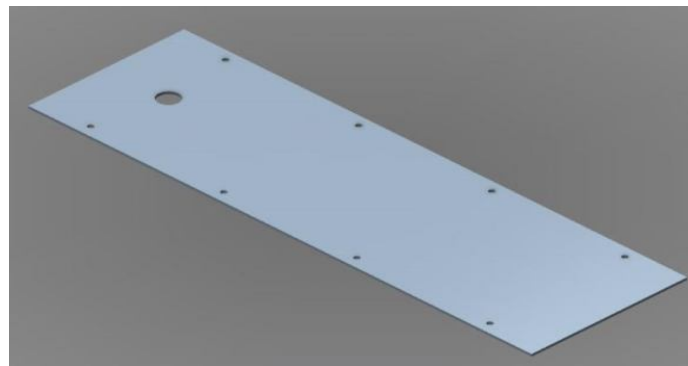
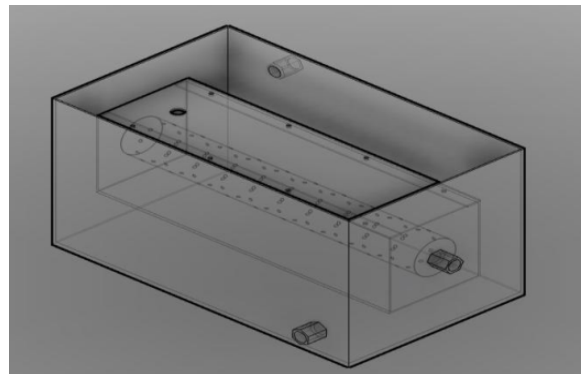
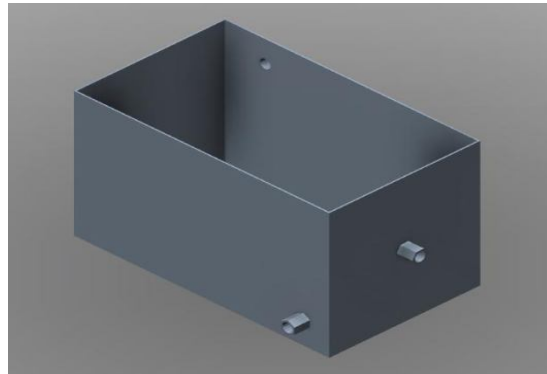

IV. WORKING

As the exhaust gases enter in to the aqua silencer, the perforated tube converts high mass bubbles in to low mass bubbles after that they come in to contact with lime water they chemically react with it and pass through the pass through charcoal layer which again purify the gases. It is highly porous and posses extra free valences so it has high absorption capacity.

Since the charcoal layer is covered with outer shell which is filled with water. Sound produced under water is less hereable than it produced in atmosphere. This is mainly because of small sprockets in water molecules, which lowers its amplitude thus, lowers the sound level hence aqua silencer reduces noise and pollution.

V. EFFECTS OF DISSOLVED GASES ON LIME WATER

The lime water is a good absorbing medium. In aqua silencer the gases are made to be dissolved in lime water. When these gases dissolved in water they form acids, carbonates, bicarbonates etc,

A. Action Of Dissolved So₂

When SO_x is mixed in water, it form SO₂, SO₃, SO₄, H₂SO₄ i.e. sulfur Acid (H₂SO₃), it forms Hydrogen Sulphide which causes

fol rotten egg smell, acidify and corrosion of metals.

B. Action Of Dissolved Co₂

The dissolved carbon dioxide forms bicarbonate at lower PH and Carbonates at higher PH. This levels 40-400 mg/liter.. The carbon dioxide mixes with water to form Carbonic acid. It is corrosive to metals and causes green house effect.

C. Effect Of Dissolved No_x

The NO_x in exhaust gas under goes Oxidation to form ammonia, Nitrate, Nitrite, Nitric acid. This synthesis of protein and amino acids is effected by Nitrogen. Nitrate usually occurs in trace quantities in exhaust gas.

D. Absorption Process

Activated charcoal is available in granular or powdered form. As it is highly porous and Possess free valences. So it possesses high absorption capacity. Activated carbon is more widely used for the removal of taste and odorous from the public water supplies because it has excellent properties of attracting gases, finely divided solid particles and phenol type impurities, The activated carbon, usually in the powdered form is added to the water either before or after the coagulation with sedimentation. But it is always added before filtration. Feeding devices are similar to those used in feeding the coagulants.

VI. MERITS

- A. No vibration when the engine is running.
- B. Start the engine easy.
- C. Control emission and noise in greater level.
- D. Carbon is precipitated.

VII. RESULTS AND DISCUSSION

First we determine the amount of exhaust gas like hydrocarbons, nitrogen etc which is present in the single cylinder diesel engine without connecting Zero emission silencer and then aqua silencer (without lime water)is connected on the exhaust and determine the amount of exhaust gas by smoke analyser. At last the silencer (with lime water) which is connected to exhaust pipe and readings are taken. The results which are obtained from the project analysis is given below in the tables. Smoke analyser tests were carried out for analyzing the performance of the silencer.

VIII. TEST USING SIMPLE SILENCE

The smoke from a single cylinder four stroke diesel engine is made to pass through the an aqua silencer by connecting it to the exhaust of the engine.

IX. TEST USING SILENCER WITH ACTIVATED CHARCOAL

Activated charcoal is used in the silencer, because of its high absorption capability. It can absorb some portions of the toxic gases present in the exhaust.

During this test, it is found that the amount of hydrocarbons and nitrogen dioxide are reduced as compared to the previous test. This is because of the reason that the charcoal embedded inside the silencer has absorbed certain amount of the gas. The changes in the amount of other gases are negligible.

X. TEST USING LIME WATER

In this test lime water is filled inside the silencer. This test is found to be more efficient. The amount of hydrocarbon has increased than that of the previous test. This is due to the reason that, while applying lime water the temperature will be decreased inside the silencer. High temperature is needed for the hydrocarbon to burn completely and this results in the incomplete combustion of the hydrocarbon.

But it is found that there is a considerable reduction in the amount of nitrogen dioxide. As nitrogen dioxide is more toxic than hydrocarbons, this test is considered as more efficient.

XI. CONCLUSION

The aqua silencer is more effective in the reduction of emission gases from the engine exhaust using perforated tube, lime water and charcoal by using perforated tube the back pressure will remain constant and the sound level is reduced. By using perforated tube the fuel consumption remains same as conventional system by using water as a medium the sound can be lowered and also by using activated charcoal in water we can control the exhaust emission to a greater level. The water contamination is found to be negligible in aqua silencer. It is smokeless and pollution free emission equivalent to the conventional to the silencer

XII. SCOPE FOR FUTURE RESEARCH

There has been an increasing concern in recent years over the increasing of transportation and discharge of industrial waste waters into environment. The engine emission contains air pollutants and other species. Almost all pollutants are toxic in nature. Some of the examples are CO, CO₂, NO_x, and Hydrocarbon. Among the air pollutants, all are most effective pollutants. Hence, the removal of pollutants was selected for the present study. Several expensive techniques are available in developed countries. But in developing countries like India is not applicable since adsorption technique is less expensive and economically feasible, it has been selected for the present study using some cheap cost chemicals as an effective adsorbent. Therefore the objective of the present work was to test the ability of some chemicals in removing air pollutants from engine emission. In future researches are going on to develop an aqua silencer which can be fitted in to automobiles without effecting its aerodynamics properties and efficiency.

REFERENCES

- [1] Mankhiar Ajay B, Sindhu L S, G Sasikala, (March 2014) "An Advancement to Reduce Pollution Effectively by Using TI Nano tubes in Aqua Silencer", International Journal of Engineering Sciences and Research Technology .
- [2] Rawale Sudrshan S & Patil S Nehal S, (September 2013) "Use of aqueous Ammonia in Silencer for removal of CO₂, SO₂ and NO_x from exhaust gases of IC Engines", International Journal of Engineering Science and Innovative Technology, Vol.2, Issue 5.
- [3] Swastik R, Gajjar, (June 2014) "Design and Development of Aqua Silencer for Two Stroke Petrol Engine", International Journal for Innovative Research in Science and Technology, Vol.1, Issue 1.
- [4] Balashanmugam P, Balasubramanian, (January 2015) [5] "Developments of Emission and Noise Control Device", International Journal of Modern Trends in Engineering and Research, Vol.02, Issue 01
- [5] Amruthraj M, Nataraj J.R. & Sushmit Poojary, (October 2012) "Emission Control in IC Engines", International Journal of Engineering Research and Development, Vol .4, Issue 4.
- [6] K. Kannan & M. Udayakumar, (October 2009) "NO_x and HC Emission Control Using Water Emulsified Diesel in Single Cylinder Diesel Engine", ARPN Journal of Engineering and Applied Sciences, Vol.4, No 8 .
- [7] Guromoorthy S. Hebbar & Anantha Krishna Bhat, (July-Aug. 2012) "Diesel Emission Control by Hot EGR and Ethanol Fumigation; an Experimental Investigation", International Journal of Modern Engineering Research, Vol.2, Issue.4, pp-1486-1491.
- [8] Prabavathi Nagarajan & Priscilla Prabavathi, (November 1999) "A Study of removal of Pb (II) by adsorption technique using carbonized tamarind seed", Indian Environment. Prot. 25(5): 433 □ 435.



10.22214/IJRASET



45.98



IMPACT FACTOR:
7.129



IMPACT FACTOR:
7.429



INTERNATIONAL JOURNAL FOR RESEARCH

IN APPLIED SCIENCE & ENGINEERING TECHNOLOGY

Call : 08813907089  (24*7 Support on Whatsapp)