



IJRASET

International Journal For Research in
Applied Science and Engineering Technology



INTERNATIONAL JOURNAL FOR RESEARCH

IN APPLIED SCIENCE & ENGINEERING TECHNOLOGY

Volume: 5 Issue: VI Month of publication: June 2017

DOI:

www.ijraset.com

Call:  08813907089

E-mail ID: ijraset@gmail.com

Power Quality Improvement By Svc Using PIC18F4

Mr. Vijay S. Gadakh¹ Dr. Dinesh M. Chandwadkar²

¹Department of Electronics and Telecommunication K K Wagh College of engineering Nashik [MH], India

²Head, Department of Electronics and Telecommunication K.K.Wagh College of engineering Nashik [MH], India

Abstract- Power quality improvement for non linear loads is the point of interest for researchers in recent years. Power factor plays an effective role in efficiency of electrical system. In power system the voltage level at different system changes with the change in load. The voltage level at the load must be maintained within required range irrespective of the type & magnitude of the load. For maintaining voltage fixed within limits, it is necessary to maintain the balance of reactive power in the system as reactive power is related with voltage directly. i.e reactive power generation and absorption must be equal. Any mismatch occurs in the reactive power balance affects the bus voltage magnitude.

A static VAR compensator include capacitor bank in different binary sequential steps in conjunction with a thyristor controlled reactor of minimum step size is used in the investigative work. The work related with the performance evaluation through analytical studies and practical implementation on an existing system consisting of a distribution transformer of 1 PH phase 50 Hz, 1KV/230V capacity. The switching characteristics achieved are transient free, practically no need to provide inrush current limiting reactors, TCR size minimum providing minimum percentages of nontriplen harmonics, facilitates stepless variation of reactive power depending on load requirement , thus maintain power factor near always unity .

Keywords-Power Factor Improvement; Reactive Power Compensation

I. INTRODUCTION

The demand and the dependency of human being increasing day by day, which causes the increase in demand of electrical power. Most of the loads connected to the electrical system is inductive load which causes the lagging power factor, it makes the system less efficient. For the improvement of efficiency of the system, power factor quality is one of the basic requirements . It is in literature and through public discussions at different levels that a substantial power loss is taking place due to inadequate reactive power compensation facilities and their improper control. The expansion of rural power distribution systems with new connections and catering to agricultural sector in wide spread remote areas, giving rise to more inductive loads resulting in very low power factors. Thus there exists a great necessity to closely match reactive power with the load so as to improve power factor, boost the voltage and reduce the losses. In this system, a more reliable, technically sound, fast acting and low cost scheme is presented by arranging the thyristor switched capacitor units in binary sequential steps. This enables the reactive power variation with the least possible resolution. In addition a thyristor controlled reactor of the lowest step size is operated in conjunction with capacitor bank, so as to achieve continuously variable reactive power. The systematic study has been planned and the work is focused by keeping in view of following objectives: The following expected outcomes are achieved by using microcontroller control signals to Static VAR Compensator (SVC) which fulfill the requirement of reactive power for a 1 PH phase, 50 Hz

- To maintaining the power factor at unity.
- To maintain minimum feeder current
- To improve the distribution feeder efficiency.
- To improve the voltage at load end.
- To relief in maximum demand and effective utilization of -transformer capacity.
- To save the monthly bill on poor power factor, and results in maximum demand charges.
- To conserve the energy.

International Journal for Research in Applied Science & Engineering Technology (IJRASET)

II. SYSTEM HARDWARE

A. SYSTEM MODEL

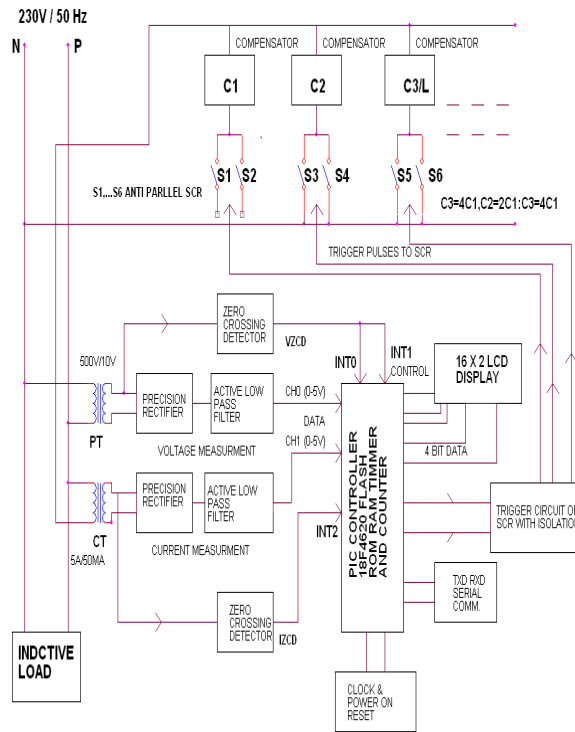

Fig.1 Block Diagram

A. Basics Components of system

- 1) Thyristor/ Contactor Switched Capacitor (TSC/CSC)
- 2) ZCD V and ZCD I for phase shift measurement.
- 3) Current Transformer (CT) and potential Transformer (PT).
- 4) Signal Conditioning Unit.
- 5) PIC controller interface.
- 6) Isolation and firing circuit of SCR.

B. Power Factor

the ratio of active or true power to apparent power is called as Power factor. the power factor is one or unity, When the load is resistive only i.e. the voltage and the current are in phase. Thus, for resistive loads only, both powers are the same. load stores energy, When the load is reactive, releasing it during a various part of the cycle. This shifts the current waveform so that it is out of phase w.r.t. the voltage waveform. Reactive loads may be inductive, capacitive, or non-linear. When the load is inductive, the inductance tends to oppose the flow of current, storing energy then releasing it later in the cycle. The current lags behind the voltage. the current leads the voltage When the load is capacitive, the opposite occurs.

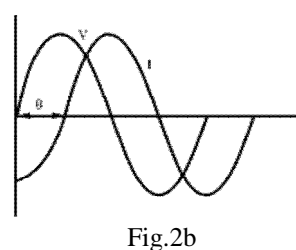
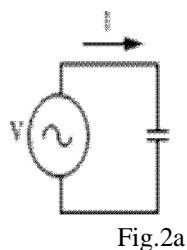

Power Factor for a linear load as shown in Fig. 2a is defined as: $pf = VA \cos \Theta$

International Journal for Research in Applied Science & Engineering Technology (IJRASET)

where, pf = power factor
 V = RMS of AC line voltage
 A = RMS of AC line current I
 Θ = phase angle

C. Phase Shift Measurement

- 1) **Potential Transformer & Current Transformer** : the consumed power by load is sensed by this input stage of the system. Since the amplitude of current and voltage which can process these high level signals is difficult. Therefore, these signals are converted into equivalent 0-5 A current is down to 0-50 mA current and small level signals 0-230 V range is down to 0-6V by voltage transformer.
- 2) **Signal Conditioning Block**: This block consists of precision rectifier. The line provided by electricity board carries ac signals of 50 Hz. After dropping these signals to low levels the actual processing can be accomplished by transforming this ac signal to an equivalent dc signals. General Purpose Op-amp is used along with the diodes, resistors and capacitors. A precision rectifier & active filter is very accurate in this respect. The dc signal is then applied to the inbuilt ADC of PIC controller. AN0 is used for PT and AN1 is used for CT.
- 3.) **Zero Crossing Detectors (ZCD)** ZCD block will convert sine wave signal into square wave signal using comparator. Diode will act as clamper which convert bipolar signal to unipolar. Both the square wave signals for voltage & current will be given to INT0 & INT1 of PIC controller. When INT0 interrupt will occur then internal timer will start and it will stop at INT1 interrupt. Time measurement by timer will give the respective phase shift in terms of Θ .

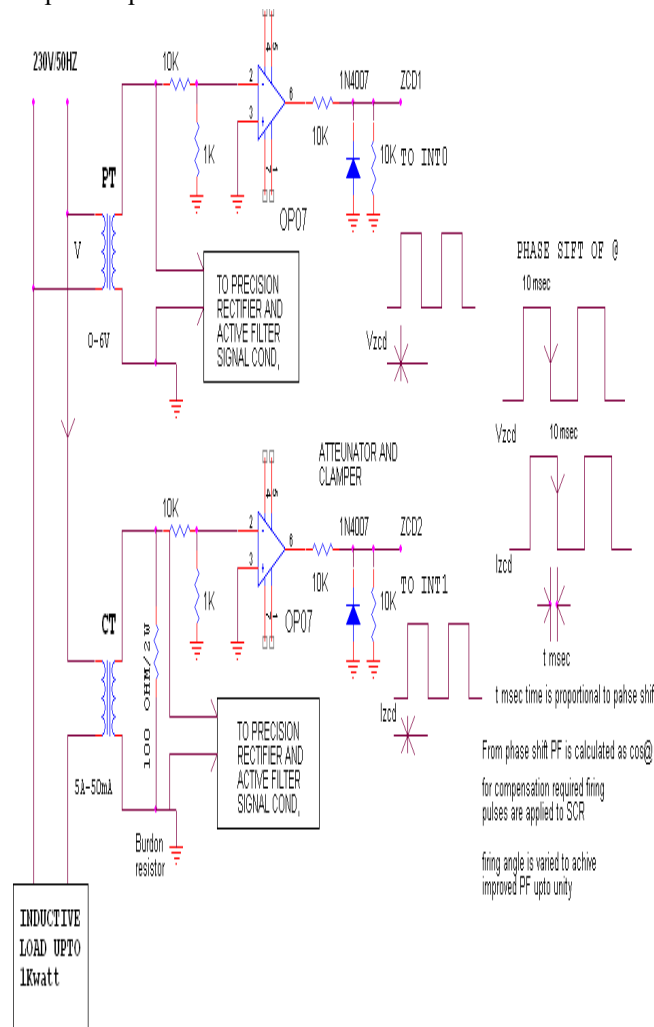

Fig 3.ZCD block for phase shift measurement

International Journal for Research in Applied Science & Engineering Technology (IJRASET)

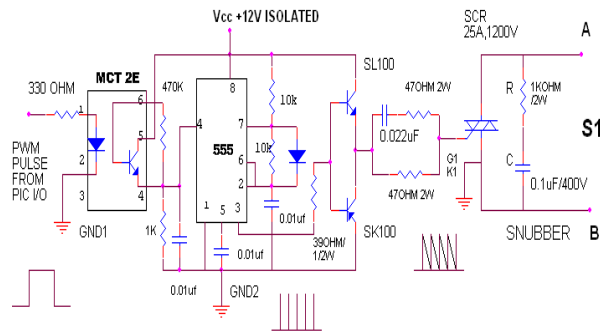

Fig6.Firing circuit

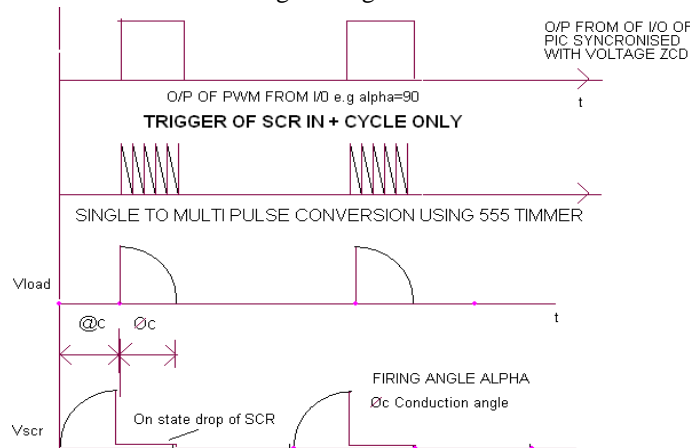

Fig7.Trigger for SCR

according to the required, Capacitor bank will be selected for pf improvement. In order to achieve pf close to unity respective bank firing angle is varied. It provides the VAR compensation in order to improve the pf.

III. ALGORITHM

- A. Observe voltage current and frequency for connected load resistive or reactive.
- B. Observe phase shift of I and V from ZCD nature using timer and interrupt of PIC from phase shift calculate PF.
- C. Observe active and reactive power on LCD using PF without compensation
- D. For compensation ,add equal and opposite reactance in parallel with load.\
- E. control firing angle of capacitor (Anti parallel SCR) we can compensate pf upto unity.
- F. as per design need Capacitor may having value 2,3,4,....
- G. After compensation,observe PF which will be improved.
- H. From required pf & actual measured pf error calculation is done in software. To compensate pf upto unity Firing angle is calculated. Control action which is implemented will be proportional.

IV. SOFTWARE DESIGN

All programming can be done in C language. It makes the program development cycle short, enables use of the modular programming approach.Easily available modules in C compilers for embedded system & library codes that can directly port into the system programmer codes. for compiling program MPLAB software is used.

V. CONCLUSION

Power factor improvement is most desirable for an efficient electrical power system. SVC is one of the best, cost effective and promising solution available for reactive power compensation and improvement of power factor. CT, PT with signal conditioning blocks and ZCD gives very accurate result when observed on DSO.All parameters like Voltage, current, frequency, phase shift, active power and reactive power with compensation and without compensation are calculated and displayed on LCD display. System gives valuable performance for power factor improvement.

International Journal for Research in Applied Science & Engineering Technology (IJRASET)

REFERENCES

- [1] M. N. Nwohu, "Voltage Stability Improvement using Static Var Compensator in Power Systems," Leonardo Journal of Sciences; Issn 1583-0233, issue 14, pp. 167-172, January-June, 2009
- [2] Cha E., Ambriz-Perez H., Fuerte-Esquivel, Advanced SVC Models for Newton-Raphson Load Flow and Newton Optimal Power Flow Studies, IEEE Transactions on Power Systems, 15(1), p.129-136, 2011.
- [3] Hris Fitzer, Mike Barnes and Peter Green, "Voltage Sag Detection Technique for a Dynamic Voltage Restorer," IEEE Trans. Industry Applications, Vol. 40, No. 1, Jan/Feb. 2012, pp. 203-212.
- [4] G.F. Reed, M. Takeda, I. Iyoda, "Improved power quality solutions using advanced solid-state switching and static compensation technologies," IEEE Power Engineering Society 2012 Winter Meeting, New York, USA, vol. 2, pp. 1132-1137.
- [5] Chris Fitzer, Mike Barnes and Peter Green, "Voltage Sag Detection Technique for a Dynamic Voltage Restorer," IEEE Trans. Industry Applications, Vol. 40, No. 1, Jan/Feb. 2004, pp. 203-212.
- [6] J. Zhang, J. Y. Wen, S. J. Cheng, and J. Ma, "A novel SVC allocation method for power system voltage stability enhancement by normal forms of diffeomorphism," IEEE Trans. Power Syst., vol. 22, no. 4, pp. 1194–1203, Nov. 2012.
- [7] N. G. Hingorani and L. Gyugi, "Understanding FACTS–Concepts and Technology of Flexible Ac Transmission Systems", Standard Publishers Distributors, IEEE Press, New York, 2001.
- [8] "Thyristorised Real Time Power Factor Correction (TRTPFC)", Sanjay N. Patel, International Journal of Engineering Research & Technology (IJERT) Vol. 2 Issue 3, March – 2013, ISSN: 2278-0181
- [9] "An Innovative Transient Free Adaptive SVC in Stepless Mode of Control", U. Gudar and D. R. Patil, World Academy of Science, Engineering and Technology 53 2011.
- [10] "Power Factor Correction of Non-Linear Loads Employing a Single Phase Active Power Filter: Control Strategy, Design Methodology and Experimentation", Fabiana Pottker and Ivo Barbi, Federal University of Santa Catarina, Department of Electrical Engineering
- [11] "Power Factor Correction in Audio Applications, White paper, Extron.
- [12] "Op-Amps and Linear Integrated Circuits", Ramakant A. Gaykwad, Fourth Edition, Eastern Economy Edition.
- [13] Websites- 1. www.alldatasheets.com, 2. ieeexplore.com



10.22214/IJRASET



45.98



IMPACT FACTOR:
7.129



IMPACT FACTOR:
7.429



INTERNATIONAL JOURNAL FOR RESEARCH

IN APPLIED SCIENCE & ENGINEERING TECHNOLOGY

Call : 08813907089  (24*7 Support on Whatsapp)